

# Water Quality Management Plan (WQMP)

## Project Name:

Dana Point Harbor Revitalization - Commercial Core Area

Buildings 6 to 12 / Phase 4B

**WQ21-0033 GRD21-0090**

Prepared for:

**Dana Point Harbor Partners LLC  
610 Newport Center Drive, Suite 490  
Newport Beach, CA 92660  
949-723-7788**

Prepared by:

**Tait & Associates, Inc.**

**Engineer: Jacob Vandervis  
Registration No. RCE No. 46301  
701 N. Parkcenter Dr.  
Santa Ana, CA 92705  
714-560-8200**

**Engineer's Seal**

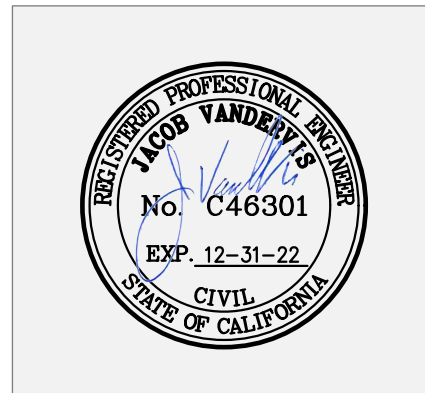

Building&Safety: jtyea  
Approval: Project Final WQMP  
Permits: GRD21-0090 WQ21-0033

10/26/2022



Prepared on:  
**5/20/2021**  
Revised on:  
**9/09/2022**

**Water Quality Management Plan (WQMP)**  
**Dana Point Harbor Revitalization- Commercial Core Area**

<b>Project Owner's Certification</b>			
Permit/ Application No.	CDP 13-0018	Grading Permit No.	GRD21-0090
Tract/Parcel Map No.	Parcel 7 & Portion of Parcels 6 & 5, Page 32-39	Building Permit No.	
CUP, SUP, and/or APN (Specify Lot Numbers if Portions of Tract)			

This Water Quality Management Plan (WQMP) has been prepared for Dana Point Harbor Partners LLC by Tait & Associates, Inc. . The WQMP is intended to comply with the requirements of the local NPDES Stormwater Program requiring the preparation of the plan.

The undersigned represents, the subject property owner (County of Orange) and is responsible for the implementation of the provisions of this plan and will ensure that this plan is amended as appropriate to reflect up-to-date conditions on the site consistent with the current Orange County Drainage Area Management Plan (DAMP) and the intent of the non-point source NPDES Permit for Waste Discharge Requirements for the County of Orange, Orange County Flood Control District and the incorporated Cities of Orange County within the San Diego Region (South Orange County). Once the undersigned transfers its interest in the property, its successors-in-interest shall bear the aforementioned responsibility to implement and amend the WQMP. An appropriate number of approved and signed copies of this document shall be available on the subject site in perpetuity.

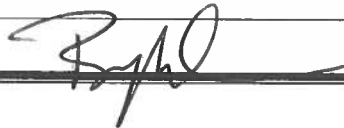
<b>Owner: Bryon Ward</b>	
Title	President
Company	Burnham-Ward Properties (Dana Point Harbor Partners, LLC Developer's Representative)
Address	1100 Newport Center Drive, Suite 200
Email	<a href="mailto:bward@burnham-ward.com">bward@burnham-ward.com</a>
Telephone #	(949) 760-9150
Signature	 11-9-27 <sup>Date</sup>

# Contents

Page No.

<b>Section 1</b>	<b>Discretionary Permit(s) and Water Quality Conditions .....</b>	<b>3</b>
<b>Section 2</b>	<b>Project Description .....</b>	<b>5</b>
<b>2.1</b>	<b>General Description .....</b>	<b>5</b>
<b>2.2</b>	<b>Post Development Drainage Characteristics .....</b>	<b>6</b>
<b>2.3</b>	<b>Property Ownership/Management .....</b>	<b>7</b>
<b>Section 3</b>	<b>Site &amp; Watershed Characterization .....</b>	<b>8</b>
<b>3.1</b>	<b>Site Conditions .....</b>	<b>8</b>
3.1.1	<i>Existing Site Conditions .....</i>	<i>8</i>
3.1.2	<i>Infiltration-Related Characteristics.....</i>	<i>10</i>
<b>3.2</b>	<b>Proposed Site Development Activities .....</b>	<b>12</b>
3.2.1	<i>Overview of Site Development Activities.....</i>	<i>12</i>
3.2.2	<i>Project Attributes Influencing Stormwater Management.....</i>	<i>12</i>
3.2.3	<i>Effects on Infiltration and Harvest and Use Feasibility .....</i>	<i>14</i>
<b>3.3</b>	<b>Receiving Waterbodies.....</b>	<b>14</b>
<b>3.4</b>	<b>Stormwater Pollutants or Conditions of Concern .....</b>	<b>15</b>
<b>3.5</b>	<b>Hydrologic Conditions of Concern.....</b>	<b>16</b>
<b>3.6</b>	<b>Critical Course Sediment Yield Areas .....</b>	<b>16</b>
<b>Section 4</b>	<b>Site Plan and Drainage Plan .....</b>	<b>17</b>
<b>4.1</b>	<b>Drainage Management Area Delineation .....</b>	<b>17</b>
<b>4.2</b>	<b>Overall Site Design BMPs .....</b>	<b>19</b>
<b>4.3</b>	<b>DMA Characteristics and Site Design BMPs .....</b>	<b>19</b>
4.3.5	<i>DMA Summary .....</i>	<i>20</i>
<b>4.4</b>	<b>Source Control BMPs .....</b>	<b>21</b>
<b>Section 5</b>	<b>Low Impact Development BMPs .....</b>	<b>28</b>
<b>5.1</b>	<b>LID BMPs in DMA C .....</b>	<b>28</b>
5.1.1	<i>Hydrologic Source Controls for DMA C.....</i>	<i>28</i>
5.1.2	<i>Structural LID BMP for DMA C.....</i>	<i>28</i>
<b>5.2</b>	<b>LID BMPs in DMA D .....</b>	<b>28</b>
5.2.1	<i>Hydrologic Source Controls for DMA D.....</i>	<i>28</i>
5.2.2	<i>Structural LID BMP for DMA D.....</i>	<i>28</i>
<b>5.3</b>	<b>LID BMPs in DMA E .....</b>	<b>28</b>
5.3.1	<i>Hydrologic Source Controls for DMA E .....</i>	<i>29</i>
5.3.2	<i>Structural LID BMP for DMA E.....</i>	<i>29</i>
<b>Section 6</b>	<b>Hydromodification BMPs.....</b>	<b>30</b>
<b>6.1</b>	<b>Points of Compliance .....</b>	<b>30</b>
<b>6.2</b>	<b>Pre-Development (Natural) Conditions .....</b>	<b>30</b>
<b>6.3</b>	<b>Post-Development Conditions and Hydromodification BMPs .....</b>	<b>30</b>
<b>6.4</b>	<b>Measures for Avoidance of Critical Coarse Sediment Yield Areas.....</b>	<b>30</b>
<b>6.5</b>	<b>Hydrologic Modeling and Hydromodification Compliance.....</b>	<b>30</b>

**Section 7 Educational Materials Index ..... 31**

**Attachment A: Educational Materials ..... 35**

**Attachment B: Operations and Maintenance Plan ..... 163**

**Attachment C: Site Plans ..... 247**

**Attachment D: Orange County Tech. Guidance Doc. Maps ..... 254**

**Attachment E: Calculations and Worksheets..... 266**

**Attachment F: Proprietary BMP Information ..... 276**

**Attachment G: Geotechnical Information ..... 352**

# Section 1 Discretionary Permit(s) and Water Quality Conditions

<b>Project Information</b>			
Permit/ Application No.	CDP 13-0018(I) City Resolution 14-11-18-06 GRD21-0090	Site Address or Tract/Parcel Map No.	Parcel 10 & Portion of Parcel 2, Page 32-39
Additional Information/ Comments:	<p>The project described of this report is of a larger development that consist of the Revitalization of Dana Point Harbor (DPH), in 2006 the Environmental Impact Report (EIR) was approved, in November 18, 2014 the CDP was approved by the Coastal Commission and the City of Dana Point, in May 29, 2019 the Substantial Conformance to the 2014 CDP. The project includes the improvements of the Commercial Core Area (CCA) will be completed in separate phases. The scope of work for the project described on this report consist of the parking structure area and Golden Lantern Street.</p> <p>The improvements include the construction of seven new two story buildings (located along the waterfront of the East Cove Marina), multiple paved surface parking lots and newly landscaped areas.</p> <p>A Master Drainage Plan that includes water quality BMP's, for the rough grading improvements has been prepared under Permit MB19-0039 &amp; Rough Grading (GRD19-0177)</p> <p>Site location and overall site plan exhibits for the project are included on attachment C.</p>		
<b>Water Quality Conditions</b>			

<p>Water Quality Conditions from prior approvals or applicable watershed-based plans</p>	<p><b>[ WQ01 ] WATER QUALITY MANAGEMENT PLAN</b></p> <p>Prior to the issuance of any grading or building permits, the applicant shall submit for review and approval by the Manager, Permit Services, a Water Quality Management Plan (WQMP) specifically identifying Best Management Practices (BMPs) that will be used onsite to control predictable pollutant runoff. The applicant shall utilize the Orange County Drainage Area Management Plan (DAMP), Model WQMP, and Technical Guidance Manual for reference, and the County’s WQMP template for submittal. This WQMP shall include the following:</p> <ul style="list-style-type: none"><li>- Detailed site and project description</li><li>- Potential stormwater pollutants</li><li>- Post-development drainage characteristics</li><li>- Low Impact Development (LID) BMP selection and analysis</li><li>- Structural and Non-Structural source control BMPs</li><li>- Site design and drainage plan (BMP Exhibit)</li><li>- GIS coordinates for all LID and Treatment Control BMPs</li><li>- Operation and Maintenance (O&amp;M) Plan that (1) describes the long-term operation and maintenance requirements for BMPs identified in the BMP Exhibit; (2) identifies the entity that will be responsible for long-term operation and maintenance of the referenced BMPs; and (3) describes the mechanism for funding the long-term operation and maintenance of the referenced BMPs</li></ul> <p>The BMP Exhibit from the approved WQMP shall be included as a sheet in all plan sets submitted for plan check and all BMPs shall be depicted on these plans. Grading and building plans must be consistent with the approved BMP exhibit.</p> <p>A summary of the Water Quality Conditions of Approval for Dana Point Harbor per the CDP are included in Appendix H.</p>
--	--

## **Section 2 Project Description**

### **2.1 General Description**

<b>Description of Proposed Project</b>				
Site Location	34501-34601 Dana Point Harbor, See Site Plans in Attachment C.			
Project Area (ft <sup>2</sup> ):537,095 ft <sup>2</sup>	Number of Dwelling Units: 0		SIC Code: 0919, 4493	
Narrative Project Description:	<p>This Project is comprised of the Commercial Core Area which covers approx. 12.33 acres within the 277-acre Dana Point Harbor.</p> <p><u>Commercial Core Area</u></p> <p>Commercial Core Area consists of 7 new two story buildings with retail, restaurants, office shell tenant space buildings with an ocean front boardwalk (located along the waterfront of the East Cove Marina). The new buildings are separated by landscape and hardscape walkways and some consist of a 2<sup>nd</sup> level deck. The proposed improvements also include multiple paved surface parking lots, and newly landscaped areas.</p> <p>The building have been numbered from 6 to 12 and range in size from 7,258 sf to 9,905 sf.</p>			
Project Area	Pervious		Impervious	
	Area (acres or sq ft)	Percentage	Area (acres or sq ft)	Percentage
Pre-Project Conditions	1.23ac	10%	11.10 ac	90%
Post-Project Conditions	1.28ac	10.4%	11.05ac	89.6%

## **2.2 Post Development Drainage Characteristics**

### Commercial Core Area

The project has been broken down into 3 major drainage areas discharging to one of three outfalls:

- Drainage area 1 consists of sub-areas C1.1 to C1.3 with a total acreage of 1.06 ac. Stormwater sheet flows from the parking lot to one of three Modular Wetlands Treatment Units. These Areas also have grated inlets with a highflow bypass in excess of the treatment flow rate. Low flows are diverted to the Modular Wetlands Units via a Dvert System. Stormwater is then conveyed to and underground storm drain system (Storm Drain Lateral C1). Stormwater then flows east to the backbone storm drain system ultimately discharging to Outfall 3.
- Drainage area 2 consists of sub-areas C3.2 to C3.9 with a total acreage of 3.34 ac. Stormwater sheet flows from the parking lot to one of six Modular Wetlands Treatment Units. These Areas also have grated inlets with a highflow bypass in excess of the treatment flow rate. Low flows are diverted to the Modular Wetlands Units via a Dvert System. Area C3.5 has an internal bypass system to divert high flow directly to the stormdrain system. Stormwater is then conveyed to and underground storm drain system (Storm Drain Lateral C3). Stormwater then flows east to the backbone storm drain system ultimately discharging to Outfall 3.
- Drainage area 3 consists of sub-areas C4.1 and C4.2 with a total acreage of 1.32 ac. Stormwater flows from portions Building 9 to ground level via down drains to the parking lot then sheet flows to one of two Modular Wetlands Treatment Units. These Areas also have grated inlets with a highflow bypass in excess of the treatment flow rate. Low flows are diverted to the Modular Wetlands Units via a Dvert System. Stormwater is then conveyed to and underground storm drain system (Storm Drain Lateral C4). Stormwater then flows east to the backbone storm drain system ultimately discharging to Outfall 3.
- Drainage area 4 consists of one sub-areas C-5 with a total acreage of 0.69 ac. Stormwater flows from portions Buildings 9 & 11 and all of Building 10 to ground level via down drains. Stormwater then flow to area drains and then to the underground storm drain system and treated via a StormVault with StormSafe cartridges. Stormwater then flows east to the backbone storm drain system ultimately discharging to Outfall 3.
- Drainage area 5 consists of one sub-areas C-6 with a total acreage of 0.94 ac. Stormwater flows from Building 8 to ground level via down drains. Stormwater then flow to area drains and then to the underground storm drain system and treated via a StormVault with StormSafe cartridges. Stormwater then flows west to the backbone storm drain system ultimately discharging to Outfall 3.
- Drainage area 6 consists of one sub-areas D-1 with a total acreage of 3.00 ac. Stormwater flows from portions of Buildings 6 and 7 to ground level via down drains. Stormwater then flow to area drains and then to the underground storm drain system (Storm Drain Lateral D) and treated via a StormVault with StormSafe cartridges. The StormVault system as been sized to also treat future improvement along the east side of D-1. Stormwater then flows southwest to storm drain system ultimately discharging to Outfall 4.
- Drainage area 7 consists of sub-areas E.1 to E.7 with a total acreage of 1.98 ac. Stormwater sheet flows from the parking lot and the eastern half Casitas Place drive isle to one of three Modular Wetlands Treatment Units for areas E.1 to E.5 along with Building 12. Areas E.1

E.2, E.3, and E.4 areas also have grated inlets with a highflow bypass in excess of the treatment flow rate. Low flows are diverted to the Modular Wetlands Units via a Dvert System. Stormwater is then conveyed to an underground storm drain system (Storm Drain Lateral E). Stormwater then flows south to area E.5. Stormwater from a portion of Building 11 discharges to ground level via down drains to area drains. Area E.5 has an internal bypass system to divert high flow directly to the storm drain system. Stormwater is then conveyed from Lateral E. Areas E.6 & E.7 have area drains that are connected to one of two StormVaults with StormSafe cartridges. These two are connected to Lateral E and then discharged to outfall 5.

Outfalls 3, 4 and 5 are piped to the ocean through existing storm drain outlets. Portion of the existing boardwalk in the Dana Wharf will sheet flow directly to the marina/harbor.

See Storm Drain plans and WQMP Plans for the locations, elevations, BMP numbers, locations and sizes and Outfalls in Attachment C.

## **2.3 Property Ownership/Management**

### **Ownership of all portions of the site:**

Dana Point Harbor Partners LLC will be responsible for the areas based on an existing 66-year lease agreement with the County of Orange.

- A property owners association or homeowners association will not be formed for this project.
- No infrastructure will be transferred to public agency.

### **Long Term Maintenance:**

The Dana Point Harbor Partners LLC will provide long term maintenance of all BMP's for this project.

## **Section 3 Site & Watershed Characterization**

### **3.1 Site Conditions**

#### **3.1.1 Existing Site Conditions**

##### Commercial Core Area

- The site is currently developed consist mainly of commercial areas, which includes Retail shops, Restaurants, and paved parking lots. There are no upstream areas directly draining onto the site (the existing upstream drainage area is fully captured by an existing storm drain line). There are no environmentally sensitive areas on the site.
- Slopes from north to south at approx. an average of 2.5%.
- The park at the northern property line ranges from 20' to 17' in elevation. The parking lot and southern building and landscape ranges from 13.5' to 9.7' in elevation.
- The existing boardwalk, landscape area, and building next to the dock drains directly to the marina/harbor. The parking lot drains from north to south via sheet flow to the curb face along the southern parking lot. Stormwater then drain to catch basins with filter insert and trash guards.
- The existing land use is park, parking and commercial buildings and restaurants.

<b>Existing Land Uses</b>				
Land Use Description	Total Area (acres)	Impervious Area (acres)	Pervious Area (acres)	Imperviousness (%)
<b>Commercial Core Area</b> (Park, Parking, and Commercial Buildings) <i>Land use 1</i>	12.33ac	11.10 ac	1.23ac	90%

### **3.1.2 Infiltration-Related Characteristics**

The project does not propose the use of an infiltration system. The project areas are located directly next to the marina/harbor. The groundwater is approx. 5' to 15' below ground surface elevation around the site. The historical high groundwater around the site is approx. 5' below ground surface elevation. Pollutants would migrate directly into the groundwater, since not enough soil lies between the bottom of an infiltration system and the groundwater table. In addition, groundwater elevations across the site are controlled by the elevation of the water within the adjacent harbor but are also somewhat influenced by the pre-development topography, with lower elevations found closest to the seawall. Groundwater elevations measured during the exploration were affected by the time of day as it relates to the local tidal cycle, and therefore should be assumed to fluctuate with the tides, the lunar cycle, and recent rainfall events. See **Attachment G** for geotechnical information.

#### **3.1.2.1 Hydrogeologic Conditions**

The groundwater is approx. 5' to 15' below ground surface elevation around the site. The historical high groundwater around the site is approx. 5' below ground surface elevation. In addition, groundwater elevations across the site are controlled by the elevation of the water within the adjacent harbor but are also somewhat influenced by the pre-development topography, with lower elevations found closest to the seawall. Groundwater elevations measured during the exploration were affected by the time of day as it relates to the local tidal cycle, and therefore should be assumed to fluctuate with the tides, the lunar cycle, and recent rainfall events. See **Attachment G** for geotechnical information.

#### **3.1.2.2 Soil and Geologic Infiltration Characteristics**

### **SITE INFILTRATION**

Several isolated percolation test results from the previous investigation and the current test at DH-17 do indicate the possibility for infiltration. However, because of the high variability of the surficial soils, isolated “passing” results are not considered representative (i.e., a “non-passing” result could be found a few feet away).

Thus, we conclude for the entire site that infiltration rates do not meet the minimum requirement of 0.3 inch/hour when a factor of safety of 2 is implemented per the County of Orange TGD manual. Consequently, options include “contain and treat systems”, permeable pavers, and bio-swales with collection systems, etc.

#### **3.1.2.3 Geotechnical Conditions**

##### Artificial Fill (Qaf)

The artificial fill materials within the site originated from both the marine deposits and bedrock within the cove and from the talus deposits and bedrock materials along the base of the sea cliffs. As

a result of the fill materials being derived from a variety of different geologic units, the fill materials are highly variable and consist of frequently alternating layers of clayey sands, silty sands, sands, sandy clays, and sandy silts. In general, the granular sand materials were found to be medium dense to dense while the fine-grained clay and silt materials were found to be predominantly firm to very firm. In addition, our laboratory testing indicates that the fill materials have varying amounts of compressibility and hydro-collapse.

### Marine Deposits (Qm)

The Marine deposit materials within the site are composed of materials deposited in beach and submarine environments, and where encountered, generally consist of wet, loose to medium dense, silty sands to sands and sandy clay.

### Capistrano Formation (Tc)

Capistrano Formation bedrock was encountered below the fill and/or marine deposits in all of our deeper drill holes and in all of our CPT soundings. The bedrock was observed to consist predominantly of hard to very hard, fine- to coarse-grained, massive sandstones with occasional beds of moderately hard to hard, gray to very dark gray claystones and siltstones.

Based on the results of past and most recent subsurface explorations, the subject Commercial Component site is summarized as follows:

- **Commercial Buildings:** The planned retail/restaurant, museum, and observation tower buildings are underlain by approximately 12.5 to 15 feet of artificial fill, terrace deposits in places, and then by bedrock materials of the Capistrano Formation.
- **3-Level Parking Structure:** The planned 3-Level Parking Structure adjacent to Street of the Golden Lantern and Dana Point Harbor Drive is underlain by approximately 12.5 to 15 feet of artificial fill, terrace deposits in places, and then by bedrock materials of the Capistrano Formation.

#### **3.1.2.4 Summary of Infiltration Opportunities and Constraints of Existing Site**

Infiltration is not an option for this project. The groundwater table for the area is within 15' of the existing ground elevation. In addition, the percolation testing resulted in a rate less than the required per the TGD.

## **3.2 Proposed Site Development Activities**

### **Commercial Core Area**

- Land Uses: Parks, Parking, and Commercial Buildings.
- Topography: Ranges from 20' to 17' in elevation.
- Drainage Features: Area drains for the landscape areas between the buildings. Modular Wetland Units for the parking lot areas. The landscape area drains will tie into the Modular Wetlands Units for stormwater treatment.
- Landscape Areas: North of the parking lot is a small park. Landscape islands throughout the parking lot. Landscape/turf areas between the buildings.
- Site Activities: Park Activities, Automobile Parking, Lounge Area within Buildings, Retail, Restaurant and Office Shell Tenant Space.

#### **3.2.1 Overview of Site Development Activities**

The overall type of development proposed are Lounge Area within Buildings, Retail, Restaurants, Office Shell Tenant Space, parking lots and landscaped areas. The overall characteristics of the site will not change from the existing. The interface between the adjacent parcels/properties will remain the same.

#### **3.2.2 Project Attributes Influencing Stormwater Management**

Potential Pollutant Generating Activities:

- SICs: 0919 & 4493
- Materials and Product: Boat supplies and equipment.
- Waste Generated: Waste associated with marine use (general trash and debris, fish cleaning waste, activities associated with fishing wastes, etc.).
- There are a total 7 building onsite and will be used for restrooms, showers, reception areas, boater storage facilities, offices, kitchens, conference rooms, and lounge areas.
- The landscape areas are shown on the projects sites plans and WQMP Plot Plans.
- This project does not have slopes of significance.
- The project does not consist of run-on to the site.
- Run-off from the site will consist of boardwalks adjacent to the marine draining to the ocean. All other stormwater will be directed to grated inlet or catch basin and then be piped to the headwall adjacent to the marina/ocean.
- The project does not have any environmentally sensitive features to be preserved.

<b>Proposed Land Uses</b>				
Land Use Description	Total Area (acres)	Impervious Area (acres)	Pervious Area (acres)	Imperviousness (%)
<u>Commercial Core Area</u> (Parks, Parking, and Commercial/Restaurant Buildings)	12.33	11.05	1.28	89.6

### **3.2.3 Effects on Infiltration and Harvest and Use Feasibility**

This project does not propose the use of Infiltration or Harvest and Reuse BMPs. The groundwater elevation is too shallow for infiltration. In addition, the percolation rate is below the acceptable rates for infiltration. This project does not contain enough landscape for Harvest and Reuse BMPs. In addition, this project will utilize reclaimed water in lieu of Harvest and Reuse.

### **3.3 Receiving Waterbodies**

The project does not discharge to an environmentally sensitive area.

The project discharges to Dana Point Harbor that is listed for water quality impairment on the most recent 303(d)-list for:

- Copper
- Toxicity
- Zinc
- Indicator Bacteria
- Oxygen dissolved

### 3.4 Stormwater Pollutants or Conditions of Concern

<b>Pollutants or Conditions of Concern</b>				
<b>Pollutant</b>	<b>Expected from Proposed Land Uses/ Activities (Yes or No)</b>	<b>Receiving Waterbody Impaired (Yes or No)</b>	<b>Priority Pollutant from WQIP or other Water Quality Condition? (Yes or No)</b>	<b>Pollutant of Concern (Primary, Other, or No)</b>
Suspended-Solids	x	No	No	No
Nutrients	x	No	No	No
Heavy Metals	x	Yes	Yes	Primary
Bacteria/Virus/Pathogens	x	Yes	Yes	Primary
Pesticides	x	No	No	No
Oil and Grease	x	No	No	No
Toxic Organic Compounds	x	Yes	Yes	Primary
Trash and Debris	x	No	No	No
Dry Weather Runoff	x	No	Yes	No

### **3.5 Hydrologic Conditions of Concern**

Does a hydrologic condition of concern exist for this project? No, the project drains directly the Dana Point Harbor and the Pacific Ocean. The WQMP Plot Plan shows that the project site drains to Dana Point Harbor.

No - An HCOC does not exist for this receiving water because:

Project discharges directly to a protected conveyance (bed and bank are concrete lined the entire way from the point(s) of discharge to a receiving lake, reservoir, embayment, or the Ocean

Project discharges directly to storm drains which discharge directly to a reservoir, lake, embayment, ocean or protected conveyance (as described above)

The project discharges to an area identified in the WMAA as exempt from hydromodification concerns

Yes - An HCOC does exist for this receiving water because none of the above are applicable.

Repeat this checklist for each different receiving water to which the project would discharge.

### **3.6 Critical Course Sediment Yield Areas**

Not Applicable

## Section 4 Site Plan and Drainage Plan

### 4.1 Drainage Management Area Delineation

#### Commercial Core Area

The project has been broken down into 7 major drainage areas discharging to one of three outfalls:

- Drainage area 1 consists of sub-areas C1.1 to C1.3 with a total acreage of 1.06 ac consisting of the northeast portion of the parking lot with landscape islands. Stormwater sheet flows from the parking lot to one of three Modular Wetlands Treatment Units. These Areas also have grated inlets with a highflow bypass in excess of the treatment flow rate. Low flows are diverted to the Modular Wetlands Units via a Dvert System. Stormwater is then conveyed to and underground storm drain system (Storm Drain Lateral C1). Stormwater then flows east to the backbone storm drain system ultimately discharging to Outfall 3.
- Drainage area 2 consists of sub-areas C3.2 to C3.9 with a total acreage of 3.34 ac consisting of a majority of the parking lot with landscape islands and sidewalk. Stormwater sheet flows from the parking lot to one of six Modular Wetlands Treatment Units. These Areas also have grated inlets with a highflow bypass in excess of the treatment flow rate. Low flows are diverted to the Modular Wetlands Units via a Dvert System. Area C3.5 has an internal bypass system to divert high flow directly to the stormdrain system. Stormwater is then conveyed to and underground storm drain system (Storm Drain Lateral C3). Stormwater then flows east to the backbone storm drain system ultimately discharging to Outfall 3.
- Drainage area 3 consists of sub-areas C4.1 and C4.2 with a total acreage of 1.54 ac consisting of the southwest parking lot, landscaped areas, sidewalk and roofs including overdrains and second floor decks. Stormwater flows from portions of Buildings 11, 10, 9 and 8 to ground level via overdrains then surface flows to the parking lot and ultimately to one of two Modular Wetlands Treatment Units. These Areas also have grated inlets with a highflow bypass in excess of the treatment flow rate. Low flows are diverted to the Modular Wetlands Units via a Dvert System. Stormwater is then conveyed to and underground storm drain system (Storm Drain Lateral C4). Stormwater then flows east to the backbone storm drain system ultimately discharging to Outfall 3.
- Drainage area 4 consists of one sub-areas C-5 with a total acreage of 0.78 ac consisting of sidewalk, landscaped areas and roofs including overdrains and second floor decks. Stormwater flows from portions of Buildings 9 & 10 either to ground level via down drains or overdrains connected to the storm drain system. Stormwater then flow to area drains and then to the underground storm drain system and treated via a StormVault with StormSafe cartridges. Stormwater then flows east to the backbone storm drain system ultimately discharging to Outfall 3.
- Drainage area 5 consists of one sub-areas C-6 with a total acreage of 0.58 ac consisting of sidewalk, landscaped areas and roofs including overdrains and second floor decks. Stormwater flows from Building 8 to overdrains connected to the storm drain system. Surface stormwater flows to area drains and then to the underground storm drain system and treated via a StormVault with StormSafe cartridges. Stormwater then flows west to the backbone storm drain system ultimately discharging to Outfall 3.
- Drainage area 6 consists of one sub-area D-1 with a total acreage of 3.05 ac consisting of sidewalk, landscaped areas, roofs including overdrains and second floor decks, and future

improvements along the east/southeast side of D-1 (that includes buildings, a small parking lot, drive aisles, landscaping, sidewalk, etc). Stormwater flows from portions of Buildings 6 and 7 to overdrains connected to the storm drain system. Surface stormwater flows to area drains and then to the underground storm drain system (Storm Drain Lateral D) and treated via a StormVault with StormSafe cartridges. The StormVault system has been sized to also treat the abovementioned future improvements. Stormwater then flows southwest to storm drain system ultimately discharging to Outfall 4.

- Drainage area 7 consists of sub-areas E.1 to E.7 with a total acreage of 1.98 ac consisting of the southwest portion of the parking lot, the eastern half of Casitas Place, landscape areas, sidewalk, and roofs/decks of Building 11 and 12. Stormwater sheet flows from the parking lot and the eastern half Casitas Place drive isle to one of three Modular Wetlands Treatment Units for areas E.1 to E.5 along with Building 12. Areas E.1, E.2, E.3, and E.4 areas also have grated inlets with a highflow bypass in excess of the treatment flow rate. Low flows are diverted to the Modular Wetlands Units via a Dvert System. Stormwater is then conveyed to and underground storm drain system (Storm Drain Lateral E). Stormwater then flows south to area E.5. Stormwater from portions of Building 11 and 12 discharge to ground level via roof drains and surface flows to adjacent area. Area E.5 has an internal bypass system to divert high flow directly to the storm drain system. Stormwater is then conveyed from Lateral E. Areas E.6 & E.7 have area drains that are connected to one of two StormVault with StormSafe cartridges. These two are connected to Lateral E and then discharged to outfall 5. This DMA also includes the event lawn south of Building 11 which is designed as synthetic turf and the westerly side of Building 12 where there will be synthetic turf landscape area serving as a fire lane and an area for kayak and paddle board rentals. In addition, the southerly portions include the pedestrian boardwalk along the seawall and a treated timber boardwalk, that drains below to a storm drain collector which then takes the water to StormSafe units. These units will provide treatment for possible leached metals from the boardwalk.

Outfalls 3, 4 and 5 are piped to the ocean through existing storm drain outlets. Portion of the existing boardwalk in the Dana Wharf will sheet flow directly to the marina/harbor.

See Storm Drain plans and WQMP Plans for the locations, elevations, BMP numbers, locations, sizes and Outfalls in Attachment C.

## **4.2 Overall Site Design BMPs**

**Minimize Impervious Area-** The project will utilize the minimum safe widths in drive isles, parking stalls, and sidewalks, thereby maximizing the landscape area and minimizing the impervious areas.

**Maximize Natural Infiltration Capacity-** This project consists of minimal landscape and infiltration is not being maximize as the project is located directly adjacent to Dana Point Harbor.

**Preserve Existing Drainage Patterns and Time of Concentration-** The site has been designed to closely mimick the existing drainage pattern and the times of concentration will not change.

**Disconnect Impervious Areas -** This project consists of mostly parking areas, however for three areas landscaping has been placed between the building thereby disconnecting the impervious buildings.

**Protect Existing Vegetation and Sensitive Areas -** All four areas are being completely demolished and rebuilt. Protecting existing vegetation is not feasible within the areas of construction.. This project does not contain sensitive areas.

**Revegetate Disturbed Areas -** To the maximum extent practicable, disturbed areas will be re-vegetated.

**Soil Stockpiling and Site Generated Organics -** Not Applicable

**Firescaping -** No Applicable

**Water Efficient Landscaping -** This project will incorporate water efficient landscaping for the minimal landscape around the project.

**Slopes and Channel Buffers -** Not Applicable

### 4.3 DMA Characteristics and Site Design BMPs

#### 4.3.1 DMA Summary

<b>Drainage Management Areas</b>				
DMA (Number/Description)	Total Area (acres)	Imperviousness (%)	Infiltration Feasibility Category (Full, Partial, or No Infiltration)	Hydrologic Source Controls Used
DMA C1.1 to C-6 to Outfall 3  Parking Lot; Buildings 8 to 10; Portions of Buildings 11, 7 and 6; Landscaping; Sidewalk	7.30	92	No Infiltration	None
DMA D-1 to Outfall 4  Portions of Buildings 6 and 7; Landscaping; Sidewalk; Future Improvements (including buildings, a small parking lot, drive aisles, landscaping, sidewalk)	3.05	90	No Infiltration	None
DMA E-1 to E-7 to Outfall 5  Eastern Half of Casitas Place; Parking Lot; Building 12; Portion of Building 11; Landscaping (including turf for fire lane and rental equipment) Sidewalk	1.98	85	No Infiltration	None

## 4.4 Source Control BMPs

<b>Non-Structural Source Control BMPs</b>				
Identifier	Name	Check One		Reason Source Control is Not Applicable
		Included	Not Applicable	
N1	Education for Property Owners, Tenants and Occupants	<input checked="" type="checkbox"/>	<input type="checkbox"/>	
N2	Activity Restrictions	<input checked="" type="checkbox"/>	<input type="checkbox"/>	
N3	Common Area Landscape Management	<input checked="" type="checkbox"/>	<input type="checkbox"/>	
N4	BMP Maintenance	<input checked="" type="checkbox"/>	<input type="checkbox"/>	
N5	Title 22 CCR Compliance (How development will comply)	<input checked="" type="checkbox"/>	<input type="checkbox"/>	
N6	Local Industrial Permit Compliance	<input type="checkbox"/>	<input checked="" type="checkbox"/>	This is not an Industrial Project.
N7	Spill Contingency Plan	<input checked="" type="checkbox"/>	<input type="checkbox"/>	
N8	Underground Storage Tank Compliance	<input type="checkbox"/>	<input checked="" type="checkbox"/>	This project does not contain underground storage tanks.
N9	Hazardous Materials Disclosure Compliance	<input checked="" type="checkbox"/>	<input type="checkbox"/>	
N10	Uniform Fire Code Implementation	<input checked="" type="checkbox"/>	<input type="checkbox"/>	
N11	Common Area Litter Control	<input checked="" type="checkbox"/>	<input type="checkbox"/>	
N12	Employee Training	<input checked="" type="checkbox"/>	<input type="checkbox"/>	
N13	Housekeeping of Loading Docks	<input type="checkbox"/>	<input checked="" type="checkbox"/>	This project does not contain loading docks.
N14	Common Area Catch Basin Inspection	<input checked="" type="checkbox"/>	<input type="checkbox"/>	
N15	Street Sweeping Private Streets and Parking Lots	<input checked="" type="checkbox"/>	<input type="checkbox"/>	
N16	Retail Gasoline Outlets	<input type="checkbox"/>	<input checked="" type="checkbox"/>	This project does not contain Retail Gasoline Outlets

***N1- Education for property Owners, Tenants and occupants & N-12 Employee Training***

The property owner shall prepare a training manuals for all existing and future employees. The manual shall include information regarding proper practices that contribute to the protection of the stormwater quality.

Training shall be provided upon hire of new associates. A copies of the training manuals shall remain in the building at all times for employees to use as needed. The manual shall include all Educational Material included on **Attachment A** of this report. Additional educational material may be found in the following website : <http://www.ocwatershed.com/PublicEd/resources/business-brochures.html>

***N2- Activity Restrictions***

The property owner shall ensure that the rules and guidelines as determined by the project conditions of approval or other policies are followed at all times once the project is operational. Prohibited activities for the project that promoted water quality includes:

Prohibit discharges of fertilizer, pesticides, or animal wastes to streets or storm drains.

Prohibit blowing or sweeping of debris (leaf litter, grass clippings, litter, etc.) into parking lots or storm drains.

Requirement to keep dumpster lids closed at all times.

Prohibit vehicle washing, maintenance, or repair on the premises or restrict those activities to designated areas.

***N3- Common Area Landscape Management***

Specific practices are followed for landscape maintenance as identified on the landscape specifications. Ongoing maintenance is conducted to minimize erosion and over-irrigation, conserve water and reduce pesticide and fertilizer applications.

All maintenance must be consistent with the City of Dana Point requirements. Proper maintenance practices should help reduce and/or eliminate pollution from pesticides, nutrients, trash/debris and sediments. The project common area landscape maintenance should be consistent with the following documents included in **Attachment A**:

- Tips for Landscape and Gardening
- Building and Ground Maintenance Guidelines
- Housekeeping practices
- Landscape maintenance

***N4- BMP Maintenance***

BMP maintenance, implementation schedules and responsible parties are included with each specific BMP.

***N5- Title 22 CCR compliance***

Hazardous waste shall be managed properly through compliance with applicable title 22 regulations.

Storage and transportation of hazardous materials shall be per the title 22of the California Code of Regulations and the Health and Safety Code.

***N7- Spill Contingency Plan***

The owner shall prepare a Spill Contingency Plan. The plan shall describe how the employees will prepare for and respond to spill of hazardous materials. The plan shall describe the stockpiling of cleanup materials, how to notify the responsible agencies, how to dispose of cleanup materials, the documentation of the spill of hazardous material events.

See **Attachment A** for additional information on plan preparation:

IC17 Spill Prevention and Cleanup

SC-11 Spill Prevention, Control and Cleanup

***N9- Hazardous Material Disclosure Compliance***

The owner is responsible for obtaining the required permits for the use and transportation of hazardous materials. Permits may be required from the County of Orange Health Department, City of Dana Point and other local authorities.

***N10- Uniform Fire Code Implementation***

The owner is responsible for complying with the Orange County Fire Department requirements regarding proper management of hazardous materials and emergency response plans. An inventory of hazardous materials shall be maintained on-site and an emergency response plans shall be established.

***N11-Common area litter control***

The Owner will be required to implement trash management and litter control procedures in the common areas aimed at reducing pollution of drainage water. The Owner may contract with their landscape maintenance firm to provide this service with regularly scheduled maintenance, which should consist of litter patrol, emptying of trash receptacles in common areas, and noting trash disposal violations and reporting the violations to the Owner for investigation.

See **Attachment A** for additional information:

IC3 Building Maintenance

FP-4 Sidewalk, Plaza, and Fountain Maintenance and Cleaning

SC-41 Building and Grounds Maintenance

SC-60 Housekeeping Practices

SC-71 Plaza and Sidewalk Cleaning

***N14-Common area catch basin inspection***

The Owner must ensure that the on-site drain inlets, grates, and drainpipes will be periodically inspected visually. Cleaning should take place in the late summer/early fall prior to the start of the rainy season. If necessary, clean, repair, or replace any drainage facility prior to the start of each rainy season (no later than October 15 of each year). Also, refer to “Drainage System Maintenance” and “Drainage Facility Operation and Maintenance” in **Attachment A**.

***N15-Street Sweeping Private Streets and Parking Lots***

The Owner must sweep outdoor lots regularly (minimum monthly) or as needed to maintain parking lot surface without trash, debris, or other removable solids, and prior to the storm season (no later than October 15 each year). Sweeping shall be done with a vacuum-type sweeper. Under no circumstances are outdoor areas/lots to be rinsed or washed with water unless said rinse/wash water is collected and disposed of properly (i.e. into the sewer).

See **Attachment A** for additional information:

IC15 Parking and Storage Area Maintenance

FF-9 Parking Lot Maintenance

SC-43 Parking/Storage Area Maintenance

<b>Structural Source Control BMPs</b>				
<b>Identifier</b>	<b>Name</b>	<b>Check One</b>		<b>Reason Source Control is Not Applicable</b>
		<b>Included</b>	<b>Not Applicable</b>	
S1	Provide storm drain system stenciling and signage	<input checked="" type="checkbox"/>	<input type="checkbox"/>	
S2	Design and construct outdoor material storage areas to reduce pollution introduction	<input type="checkbox"/>	<input checked="" type="checkbox"/>	This project does not propose the outdoor storage of hazardous materials.
S3	Design and construct trash and waste storage areas to reduce pollution introduction	<input checked="" type="checkbox"/>	<input type="checkbox"/>	
S4	Use efficient irrigation systems & landscape design, water conservation, smart controllers, and source control	<input checked="" type="checkbox"/>	<input type="checkbox"/>	
S5	Protect slopes and channels and provide energy dissipation	<input type="checkbox"/>	<input checked="" type="checkbox"/>	This project does not contain slopes or channel of significance to require the use of energy dissipation devices.
	Incorporate requirements applicable to individual priority project categories (from SDRWQCB NPDES Permit)	<input type="checkbox"/>	<input checked="" type="checkbox"/>	Not Applicable to this project.
S6	Dock areas	<input type="checkbox"/>	<input checked="" type="checkbox"/>	This project does not contain dock areas.
S7	Maintenance bays	<input type="checkbox"/>	<input checked="" type="checkbox"/>	This project does not contain maintenance bays.
S8	Vehicle wash areas	<input type="checkbox"/>	<input checked="" type="checkbox"/>	This project does not contain vehicle wash areas.
S9	Outdoor processing areas	<input type="checkbox"/>	<input checked="" type="checkbox"/>	This project does not contain outdoor processing areas.
S10	Equipment wash areas	<input type="checkbox"/>	<input checked="" type="checkbox"/>	This project does not contain equipment wash areas.
S11	Fueling areas	<input type="checkbox"/>	<input checked="" type="checkbox"/>	This project does not contain fueling areas.
S12	Hillside landscaping	<input type="checkbox"/>	<input checked="" type="checkbox"/>	This project is not located on a hillside.
S13	Wash water control for food preparation areas	<input type="checkbox"/>	<input checked="" type="checkbox"/>	This project does not contain food preparation areas.
S14	Community car wash racks	<input type="checkbox"/>	<input checked="" type="checkbox"/>	This project does not contain community car wash racks.

***S1-Provide storm drain system stenciling and signage***

All catch basins/inlets/outlets on site must be marked using the City's "No Dumping - Drains to Ocean" curb marker or stenciled. An approved stencil shall be used to paint this message on the top of curb directly above the inlet, and on one side of the curb face. Labeling for catch basins is to be inspected regularly and maintained so as to be reasonably legible at all times. The inspection and maintenance is to be performed by the Owner. This stencil is to alert the public/employees to the destination of pollutants discharged into the storm water.

See CASQA Stormwater Handbook BMP Fact Sheet SD-13 ([Attachment A](#)) for additional information.

***S3-Design and construct trash and waste storage areas to reduce pollution introduction***

The owner shall post signs on trash enclosure gates that state "Keep Dumpster Lids Closed." The Owner will monitor dumpster usage such that dumpsters are not overfilled and the dumpster lids can close completely. The Owner shall increase the trash pickup schedule as necessary to prevent dumpsters from overflowing. The Owner will observe and damage to the trash enclosure wall and any discharge from the trash storage area.

Trash storage areas shall be designed to reduce pollutant introduction. All trash container areas shall meet the following requirements:

1. Paved with an impervious surface, designed not to allow run-on from adjoining areas, designed to divert drainage from adjoining roofs and pavements diverted around the area, screened or walled to prevent off-site transport of trash; and
2. Provide solid roof or awning to prevent direct precipitation.

Connection of trash area drains to the municipal storm drain system is prohibited.

Potential conflicts with fire code and garbage hauling activities should be considered in implementing this source control.

See CASQA Stormwater Handbook Section 3.2.9 and BMP Fact Sheet SD-32 ([Attachment A](#)) for additional information.

***S4-Use efficient irrigation systems & landscape design, water conservation, smart controllers, and source control***

All irrigation systems will be inspected to ensure that the systems are functioning properly and that the programmable timers are set correctly.

Timing and application methods of irrigation water shall be designed to minimize the runoff of excess irrigation water into the municipal storm drain system. The following methods to reduce excessive irrigation runoff shall be incorporated in common areas of development:

1. Employing rain shutoff devices to prevent irrigation after precipitation.
2. Designing irrigation systems to each landscape area's specific water requirements.
3. Using flow reducers or shutoff valves triggered by a pressure drop to control water loss in the event of broken sprinkler heads or lines.

4. Implementing landscape plan consistent with County Water Conservation Resolution or city equivalent, which may include provision of water sensors, programmable irrigation times (for short cycle), etc.
5. The timing and application methods of irrigation water shall be designed to minimize the runoff of excess irrigation water into the municipal storm drain system.
6. Employing other comparable, equally effective, methods to reduce irrigation water runoff.
7. Group plants with similar water requirements in order to reduce excess irrigation runoff and promote surface filtration. Choose plants with low irrigation requirements (for example, native or drought tolerant species). Consider other design features, such as:
  - Use mulches (such as wood chips or shredded wood products) in planter areas without ground cover to minimize sediment in runoff.
  - Install appropriate plant materials for the location, in accordance with amount of sunlight and climate, and use native plant material where possible and/or as recommended by the landscape architect.
  - Leave a vegetative barrier along the property boundary and interior watercourse, to act as a pollutant filter, where appropriate and feasible.
  - Choose plants that minimize or eliminate the use of fertilizer or pesticides to sustain growth.

Irrigation practices shall comply with local and statewide ordinances related to irrigation efficiency.

See CASQA Stormwater Handbook BMP Fact Sheet SD-12 ([Attachment A](#)) for additional information.

## **Section 5 Low Impact Development BMPs**

This project is not able utilized LID BMPs. This project does not propose the use of Infiltration or Harvest and Reuse BMPs. The groundwater elevation is too shallow for infiltration. In addition, the percolation rate are below the acceptable rates for infiltration. This project does not contain enough landscape for Harvest and Reuse BMPs. In addition, this project will utilize reclaimed water in lieu of Harvest and Reuse. This project will utilize Proprietary Biotreatment BMPs for the West Cove Area.

### **5.1 LID BMPs in DMA C**

Infiltration is not feasible for this project. Harvest and Use is not feasible for this project. This project will utilize Proprietary Biotreatment BMPs (Modular Wetland Units) for this DMA.

#### **5.1.1 Hydrologic Source Controls for DMA C**

Hydrologic Source Control are not proposed for this project. Where feasible, impervious area dispersion will be utilized.

#### **5.1.2 Structural LID BMP for DMA C**

This project will utilize Proprietary Biotreatment BMPs for this DMA.

### **5.2 LID BMPs in DMA D**

Infiltration is not feasible for this project. Harvest and Use is not feasible for this project. This DMA is too close to the ocean, LID BMP are not proposed for this DMA.

#### **5.2.1 Hydrologic Source Controls for DMA D**

Hydrologic Source Control are not proposed for this project. Where feasible, impervious area dispersion will be utilized.

#### **5.2.2 Structural LID BMP for DMA D**

This DMA will utilize StormVaults with StormSafe Cartidges.

### **5.3 LID BMPs in DMA E**

Infiltration is not feasible for this project. Harvest and Use is not feasible for this project. This project will utilize Proprietary Biotreatment BMPs (Modular Wetland Units) for this DMA.

### 5.3.1 Hydrologic Source Controls for DMA E

Hydrologic Source Control are not proposed for this project. Where feasible, impervious area dispersion will be utilized.

### 5.3.2 Structural LID BMP for DMA E

This project will utilize Proprietary Biotreatment BMPs and StormVaults with StormSafe Cartridges. for this DMA

Dana Point Harbor - Commercial Core Retail Area										
DMA Summary										
BMP No.	Area ID	Time of Concentration (min)	Design Intensity 80% capture efficiency (in/hr)	Area (ac)	Percent Impervious	Runoff Coefficient	Q80% (cfs)	Qdesign (cfs)	Q Treatment Capacity (cfs)	BMP Model
<b>OUTFALL 3</b>										
<b>STORM DRAIN LATERAL LINE C1</b>										
No. 1	C1.1	5.42	0.26	0.30	0.943	0.858	0.07	0.100	0.115	MWS-L-4-8-V (Dvert)
No. 2	C1.2	5.63	0.26	0.70	0.787	0.740	0.13	0.202	0.237	MWS-L-4-19-V (Dvert)
No. 3	C1.3	5.00	0.26	0.06	0.868	0.801	0.01	0.019	0.052	MWS-L-4-4-V (Dvert)
				<b>1.06</b>						
<b>STORM DRAIN LATERAL LINE C3</b>										
No. 4	C3.2	5.86	0.26	1.43	0.893	0.820	0.30	0.457	0.462	MWS-L-8-16-V (Dvert) HC=3.6
No. 5	C3.3	6.07	0.26	0.20	0.976	0.882	0.05	0.069	0.073	MWS-L-4-6-C
No. 6	C3.4	6.14	0.26	0.70	0.966	0.874	0.16	0.239	0.236	MWS-L-4-17-V (Dvert)
No. 7	C3.5	5.00	0.28	0.28	0.984	0.888	0.07	0.104	0.115	MWS-L-4-8-C
No. 8	C3.6	5.00	0.26	0.23	0.950	0.862	0.05	0.077	0.115	MWS-L-4-8-C
No. 9	C3.7	5.00	0.26	0.36	0.844	0.783	0.07	0.110	0.148	MWS-L-4-13-V (Dvert)
No. 9	C3.8	5.00	0.26	0.05	0.958	0.869	0.01	0.017		
No. 9	C3.9	5.00	0.26	0.07	0.898	0.824	0.01	0.022		
				<b>3.32</b>						
No. 14	C-5.1	5.37	0.26	0.81	0.833	0.775	0.16	0.245	0.768	StormSafe Filter (3 Pack)
No. 13	C-5.2	5.37	0.26	0.73	0.869	0.802	0.15	0.228	0.768	StormSafe Filter (3 Pack)
				<b>1.54</b>						
<b>STORM DRAIN LATERAL LINE C4</b>										
No. 10	C4.1	6.75	0.26	0.89	0.813	0.760	0.18	0.264	0.346	MWS-L-8-12-V (Dvert)
No. 11	C4.2	5.00	0.26	0.57	0.860	0.795	0.12	0.177	0.206	MWS-L-4-17-V (Dvert)
<b>OUTFALL 4</b>										
<b>STORM DRAIN LATERAL LINE E</b>										
No. 12	D-1	5.00	0.26	3.01	0.899	0.824	0.64	0.967	2.560	StormSafe Filter (10 Pack)
<b>OUTFALL 5</b>										
<b>STORM DRAIN LATERAL LINE D</b>										
No. 15	E-1	5.00	0.26	0.22	0.991	0.894	0.05	0.077	0.115	MWS-L-4-8-V (Dvert)
No. 16	E-2	5.00	0.26	0.27	0.837	0.778	0.05	0.082	0.147	MWS-L-6-8 ( internal bypass = 0.98 cfs)
No. 16	E-3	5.00	0.26	0.08	0.679	0.659	0.01	0.021		
No. 16	E-4	5.00	0.26	0.08	0.909	0.832	0.02	0.026		
No. 17	E-5	5.00	0.26	0.47	0.929	0.847	0.10	0.155	0.155	MWS-L-6-8 (Dvert)
No. 18	E-6	5.00	0.26	0.68	0.890	0.817	0.14	0.217	0.768	StormSafe Filter (3 Pack)
No. 19	E-7	5.00	0.26	0.21	0.832	0.774	0.04	0.063	0.256	StormSafe Filter (1 Pack)

## **Section 6 Hydromodification BMPs**

N.A.

### **6.1 Points of Compliance**

N.A.

### **6.2 Pre-Development (Natural) Conditions**

N.A.

### **6.3 Post-Development Conditions and Hydromodification BMPs**

N.A.

### **6.4 Measures for Avoidance of Critical Coarse Sediment Yield Areas**

N.A.

### **6.5 Hydrologic Modeling and Hydromodification Compliance**

N.A.

## Section 7 Educational Materials Index

<b>Educational Materials</b>			
<b>Residential Material</b> <b>(<a href="http://www.ocwatersheds.com">http://www.ocwatersheds.com</a>)</b>	<b>Check If</b> <b>Applicable</b>	<b>Business Material</b> <b>(<a href="http://www.ocwatersheds.com">http://www.ocwatersheds.com</a>)</b>	<b>Check If</b> <b>Applicable</b>
The Ocean Begins at Your Front Door	<input checked="" type="checkbox"/>	Tips for the Automotive Industry	<input type="checkbox"/>
Tips for Protecting Your Watershed	<input checked="" type="checkbox"/>		
Tips for Car Wash Fund-raisers	<input type="checkbox"/>	Tips for Using Concrete and Mortar	<input type="checkbox"/>
Tips for the Home Mechanic	<input type="checkbox"/>	Tips for the Food Service Industry	<input type="checkbox"/>
Homeowners Guide for Sustainable Water Use	<input type="checkbox"/>	Proper Maintenance Practices for Your Business	<input type="checkbox"/>
Household Tips	<input type="checkbox"/>	Compliance BMPs for Mobile Businesses	<input type="checkbox"/>
Proper Disposal of Household Hazardous Waste	<input type="checkbox"/>	<b>Other Material</b>	<b>Check If Attached</b>
Recycle at Your Local Used Oil Collection Center (North County)	<input type="checkbox"/>		
Recycle at Your Local Used Oil Collection Center (Central County)	<input type="checkbox"/>	DF-1 Drainage Facility Operation and Maintenance	<input checked="" type="checkbox"/>
Recycle at Your Local Used Oil Collection Center (South County)	<input checked="" type="checkbox"/>	FF-5 Landscape Maintenance	<input checked="" type="checkbox"/>
Tips for Maintaining a Septic Tank System	<input checked="" type="checkbox"/>	FF-7 Material Storage, Handling, and Disposal	<input checked="" type="checkbox"/>
Responsible Pest Control	<input type="checkbox"/>	FP-6 Water and Sewer Utility Operation and Maintenance	<input checked="" type="checkbox"/>
Sewer Spill	<input checked="" type="checkbox"/>	FF-9 Parking Lot Maintenance	<input checked="" type="checkbox"/>
Tips for the Home Improvement Projects	<input type="checkbox"/>	FF-10 Spill Prevention and Control	<input type="checkbox"/>
Tips for Horse Care	<input type="checkbox"/>	FP-4 Sidewalk, Plaza, and Fountain Maintenance and Cleaning	<input checked="" type="checkbox"/>
Tips for Landscaping and Gardening	<input type="checkbox"/>	FP-5 Solid Waste Handling	<input checked="" type="checkbox"/>
Tips for Pet Care	<input checked="" type="checkbox"/>		<input type="checkbox"/>
Tips for Projects Using Paint	<input type="checkbox"/>	SD-12 Efficient Irrigation	<input checked="" type="checkbox"/>
Orange County Use of Pest and Fert.	<input checked="" type="checkbox"/>	SD-13 Storm Drain Signage	<input checked="" type="checkbox"/>
SC-10 Non Storm Water Discharge	<input checked="" type="checkbox"/>	SD-32 Trash Storage Areas	<input checked="" type="checkbox"/>

# **Attachment A: Educational Materials**



Support from Orange County residents and businesses is needed to improve water quality and reduce urban runoff pollution. Proper use and disposal of materials will help stop pollution before it reaches the storm drain and the ocean.

Stormwater quality management programs have been developed throughout Orange County to educate and encourage the public to protect water quality, monitor runoff in the storm drain system, investigate illegal dumping and maintain storm drains.

Non-point source pollution can have a serious impact on water quality in Orange County. Pollutants from the storm drain system can harm marine life as well as coastal and wetland habitats. They can also degrade recreation areas such as beaches, harbors and bays.



### The Effect on the Ocean



- Automotive leaks and spills.
- Improper disposal of used oil and other engine fluids.
- Metals found in vehicle exhaust, weathered paint, rust, metal plating and tires.
- Pesticides and fertilizers from lawns, gardens and farms.
- Improper disposal of cleaners, paint and paint removers.
- Soil erosion and dust debris from landscape and construction activities.
- Litter, lawn clippings, animal waste, and other organic matter.
- Oil stains on parking lots and paved surfaces.

### Sources of Non-Point Source Pollution

- Anything we use outside homes, vehicles and businesses – like motor oil, paint, pesticides, fertilizers and cleaners – can be blown or washed into storm drains.
- A little water from a garden hose or rain can also send materials into storm drains.
- Storm drains are separate from our sanitary sewer systems; unlike water in sanitary sewers (from sinks or toilets), water in storm drains is not treated before entering our waterways.

### Where Does It Go?

- Most people believe that the largest source of water pollution in urban areas comes from specific sources such as factories and sewage treatment plants. In fact, the largest source of water pollution comes from city streets, neighborhoods, construction sites and parking lots. This type of pollution is sometimes called “non-point source” pollution.
- There are two types of non-point source pollution: stormwater and urban runoff.
- Stormwater runoff results from rainfall. When rainstorms cause large volumes of water to rinse the urban landscape, picking up pollutants along the way.
- Urban runoff can happen any time of the year when excessive water use from irrigation, vehicle washing and other sources carries trash, lawn clippings and other urban pollutants into storm drains.

### Did You Know?

Even if you live miles from the Pacific Ocean, you may be unknowingly polluting it.

Dumping one quart of motor oil into a storm drain can contaminate 250,000 gallons of water.

## For More Information

### California Environmental Protection Agency

[www.calepa.ca.gov](http://www.calepa.ca.gov)

- **Air Resources Board**  
[www.arb.ca.gov](http://www.arb.ca.gov)
- **Department of Pesticide Regulation**  
[www.cdpr.ca.gov](http://www.cdpr.ca.gov)
- **Department of Toxic Substances Control**  
[www.dtsc.ca.gov](http://www.dtsc.ca.gov)
- **Integrated Waste Management Board**  
[www.ciwmb.ca.gov](http://www.ciwmb.ca.gov)
- **Office of Environmental Health Hazard Assessment**  
[www.oehha.ca.gov](http://www.oehha.ca.gov)
- **State Water Resources Control Board**  
[www.waterboards.ca.gov](http://www.waterboards.ca.gov)

**Earth 911** - Community-Specific Environmental Information 1-800-cleanup or visit [www.1800cleanup.org](http://www.1800cleanup.org)

**Health Care Agency's Ocean and Bay Water Closure and Posting Hotline**  
(714) 433-6400 or visit [www.ocbeachinfo.com](http://www.ocbeachinfo.com)

**Integrated Waste Management Dept. of Orange County** (714) 834-6752 or visit [www.oclandfills.com](http://www.oclandfills.com) for information on household hazardous waste collection centers, recycling centers and solid waste collection

**O.C. Agriculture Commissioner**  
(714) 447-7100 or visit [www.ocagcomm.com](http://www.ocagcomm.com)

**Stormwater Best Management Practice Handbook**  
Visit [www.cabmphandbooks.com](http://www.cabmphandbooks.com)

**UC Master Gardener Hotline**  
(714) 708-1646 or visit [www.ucemg.com](http://www.ucemg.com)

The Orange County Stormwater Program has created and moderates an electronic mailing list to facilitate communications, take questions and exchange ideas among its users about issues and topics related to stormwater and urban runoff and the implementation of program elements. To join the list, please send an email to [ocstormwaterinfo-join@list.ocwatersheds.com](mailto:ocstormwaterinfo-join@list.ocwatersheds.com)

## Orange County Stormwater Program

Aliso Viejo . . . . .	(949)	425-2535
Anaheim Public Works Operations . . . . .	(714)	765-6860
Brea Engineering . . . . .	(714)	990-7666
Buena Park Public Works . . . . .	(714)	562-3655
Costa Mesa Public Services . . . . .	(714)	754-5323
Cypress Public Works . . . . .	(714)	229-6740
Dana Point Public Works . . . . .	(949)	248-3584
Fountain Valley Public Works . . . . .	(714)	593-4441
Fullerton Engineering Dept. . . . .	(714)	738-6853
Garden Grove Public Works . . . . .	(714)	741-5956
Huntington Beach Public Works . . . . .	(714)	536-5431
Irvine Public Works . . . . .	(949)	724-6315
La Habra Public Services . . . . .	(562)	905-9792
La Palma Public Works . . . . .	(714)	690-3310
Laguna Beach Water Quality . . . . .	(949)	497-0378
Laguna Hills Public Services . . . . .	(949)	707-2650
Laguna Niguel Public Works . . . . .	(949)	362-4337
Laguna Woods Public Works . . . . .	(949)	639-0500
Lake Forest Public Works . . . . .	(949)	461-3480
Los Alamitos Community Dev. . . . .	(562)	431-3538
Mission Viejo Public Works . . . . .	(949)	470-3056
Newport Beach, Code & Water Quality Enforcement . . . . .	(949)	644-3215
Orange Public Works . . . . .	(714)	532-6480
Placentia Public Works . . . . .	(714)	993-8245
Rancho Santa Margarita . . . . .	(949)	635-1800
San Clemente Environmental Programs . . . . .	(949)	361-6143
San Juan Capistrano Engineering . . . . .	(949)	234-4413
Santa Ana Public Works . . . . .	(714)	647-3380
Seal Beach Engineering . . . . .	(562)	431-2527 x317
Stanton Public Works . . . . .	(714)	379-9222 x204
Tustin Public Works/Engineering . . . . .	(714)	573-3150
Villa Park Engineering . . . . .	(714)	998-1500
Westminster Public Works/Engineering . . . . .	(714)	898-3311 x446
Yorba Linda Engineering . . . . .	(714)	961-7138
Orange County Stormwater Program . . . . .	(877)	897-7455
Orange County 24-Hour Water Pollution Problem Reporting Hotline 1-877-89-SPILL (1-877-897-7455)		

On-line Water Pollution Problem Reporting Form  
[www.ocwatersheds.com](http://www.ocwatersheds.com)

## The Ocean Begins at Your Front Door



# The Ocean Begins at Your Front Door



*Never allow pollutants to enter the street, gutter or storm drain!*

Follow these simple steps to help reduce water pollution:

## **Household Activities**

- Do not rinse spills with water. Use dry cleanup methods such as applying cat litter or another absorbent material, sweep and dispose of in the trash. Take items such as used or excess batteries, oven cleaners, automotive fluids, painting products and cathode ray tubes, like TVs and computer monitors, to a Household Hazardous Waste Collection Center (HHWCC).
- For a HHWCC near you call (714) 834-6752 or visit [www.oilandfills.com](http://www.oilandfills.com).
- Do not hose down your driveway, sidewalk or patio to the street, gutter or storm drain. Sweep up debris and dispose of it in the trash.

## **Automotive**

- Take your vehicle to a commercial car wash whenever possible. If you wash your vehicle at home, choose soaps, cleaners, or detergents labeled non-toxic, phosphate-free or biodegradable. Vegetable and citrus-based products are typically safest for the environment.
- Do not allow washwater from vehicle washing to drain into the street, gutter or storm drain. Excess washwater should be disposed of in the sanitary sewer (through a sink or toilet) or onto an absorbent surface like your lawn.
- Monitor your vehicles for leaks and place a pan under leaks. Keep your vehicles well maintained to stop and prevent leaks.
- Never pour oil or antifreeze in the street, gutter or storm drain. Recycle these substances at a service station, a waste oil collection center or used oil recycling center. For the nearest Used Oil Collection Center call 1-800-CLEANUP or visit [www.1800cleanup.org](http://www.1800cleanup.org).

## **Pool Maintenance**

- Pool and spa water must be dechlorinated and free of excess acid, alkali or color to be allowed in the street, gutter or storm drain.
- When it is not raining, drain dechlorinated pool and spa water directly into the sanitary sewer.
- Some cities may have ordinances that do not allow pool water to be disposed of in the storm drain. Check with your city.

## **Landscape and Gardening**

- Do not over-water. Water your lawn and garden by hand to control the amount of water you use or set irrigation systems to reflect seasonal water needs. If water flows off your yard onto your driveway or sidewalk, your system is over-watering. Periodically inspect and fix leaks and misdirected sprinklers.
- Do not rake or blow leaves, clippings or pruning waste into the street, gutter or storm drain. Instead, dispose of waste by composting, hauling it to a permitted landfill, or as green waste through your city's recycling program.
- Follow directions on pesticides and fertilizer, (measure, do not estimate amounts) and do not use if rain is predicted within 48 hours.
- Take unwanted pesticides to a HHWCC to be recycled. For locations and hours of HHWCC, call (714) 834-6752 or visit [www.oilandfills.com](http://www.oilandfills.com).

## **Trash**

- Place trash and litter that cannot be recycled in securely covered trash cans.
- Whenever possible, buy recycled products.
- Remember: Reduce, Reuse, Recycle.

## **Pet Care**

- Always pick up after your pet. Flush waste down the toilet or dispose of it in the trash. Pet waste, if left outdoors, can wash into the street, gutter or storm drain.
- If possible, bathe your pets indoors. If you must bathe your pet outside, wash it on your lawn or another absorbent/permeable surface to keep the washwater from entering the street, gutter or storm drain.
- Follow directions for use of pet care products and dispose of any unused products at a HHWCC.

## **Common Pollutants**

### **Home Maintenance**

- Detergents, cleaners and solvents
- Oil and latex paint
- Swimming pool chemicals
- Outdoor trash and litter

### **Lawn and Garden**

- Pet and animal waste
- Pesticides
- Clippings, leaves and soil
- Fertilizer

### **Automobile**

- Oil and grease
- Radiator fluids and antifreeze
- Cleaning chemicals
- Brake pad dust



**C**lean beaches and healthy creeks, rivers, bays and ocean are important to Orange County. However, if we are not careful, our daily activities can lead directly to water pollution problems. Water that drains through your watershed can pick up pollutants which are then transported to our waterways and beautiful ocean.

You can prevent water pollution by taking personal action and by working with members of your watershed community to prevent urban runoff from entering your waterway.

For more information, please call the **Orange County Stormwater Program** at **1.877.89.SPILL** or visit [www.ocwatersheds.com](http://www.ocwatersheds.com)

To report a spill, call the **Orange County 24-Hour Water Pollution Problem Reporting Hotline** at **1.877.89.SPILL**.

**For emergencies, dial 911.**

The tips contained in this brochure provide useful information to help protect your watershed. If you have other suggestions, please contact your city's stormwater representatives or call the Orange County Stormwater Program.



Printed on Recycled Paper

# Help Prevent Ocean Pollution: Tips For Protecting Your Watershed

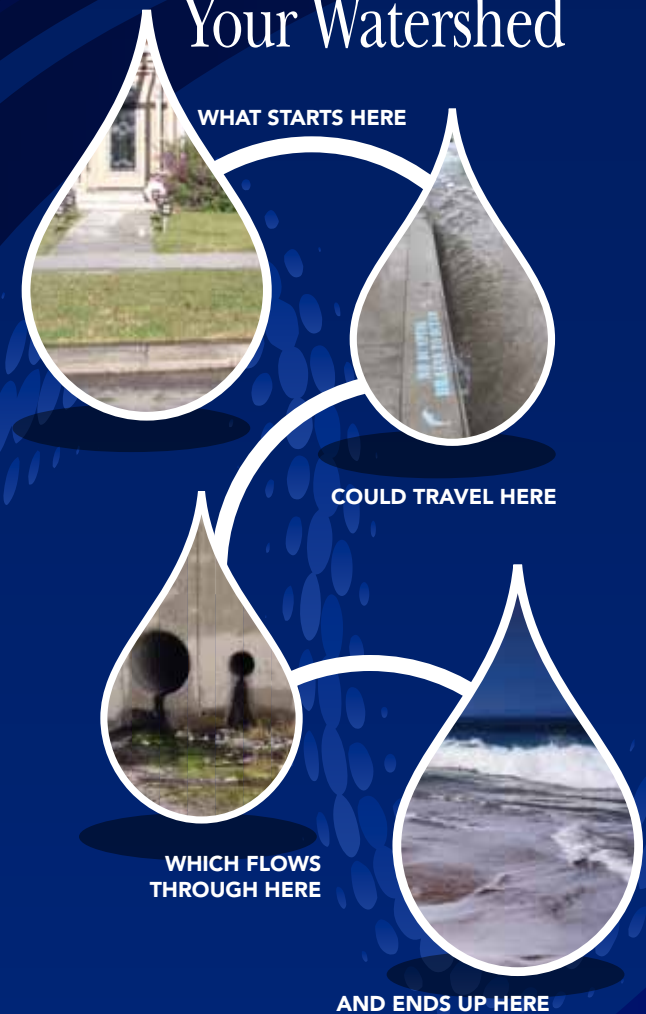

The Ocean Begins  
at Your Front Door





***Did you know that just one quart of oil can pollute 250,000 gallons of water?***

A clean ocean and healthy creeks, rivers, bays and beaches are important to Orange County. However, not properly disposing of used oil can lead to water pollution. If you pour or drain oil onto driveways, sidewalks or streets, it can be washed into the storm drain. Unlike water in sanitary sewers (from sinks and toilets), water in storm drains is not treated before entering the ocean. Help prevent water pollution by taking your used oil to a used oil collection center.

Included in this brochure is a list of locations that will accept up to five gallons of used motor oil at no cost. Many also accept used oil filters. Please contact the facility before delivering your used oil. This listing of companies is for your reference and does not constitute a recommendation or endorsement of the company.

Please note that used oil filters may not be disposed of with regular household trash. They must be taken to a household hazardous waste collection or recycling center in Anaheim, Huntington Beach, Irvine or San Juan Capistrano. For information about these centers, visit [www.oilandfills.com](http://www.oilandfills.com).

Please do not mix your oil with other substances!

For more information, please call the Orange County Stormwater Program at 1-877-89-SPILL (1-877-897-7455) or visit [www.watersheds.com](http://www.watersheds.com).

For information about the proper disposal of household hazardous waste, call the Household Waste Hotline at (714) 834-6752 or visit [www.oilandfills.com](http://www.oilandfills.com).



For additional information about the nearest oil recycling center, call the Used Oil Program at 1-800-CLEANUP or visit [www.cleanup.org](http://www.cleanup.org).

**Help Prevent Ocean Pollution:**

# **Recycle at Your Local Used Oil Collection Center**

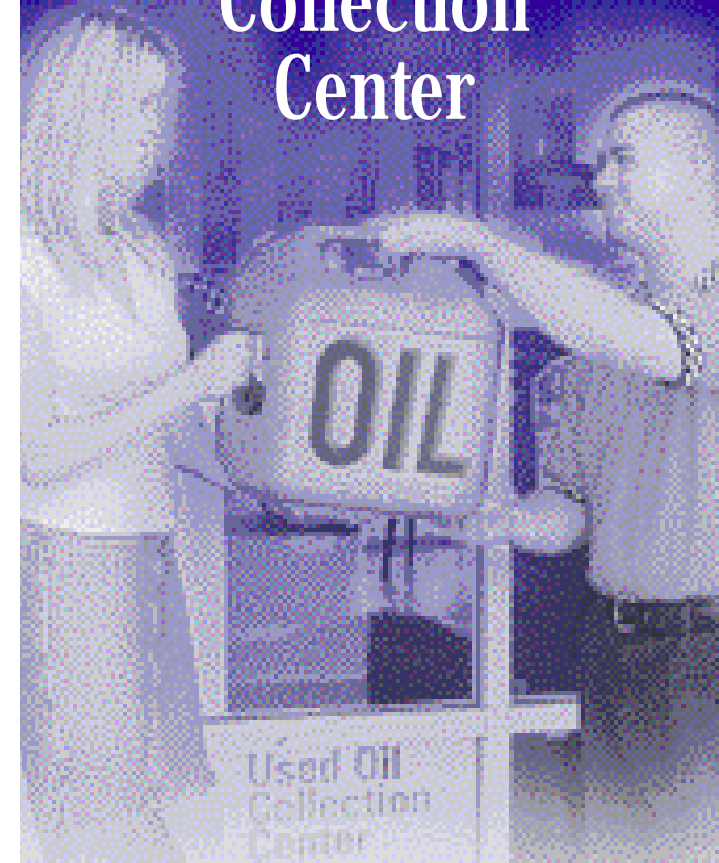

**The Ocean Begins at Your Front Door**



**SOUTH COUNTY**

# Used Oil Collection Centers

## ALISO VIEJO

Big O Tires  
27812 Aliso Creek Rd, Suite E-100  
(949) 362-4225

Econo Lube N' Tune  
22932 Glenwood Dr.  
(949) 643-9667

Jiffy Lube  
27832 Aliso Creek Road  
(949) 362-0005

Pep Boys  
26881 Aliso Creek Road  
(949) 362-9254

EZ Lube  
26731 Rancho Parkway  
(949) 465-9912

Firestone Store  
24421 Rockfield Blvd.  
(949) 581-2660

Jiffy Lube  
20781 Lake Forest Dr.  
(949) 583-0470

Kragen Auto Parts  
24601 Raymond Way  
(949) 829-8292

Pep Boys  
22671 Lake Forest Dr.  
(949) 855-9593

Ryan's Foothill Ranch Transmission  
20622 Pascal Way (949) 770-6888

USA Express Tire & Service  
24561 Trabuco Rd (949) 454-8001

EZ Lube  
24281 Moulton Pkwy.  
(949) 830-9840

EZ Lube  
26921 Moulton Pkwy.  
(949) 751-3436

Kragen Auto Parts  
26562 Moulton Ave.  
(949) 831-0434

Firestone Store  
24196 Laguna Hills Mall  
(949) 581-4700

Oilmax 10 Minute Lube  
25800 Jeronimo Rd. #300  
(949) 859-9271

Ramona Auto Service  
27210 La Paz Rd. (949) 583-1233

## RANCHO SANTA MARGARITA

Jiffy Lube  
23401 Antonio Parkway  
(949) 589-7447

## DANA POINT

Dana Point Fuel Dock  
34661 Puerto Pl. (949) 496-6113

EZ Lube Inc.  
34242 Doheny Park Rd.  
(949) 477-1223

## MISSION VIEJO

AAA Complete Auto Care & Tire  
27913 Center Street  
(949) 347-8200

Autobahn West  
25800 Jeronimo Rd. Suite 401  
(949) 770-2312

## SAN CLEMENTE

EZ Lube  
525 Avenida Pico (949) 940-1850

Kragen Auto Parts  
1113 S. El Camino Real  
(949) 492-9850

Kragen Auto Parts  
400 Camino de Estrella  
(949) 240-9195

San Clemente Car Wash & Oil  
1731 N. El Camino Real  
(949) 847-4924

## FOOTHILL RANCH

USA Express Tire & Service  
26492 Town Center Dr.  
(714) 826-1001

## LAGUNA NIGUEL

Econo Lube N Tune  
27912 Forbes Rd. (949) 364-5833

Laguna Niguel Auto Center  
26042 Cape Dr. #12  
(949) 582-2191

## LAGUNA BEACH

USA Express Tire & Service Inc.  
350 Broadway (949) 494-7111

## LAGUNA HILLS

David J Phillips Buick  
24888 Alicia Pkwy.  
(949) 831-0434

Auto Zone  
22942 Los Alisos (949) 830-8181

Econo Lube & Tune  
25902 El Paseo (949) 582-5483

Jiffy Lube  
27240 La Paz Rd. (949) 455-0470

Kragen Auto Parts  
24510 Alicia Pkwy. (949) 951-9175

Mission Viejo Chevron  
27742 Crown Vly. Pkwy.  
(949) 364-0137

## SAN JUAN CAPISTRANO

Saturn of San Juan Capistrano  
33033 Camino Capistrano  
(949) 248-5411

Texaco Xpress Lube  
27201 Ortega Hwy.  
(949) 489-8008

## LAKE FOREST

Big O Tires  
20742 Lake Forest Dr.  
(949) 443-4155

# Sewage Spill Regulatory Requirements

Allowing sewage to discharge to a gutter or storm drain may subject you to penalties and/or out-of-pocket costs to reimburse cities or public agencies for clean-up efforts.

Here are the pertinent codes, fines, and agency contact information that apply.

## Orange County Stormwater Program

24 Hour Water Pollution Reporting Hotline

1-877-89-SPILL (1-877-897-7455)

- County and city water quality ordinances prohibit discharges containing pollutants.

## Orange County Health Care Agency Environmental Health

(714) 433-6419

California Health and Safety Code, Sections 5410-5416

- No person shall discharge raw or treated sewage or other waste in a manner that results in contamination, pollution or a nuisance.
- Any person who causes or permits a sewage discharge to any state waters:
  - must immediately notify the local health agency of the discharge.
  - shall reimburse the local health agency for services that protect the public's health and safety (water-contact receiving waters).
  - who fails to provide the required notice to the local health agency is guilty of a misdemeanor and shall be punished by a fine (between \$500-\$1,000) and/or imprisonment for less than one year.

## Regional Water Quality Control Board Santa Ana Region San Diego Region

(951) 782-4130

(858) 467-2952

- Requires the prevention, mitigation, response to and reporting of sewage spills.

## California Office of Emergency Services

(800) 852-7550

California Water Code, Article 4, Chapter 4, Sections 13268-13271  
California Code of Regulations, Title 23, Division 3, Chapter 9.2, Article 2, Sections 2250-2260

- Any person who causes or permits sewage in excess of 1,000 gallons to be discharged to state waters shall immediately notify the Office of Emergency Services.
- Any person who fails to provide the notice required by this section is guilty of a misdemeanor and shall be punished by a fine (less than \$20,000) and/or imprisonment for not more than one year.

# Sewage Spill Reference Guide

## Your Responsibilities as a Private Property Owner

Residences  
Businesses  
Homeowner/Condominium Associations  
Federal and State Complexes  
Military Facilities



Orange County  
Sanitation District



Health Care Agency  
Environmental Health



www.ocwatersheds.com

This brochure was designed courtesy of the Orange County Sanitation District (OCS D).  
For additional information, call (714) 962-2411, or visit their website at www.ocsd.com

# What is a Sewage Spill?

Sewage spills occur when the wastewater being transported via underground pipes overflows through a manhole, cleanout or broken pipe. Sewage spills can cause health hazards, damage to homes and businesses, and threaten the environment, local waterways and beaches.

## Common Causes of Sewage Spills

**Grease** builds up inside and eventually blocks sewer pipes. Grease gets into the sewer from food establishments, household drains, as well as from poorly maintained commercial grease traps and interceptors.

**Structure problems** caused by tree roots in the lines, broken/cracked pipes, missing or broken cleanout caps or undersized sewers can cause blockages.

**Infiltration and inflow (I/I)** impacts pipe capacity and is caused when groundwater or rainwater enters the sewer system through pipe defects and illegal connections.

## You Are Responsible for a Sewage Spill Caused by a Blockage or Break in Your Sewer Lines!

Time is of the essence in dealing with sewage spills. You are required to **immediately**:

**Control and minimize the spill.** Keep spills contained on private property and out of gutters, storm drains and public waterways by shutting off or not using the water.

**Use sandbags, dirt and/or plastic sheeting** to prevent sewage from entering the storm drain system.

**Clear the sewer blockage.** Always wear gloves and wash your hands. It is recommended that a plumbing professional be called for clearing blockages and making necessary repairs.

**Always notify your city sewer/public works department or public sewer district of sewage spills.** If the spill enters the storm drains also notify the Health Care Agency. In addition, if it exceeds 1,000 gallons notify the Office of Emergency Services. Refer to the numbers listed in this brochure.

Overflowing  
cleanout pipe  
located on  
private property



## You Could Be Liable

Allowing sewage from your home, business or property to discharge to a gutter or storm drain may subject you to penalties and/or out-of-pocket costs to reimburse cities or public agencies for clean-up and enforcement efforts. See Regulatory Codes & Fines section for pertinent codes and fines that apply.

## What to Look For

Sewage spills can be a very noticeable gushing of water from a manhole or a slow water leak that may take time to be noticed. Don't dismiss unaccounted-for wet areas.

Look for:

- Drain backups inside the building.
- Wet ground and water leaking around manhole lids onto your street.
- Leaking water from cleanouts or outside drains.
- Unusual odorous wet areas: sidewalks, external walls or ground/landscape around a building.

## Caution

Keep people and pets away from the affected area. Untreated sewage has high levels of disease-causing viruses and bacteria. Call your local health care agency listed on the back for more information.

**If You See a Sewage Spill Occurring,  
Notify Your City Sewer/Public Works  
Department or Public Sewer District  
IMMEDIATELY!**

# How a Sewer System Works

A property owner's sewer pipes are called service laterals and are connected to larger local main and regional trunk lines. Service laterals run from the connection at the home to the connection with the public sewer (including the area under the street). These laterals are the responsibility of the property owner and must be maintained by the property owner. Many city agencies have adopted ordinances requiring maintenance of service laterals. Check with your city sewer/local public works department for more information.

Operation and maintenance of **local and regional sewer lines** are the responsibility of the city sewer/public works departments and public sewer districts.

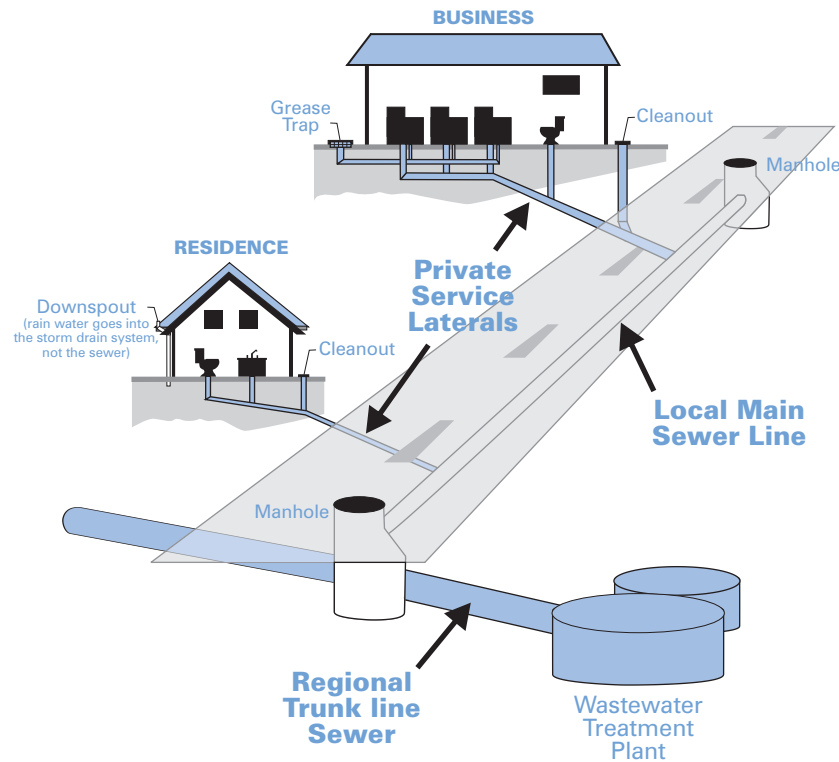

## Preventing Grease Blockages

The drain is not a dump! Recycle or dispose of grease properly and never pour grease down the drain.

Homeowners should mix fats, oils and grease with absorbent waste materials such as paper, coffee grounds, or kitty litter and place it in the trash. Wipe food scraps from plates and pans and dump them in the trash.

Restaurants and commercial food service establishments should always use "Kitchen Best Management Practices." These include:

- Collecting all cooking grease and liquid oil from pots, pans and fryers in covered grease containers for recycling.
- Scraping or dry-wiping excess food and grease from dishes, pots, pans and fryers into the trash.
- Installing drain screens on all kitchen drains.
- Having spill kits readily available for cleaning up spills.
- Properly maintaining grease traps or interceptors by having them serviced regularly. Check your local city codes.

### How You Can Prevent Sewage Spills

- 1 Never put grease down garbage disposals, drains or toilets.**
- 2 Perform periodic cleaning to eliminate grease, debris and roots in your service laterals.**
- 3 Repair any structural problems in your sewer system and eliminate any rainwater infiltration/inflow leaks into your service laterals.**

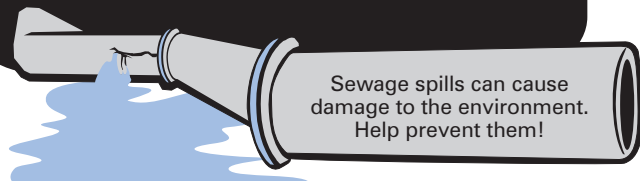

# Orange County Agency Responsibilities

- **City Sewer/Public Works Departments**— Responsible for protecting city property and streets, the local storm drain system, sewage collection system and other public areas.
- **Public Sewer/Sanitation District**— Responsible for collecting, treating and disposing of wastewater.
- **County of Orange Health Care Agency**— Responsible for protecting public health by closing ocean/bay waters and may close food-service businesses if a spill poses a threat to public health.
- **Regional Water Quality Control Boards**— Responsible for protecting State waters.
- **Orange County Stormwater Program**— Responsible for preventing harmful pollutants from being discharged or washed by stormwater runoff into the municipal storm drain system, creeks, bays and the ocean.

### You Could Be Liable for Not Protecting the Environment

Local and state agencies have legal jurisdiction and enforcement authority to ensure that sewage spills are remedied.

They may respond and assist with containment, relieving pipe blockages, and/or clean-up of the sewage spill, especially if the spill is flowing into storm drains or onto public property.

**A property owner may be charged for costs incurred by these agencies responding to spills from private properties.**

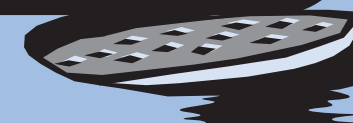

# Report Sewage Spills!

## City Sewer/Public Works Departments

Aliso Viejo	(949) 425-2500
Anaheim	(714) 765-6860
Brea	(714) 990-7691
Buena Park	(714) 562-3655
Costa Mesa	(949) 645-8400
Cypress	(714) 229-6760
Dana Point	(949) 248-3562
Fountain Valley	(714) 593-4600
Fullerton	(714) 738-6897
Garden Grove	(714) 741-5375
Huntington Beach	(714) 536-5921
Irvine	(949) 453-5300
Laguna Beach	(949) 497-0765
Laguna Hills	(949) 707-2650
Laguna Niguel	(949) 362-4337
Laguna Woods	(949) 639-0500
La Habra	(562) 905-9792
Lake Forest	(949) 461-3480
La Palma	(714) 690-3310
Los Alamitos	(562) 431-3538
Mission Viejo	(949) 831-2500
Newport Beach	(949) 644-3011
Orange	(714) 532-6480
Orange County	(714) 567-6363
Placentia	(714) 993-8245
Rancho Santa Margarita	(949) 635-1800
San Clemente	(949) 366-1553
San Juan Capistrano	(949) 443-6363
Santa Ana	(714) 647-3380
Seal Beach	(562) 431-2527
Stanton	(714) 379-9222
Tustin	(714) 962-2411
Villa Park	(714) 998-1500
Westminster	(714) 893-3553
Yorba Linda	(714) 961-7170

## Public Sewer/Water Districts

Costa Mesa Sanitary District	(714) 393-4433/ (949) 645-8400
El Toro Water District	(949) 837-0660
Emerald Bay Service District	(949) 494-8571
Garden Grove Sanitary District	(714) 741-5375
Irvine Ranch Water District	(949) 453-5300
Los Alamitos/Rossmoor Sewer District	(562) 431-2223
Midway City Sanitary District (Westminster)	(714) 893-3553
Moulton Niguel Water District	(949) 831-2500
Orange County Sanitation District	(714) 962-2411
Santa Margarita Water District	(949) 459-6420
South Coast Water District	(949) 499-4555
South Orange County Wastewater Authority	(949) 234-5400
Sunset Beach Sanitary District	(562) 493-9932
Trabuco Canyon Sanitary District	(949) 858-0277
Yorba Linda Water District	(714) 777-3018

## Other Agencies

Orange County Health Care Agency	(714) 433-6419
Office of Emergency Services	(800) 852-7550



**C**lean beaches and healthy creeks, rivers, bays and ocean are important to Orange County. However, many common activities can lead to water pollution if you're not careful. Pet waste and pet care products can be washed into the storm drains that flow to the ocean. Unlike water in sanitary sewers (from sinks and toilets), water in storm drains is not treated before entering our waterways.

You would never put pet waste or pet care products into the ocean, so don't let them enter the storm drains. Follow these easy tips to help prevent water pollution.

For more information, please call the **Orange County Stormwater Program** at **1-877-89-SPILL** (1-877-897-7455) or visit **www.ocwatersheds.com**

To report a spill, call the **Orange County 24-Hour Water Pollution Problem Reporting Hotline** **1-877-89-SPILL** (1-877-897-7455).

**For emergencies, dial 911.**

The tips contained in this brochure provide useful information to help prevent water pollution while caring for your pet. If you have other suggestions, please contact your city's stormwater representatives or call the Orange County Stormwater Program.



Printed on Recycled Paper

Help Prevent Ocean Pollution:

## Tips for Pet Care

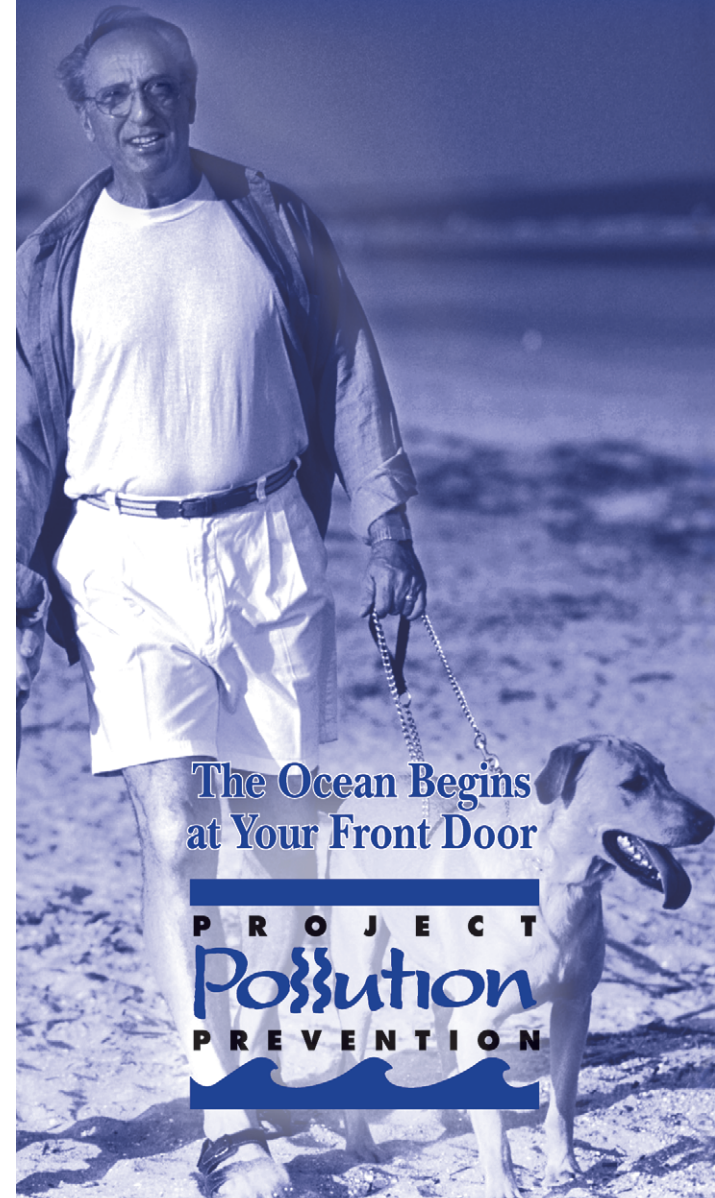

# Tips for Pet Care

Never let any pet care products or washwater run off your yard and into the street, gutter or storm drain.

## *Washing Your Pets*

Even biodegradable soaps and shampoos can be harmful to marine life and the environment.

- If possible, bathe your pets indoors using less-toxic shampoos or have your pet professionally groomed. Follow instructions on the products and clean up spills.
- If you bathe your pet outside, wash it on your lawn or another absorbent/permeable surface to keep the washwater from running into the street, gutter or storm drain.



## *Flea Control*

- Consider using oral or topical flea control products.
- If you use flea control products such as shampoos, sprays or collars, make sure to dispose of any unused products at a Household Hazardous Waste Collection Center. For location information, call (714) 834-6752.



## *Why You Should Pick Up After Your Pet*

It's the law! Every city has an ordinance requiring you to pick up after your pet. Besides being a nuisance, pet



waste can lead to water pollution, even if you live inland. During rainfall, pet waste left outdoors can wash into storm drains. This waste flows directly into our waterways and the ocean where it can harm human health, marine life and the environment.

As it decomposes, pet waste demands a high level of oxygen from water. This decomposition can contribute to killing marine life by reducing the amount of dissolved oxygen available to them.

Have fun with your pets, but please be a responsible pet owner by taking care of them and the environment.

- Take a bag with you on walks to pick up after your pet.
- Dispose of the waste in the trash or in a toilet.



# Tips for Protecting Your Watershed

## My Watershed. Our Ocean.

**Water + shed**, noun: A region of land within which water flows down into a specified water body, such as a river, lake, sea, or ocean; a drainage basin or catchment basin.

Orange County is comprised of 11 major watersheds into which most of our water flows, connecting all of Orange County to the Pacific Ocean.



As water from rain (stormwater) or sprinklers and hoses (urban runoff) runs down your driveway and into your neighborhood streets, sidewalks

and gutters, it flows into storm drains that lead to waterways within your watershed. The waterways from other cities merge as they make their way through our watersheds until all the runoff water in Orange County meets at the Pacific Ocean. The water that reaches our ocean is not pure. As it flows through the watershed, it picks up pollutants such as litter, cigarette butts, fertilizer, pesticides, pet waste, motor oil and lawn clippings. Unlike water that enters the sewer (from sinks and toilets), water that enters the storm drain is not treated before it flows, ultimately, to the ocean.

Water quality can be improved by “Adopting Your Watershed.” Through this effort, we are challenging citizens and



organizations to join the Orange County Stormwater Program and others who are working to protect and restore our creeks, rivers, bays and ocean.

### There are many opportunities to get involved:

- Appreciate your watershed - explore the creeks, trails and ocean and make observations about its conditions. If you see anything abnormal (such as dead fish, oil spills, leaking barrels, and other pollution) contact the Orange County 24-hour water pollution problem reporting hotline at 1.877.89.SPILL to report the problem.
- Research your watershed. Learn about what watershed you live in by visiting [www.ocwatersheds.com](http://www.ocwatersheds.com).
- Find a watershed organization in your community and volunteer to help. If there are no active groups, consider starting your own.
- Visit EPA’s Adopt Your Watershed’s Catalog of Watershed Groups at [www.epa.gov/adopt](http://www.epa.gov/adopt) to locate groups in your community.
- Organize or join in a creek, river, bay or ocean cleanup event such as Coastal & Inner Coastal Cleanup Day that takes place the 3rd Saturday of every September. For more information visit [www.coast4u.org](http://www.coast4u.org).

### Follow these simple tips to protect the water quality of your watershed:

- Sweep up debris and dispose of it in the trash. Do not hose down driveways or sidewalks into the street or gutter.
- Use dry cleanup methods such as cat litter to absorb spills and sweep up residue.
- Set your irrigation systems to reflect seasonal water needs or use weather-based controllers. Inspect for runoff regularly.
- Cover trashcans securely.
- Take hazardous waste to a household hazardous waste collection center. (For example, paint, batteries and petroleum products)
- Pick up after your pet.
- Follow application and disposal directions for pesticides and fertilizers.
- If you wash your car at home, wash it on your lawn or divert the runoff onto a landscaped area. Consider taking your car to a commercial car wash, where the water is reclaimed or recycled.
  - Keep your car well maintained.
  - Never pour oil or antifreeze in the street, gutter or storm drain.





# DF-1 DRAINAGE FACILITY OPERATION AND MAINTENANCE

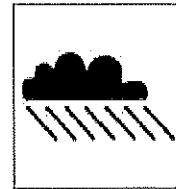

As a consequence of its function, the stormwater conveyance system collects and transports urban runoff and storm water that may contain certain pollutants. Consequently these pollutants may accumulate in the system and must be removed periodically. In addition, the systems must also be maintained to function properly hydraulically to avoid flooding. Maintaining the system may involve the following activities:

1. Inspection and Cleaning of Stormwater Conveyance Structures
2. Controlling Illicit Connections and Discharges
3. Controlling Illegal Dumping

This list of Model Maintenance Procedures can be utilized as an inspection checklist to determine where better compliance with Designated Minimum Best Management Practices (notated with checkmarks and capital letters) is needed, and to recommend Additional Best Management Practices (notated with bullet points and lower case letters) that may be applicable under certain circumstances, especially where there are certain Pollutant Constituents of Concern. BMPs applicable to certain constituents are notated as:

*Bacteria (BACT)      Sediment (SED)      Nutrients (NUT)      Oil and Grease (O&G)      Pesticides (PEST)*  
*Other Toxic Compounds (TOX)      Trash (TRASH)      Hydrological Impacts (HYD)      Any/All or General (ANY)*

Program/Facility Being Inspected: \_\_\_\_\_

Date: \_\_\_\_\_ Inspector Name: \_\_\_\_\_

When completed, the checklist should be attached to the General Inspection Form Cover Sheet and copies should be provided to the Supervisor of the Facility/Program being inspected.

## MAINTENANCE PROCEDURES:

### 1. Inspection and Cleaning of Drainage Facilities

Unsatisfactory	OK
<input type="checkbox"/> _____	<input type="checkbox"/>
<input type="checkbox"/> _____	<input type="checkbox"/>
<input type="checkbox"/> _____	<input type="checkbox"/>
<input type="checkbox"/> _____	<input type="checkbox"/>
<input type="checkbox"/> _____	<input type="checkbox"/>
<input type="checkbox"/> _____	<input type="checkbox"/>
<input type="checkbox"/> _____	<input type="checkbox"/>
<input type="checkbox"/> _____	<input type="checkbox"/>

**General Guidelines**

T 1A. Annually inspect and clean drainage structures as needed.

T 1B. Maintain appropriate records of cleaning and inspections.

T 1C. Properly dispose of removed materials at a landfill or recycling facility.

T 1D. Conduct intermittent supplemental visual inspections during the wet season to determine if there are problem inlets where sediment/trash or other pollutants accumulate, and provide for additional cleanouts as appropriate.

T 1E. Prevent or clean up any discharges that may occur during the course of maintenance and cleaning procedures.

T 1F. Verify that appropriate employees or subcontractors are trained in proper conductance of maintenance activities, including record keeping and disposal.

T 1G. Annually inspect and clean v-ditches as needed, prior to the wet season. On shrub-covered slopes, vegetative debris may be placed on the downhill side of the ditch. Trash should be bagged and disposed at a landfill.



<p><b>2. Controlling Illicit Connections and Discharges</b></p>	
<p><b>Unsatisfactory</b></p> <p><input type="checkbox"/> _____ <input type="checkbox"/></p> <p>_____</p> <p>_____</p> <p><input type="checkbox"/> _____ <input type="checkbox"/></p> <p>_____</p> <p>_____</p> <p><input type="checkbox"/> _____ <input type="checkbox"/></p> <p>_____</p> <p>_____</p> <p><input type="checkbox"/> _____ <input type="checkbox"/></p> <p>_____</p> <p>_____</p> <p><input type="checkbox"/> _____ <input type="checkbox"/></p> <p>_____</p> <p>_____</p>	<p><b>OK</b></p> <p><input type="checkbox"/></p> <p><input type="checkbox"/></p> <p><input type="checkbox"/></p> <p><input type="checkbox"/></p> <p><input type="checkbox"/></p> <p><input type="checkbox"/></p> <p><input type="checkbox"/></p> <p><input type="checkbox"/></p> <p><input type="checkbox"/></p>
<p><b>General Guidelines</b></p> <p>T 2A. Report prohibited discharges such as dumping, paint spills, abandoned oil containers, etc. observed during the course of normal daily activities so they can be investigated, contained, and cleaned up.</p> <p>T 2B. Where field observations and/or monitoring data indicate significant problems, conduct field investigations to detect and eliminate existing illicit connections and improper disposal of pollutants into the storm drain (i.e. identify problem areas where discharges or illegal connections may occur and follow up stream to determine the source(s)). (Refer to Appendices A-10 and A-11.)</p> <p>T 2C. Report all observed illicit connections and discharges to the 24-hour water pollution problem reporting hotline (714) 567-6363.</p> <p>T 2D. Encourage public reporting of improper waste disposal by distributing public education materials and advertising the 24-hour water pollution problem reporting hotline.</p> <p><b>Storm Drain Stenciling ("No Dumping—Drains to Ocean")</b></p> <p>T 2E. Implement and maintain a storm drain stenciling program.</p> <ul style="list-style-type: none"> <li>• 2a. Consider adding the hotline number to the storm drain stencils (BACT, TOX, TRASH).</li> </ul>	
<p><b>3. Controlling Illegal Dumping</b></p>	
<p><input type="checkbox"/> _____ <input type="checkbox"/></p> <p>_____</p> <p><input type="checkbox"/> _____ <input type="checkbox"/></p> <p>_____</p> <p>_____</p> <p><input type="checkbox"/> _____ <input type="checkbox"/></p> <p>_____</p> <p>_____</p> <p><input type="checkbox"/> _____ <input type="checkbox"/></p> <p>_____</p> <p>_____</p> <p><input type="checkbox"/> _____ <input type="checkbox"/></p> <p>_____</p> <p>_____</p>	<p><input type="checkbox"/></p> <p><input type="checkbox"/></p> <p><input type="checkbox"/></p> <p><input type="checkbox"/></p> <p><input type="checkbox"/></p> <p><input type="checkbox"/></p> <p><input type="checkbox"/></p> <p><input type="checkbox"/></p> <p><input type="checkbox"/></p>
<p><b>Field Investigation</b></p> <p>T 3A. Report prohibited discharges such as dumpings observed during the course of normal daily activities so they can be investigated, contained and cleaned up.</p> <p>T 3B. Conduct field investigations to detect and eliminate improper disposal of pollutants into the storm drain (i.e. identify problem areas where discharges or illegal connections may occur and follow up stream to determine the source(s)).</p> <p>T 3C. Report all observed illegal dumping to the 24-hour water pollution problem reporting hotline (714) 567-6363.</p> <p>T 3D. Encourage public reporting of improper waste disposal by distributing public education materials and advertising the 24-hour water pollution problem reporting hotline.</p> <p>T 3E. If perpetrator can be identified, take appropriate enforcement action.</p> <ul style="list-style-type: none"> <li>• 3a. Consider posting "No Dumping" signs in problem areas with a phone number for reporting dumping and disposal. Signs could also indicate fines and penalties for illegal dumping. (ANY)</li> </ul>	

<p><b>Unsatisfactory</b>                      <b>OK</b></p> <p><input type="checkbox"/> _____ <input type="checkbox"/></p> <p>_____</p> <p><input type="checkbox"/> _____ <input type="checkbox"/></p> <p>_____</p> <p><input type="checkbox"/> _____ <input type="checkbox"/></p> <p>_____</p> <p>_____</p> <p>_____</p>	<p><b>Training/Education/Outreach</b></p> <p>T 3F. Verify that appropriate employees and subcontractors are trained to recognize and report illegal dumping.</p> <p>T 3G. Encourage public reporting of illegal dumping by advertising the 24-hour water pollution problem reporting hotline (714) 567-6363.</p> <ul style="list-style-type: none"> <li>• 3b. Take extra steps to educate the public in neighborhoods where illegal dumping has occurred to inform them why illegal dumping is a problem, and that illegal dumping carries a significant financial penalty. (ANY)</li> </ul>
---	--

**LIMITATIONS:**

Clean-up activities may create a slight disturbance for local aquatic species. Access to items and material on private property may be limited. Trade-offs may exist between channel hydraulics and water quality/riparian habitat. If storm channels or basins are recognized as wetlands, many activities, including maintenance, may be subject to regulation and permitting.

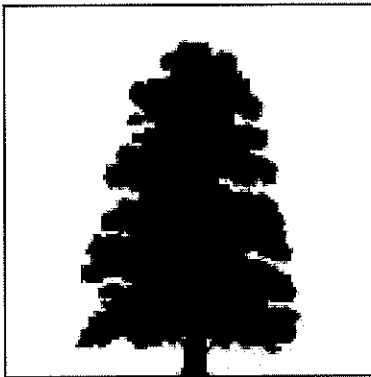

## LANDSCAPE MAINTENANCE

The model procedures described below focus on minimizing the discharge of pesticides and fertilizers, landscape waste, trash, debris, and other pollutants to the storm drain system and receiving waters. Landscape maintenance practices may involve one or more of the following activities:

1. **Mowing, Trimming/Weeding, and Planting**
2. **Irrigation**
3. **Fertilizer and Pesticide Management**
4. **Managing Landscape Waste**
5. **Erosion Control**

### POLLUTION PREVENTION:

Pollution prevention measures have been considered and incorporated in the model procedures. Implementation of these measures may be more effective and reduce or eliminate the need to implement other more complicated or costly procedures. Possible pollution prevention measures for landscape maintenance include:

- Implement an integrated pest management (IPM) program. IPM is a sustainable approach to managing pests by combining biological, cultural, physical, and chemical tools. Refer to Appendix D, Fertilizer and Pesticide Guidance for further details.
- Choose low water using flowers, trees, shrubs, and groundcover.
- Consider the selection of broadleaf evergreen trees to reduce leaf litter.
- Appropriate maintenance (i.e. properly timed fertilizing, weeding, pest control, and pruning) to preserve the landscapes water efficiency.
- Once per year, educate municipal staff on pollution prevention measures.

### MODEL PROCEDURES:

#### 1. Mowing, Trimming/Weeding, and Planting

**Mowing,** ✓ If feasible and practical, use mechanical methods of vegetation removal

## Trimming/Weeding

rather than applying herbicides. Use hand weeding where practical.

- ✓ When conducting mechanical or manual weed control, avoid loosening the soil, which could erode into streams or storm drains.
- ✓ If feasible and practical, use coarse textured mulches or geotextiles to suppress weed growth and reduce the use of herbicides.
- ✓ Do not blow or rake leaves, etc. into the street or place yard waste in gutters or on dirt shoulders. Sweep up any leaves, litter or residue in gutters or on street.
- ✓ Collect lawn and garden clippings, pruning waste, tree trimmings, and weeds. Chip if necessary, and compost or dispose of at a landfill (see waste management section of this procedure sheet).
- ✓ Place temporarily stockpiled material away from watercourses, and berm or cover stockpiles to prevent material releases to storm drains.

## Planting

- ✓ Where feasible, retain and/or plant selected native vegetation whose features are determined to be beneficial. Native vegetation usually requires less maintenance (e.g., irrigation, fertilizer) than planting ornamental vegetation.
- ✓ When planting or replanting consider using low water use groundcovers.

### OPTIONAL:

- Careful soil mixing and layering techniques using a topsoil mix or composted organic material can be used as an effective measure to reduce herbicide use and watering.

## 2. Irrigation

- ✓ Utilize water delivery rates that do not exceed the infiltration rate of the soil.
- ✓ Use timers appropriately or a drip system to prevent runoff and then only irrigate as much as is needed.
- ✓ Inspect irrigation system periodically to ensure that the right amount of water is being applied and that excessive runoff is not occurring. Minimize excess watering, and repair leaks in the irrigation system as needed.
- ✓ Where practical, use automatic timers to minimize runoff.
- ✓ Use popup sprinkler heads in areas with a lot of activity or where there is a chance the pipes may be broken. Consider the use of mechanisms that reduce water flow to sprinkler heads if broken.
- ✓ If re-claimed water is used for irrigation, ensure that there is no runoff from the landscaped area(s).
- ✓ If bailing of muddy water is required (e.g. when repairing a water line leak), do not put it in the storm drain; pour over landscaped areas.

OPTIONAL:

- Consider converting to an evapo-transpiration driven irrigation control system.

## 3. Fertilizer and Pesticide Management

### Usage

- ✓ Utilize a comprehensive management system that incorporates integrated pest management techniques.
- ✓ Follow all federal, state, and local laws and regulations governing the use, storage, and disposal of fertilizers and pesticides and training of applicators and pest control advisors.
- ✓ Educate and train employees on use of pesticides and in pesticide application techniques to prevent pollution.
- ✓ Pesticide application must be under the supervision of a California qualified pesticide applicator.
- ✓ When applicable use the least toxic pesticides that will do the job. Avoid use of copper-based pesticides if possible.
- ✓ Do not mix or prepare pesticides for application near storm drains.
- ✓ Prepare the minimum amount of pesticide needed for the job and use the lowest rate that will effectively control the pest.
- ✓ Employ techniques to minimize off-target application (e.g. spray drift) of pesticides, including consideration of alternative application techniques.
- ✓ Calibrate fertilizer and pesticide application equipment to avoid excessive application.
- ✓ Periodically test soils for determining proper fertilizer use.
- ✓ Sweep pavement and sidewalk if fertilizer is spilled on these surfaces before applying irrigation water.
- ✓ Inspect pesticide/fertilizer equipment and transportation vehicles frequently
- ✓ Refer to Appendix D, Fertilizer and Pesticide Guidance for further details.

OPTIONAL:

- Work fertilizers into the soil rather than dumping or broadcasting onto the surface.
- Use beneficial insects where possible to control pests (green lacewings, ladybugs, praying mantis, ground beetles, parasitic nematodes, trichogramma wasps, seedhead weevils, and spiders prey on detrimental pest species).
- Use slow release fertilizers whenever possible to minimize leaching.

## Scheduling

- ✓ Do not use pesticides if rain is expected within 24 hours.
- ✓ Apply pesticides only when wind speeds are low (less than 5 mph).

## Storage

- ✓ To minimize quantities of pesticides and fertilizers stored, only purchase what is needed for use in the near future.
- ✓ Implement storage requirements for pesticide products with guidance from the local fire department and County Agricultural Commissioner. Provide secondary containment for pesticides.

## Disposal

- ✓ Purchase only the amount of pesticide that you can reasonably use in a given time period (month or year depending on the product).
- ✓ Triple rinse containers, and use rinse water as product. Dispose of unused pesticide as hazardous waste.
- ✓ Dispose of empty pesticide containers according to the instructions on the container label.

## 4. Managing Landscape Waste

*Also see Waste Handling and Disposal procedure sheet*

- ✓ Compost leaves, sticks, or other collected vegetation or dispose of at a permitted landfill. Do not dispose of collected vegetation into waterways or storm drainage systems.
- ✓ Place temporarily stockpiled material away from watercourses and storm drain inlets, and berm or cover stockpiles to prevent material releases to the storm drain system.
- ✓ Reduce the use of high nitrogen fertilizers that produce excess growth requiring more frequent mowing or trimming.
- ✓ Inspection of drainage facilities should be conducted to detect illegal dumping of clippings/cuttings in or near these facilities. Materials found should be picked up and properly disposed of.
- ✓ Landscape wastes in and around storm drain inlets should be avoided by either using bagging equipment or manually picking the material up.

## 5. Erosion Control

- ✓ Maintain vegetative cover on medians and embankments to prevent soil erosion. Apply mulch or leave clippings to serve as additional cover for soil stabilization and to reduce the velocity of storm water runoff.
- ✓ As medians are developed or re-developed, consider designing them so that they prevent runoff and erosion and promote better irrigation practices.
- ✓ Minimize the use of disking as a means of vegetation management because the practice may result in erodable barren soil.

- ✓ Confine excavated materials to pervious surfaces away from storm drain inlets, sidewalks, pavement, and ditches. Material must be covered if rain is expected.

---

## LIMITATIONS:

Alternative pest/weed controls may not be available, suitable, or effective in every case.

## REFERENCES:

*California Storm Water Best Management Practice Handbooks. Industrial/Commercial Best Management Practice Handbook. Prepared by Camp Dresser & McKee, Larry Walker Associates, Uribe and Associates, Resources Planning Associates for Stormwater Quality Task Force. July 1993.*

County of Orange. 2000. Public Facilities and Resources Department, Management Guidelines for the Use of Fertilizers and Pesticides. September.

King County Stormwater Pollution Control Manual. Best Management Practices for Businesses. 1995. King County Surface Water Management. July. On-line: <http://dnr.metrokc.gov/wlr/dss/spcm.htm>

Los Angeles County Stormwater Quality Model Programs. Public Agency Activities  
[http://ladpw.org/wmd/npdes/model\\_links.cfm](http://ladpw.org/wmd/npdes/model_links.cfm)

Model Urban Runoff Program: A How-To Guide for Developing Urban Runoff Programs for Small Municipalities. Prepared by City of Monterey, City of Santa Cruz, California Coastal Commission, Monterey Bay National Marine Sanctuary, Association of Monterey Bay Area Governments, Woodward-Clyde, Central Coast Regional Water Quality Control Board. July. 1998.

Santa Clara Valley Urban Runoff Pollution Prevention Program. 1997 Urban Runoff Management Plan. September 1997, updated October 2000.

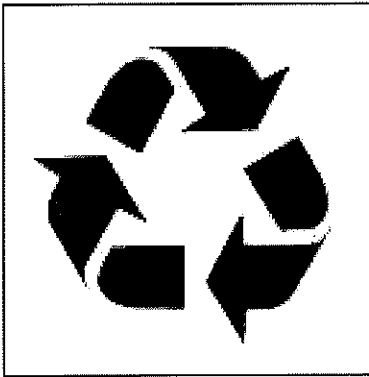

**FF-7**

## **MATERIAL STORAGE, HANDLING, AND DISPOSAL**

**Accidental releases of materials from aboveground liquid storage tanks, drums, and dumpsters present the potential for contaminating stormwater with many different pollutants. Maintaining these areas may involve one or more of the following activities:**

- 1. Material Storage**
- 2. Chemical Material Handling and Disposal**
- 3. Hazardous Material Handling and Disposal**

**Accidental releases of materials from aboveground liquid storage tanks, drums, and dumpsters present the potential for contaminating stormwater with many different pollutants. Maintaining these areas may involve one or more of the following activities:**

### **POLLUTION PREVENTION:**

Pollution prevention measures have been considered and incorporated in the model procedures. Implementation of these measures may be more effective and reduce or eliminate the need to implement other more complicated or costly procedures. Possible pollution prevention measures for material storage, handling, and disposal include:

- Store material indoors, or covered if outdoors.
- Prevent storm water run-on.
- Once per year, educate municipal staff on pollution prevention measures.

### **MODEL PROCEDURES:**

#### **1. General Material Storage, Handling, and Disposal**

##### **Storage**

- ✓ Store materials indoors if possible. If stored outdoors, cover the storage area with a roof or with temporary cover during rain events. [*Note: the local fire authority/department must be consulted for limitations on clearance of roof covers over containers used to store flammable materials*].

# FF-7

- ✓ Keep storage areas clean and dry. Conduct regular inspections so that leaks and spills are detected as soon as possible.
- ✓ Minimize stormwater run-on and runoff by covering, enclosing or providing secondary containment for the area.
- ✓ Keep outdoor storage areas in good condition (e.g. repair roofs, floors, etc. to limit releases to runoff).
- ✓ Drums stored in an area where unauthorized persons may gain access must be secured to prevent accidental spillage, pilferage, or any unauthorized use. Only personnel with proper training may handle hazardous waste. See *Waste Handling and Disposal Procedures*
- ✓ Wood products treated with chromated copper arsenate, ammoniacal copper zinc arsenate, creosote, or pentachlorophenol should be covered with tarps during rain events or stored indoors.
- ✓ Parking lots or other surfaces near bulk materials storage areas should be swept periodically to remove debris blown or washed from storage area.
- ✓ Train employees in proper storage measures.

## Secondary Containment

- ✓ Tanks should be bermed or surrounded by a secondary containment system such as dikes, liners, vaults, or double walled tanks.
- ✓ Keep liquids in a designated area on a paved impervious surface within a secondary containment.
- ✓ The area inside the berm should slope to a drain with a dead-end sump that is periodically pumped out.

## Inspection

- ✓ Inspect storage areas regularly for leaks or spills.
- ✓ Conduct routine inspections and check for external corrosion of material containers. Also check for structural failure, spills and overfills due to operator error, failure of piping system.
- ✓ Check for leaks or spills during pumping of liquids or gases from trucks to a storage facility or vice versa.
- ✓ Visually inspect new tank or container installations for loose fittings, poor welding, and improper or poorly fitted gaskets.
- ✓ Inspect tank foundations, connections, coatings, and tank walls and piping system. Look for corrosion, leaks, cracks, scratches, and other physical damage that may weaken the tank or container system.

## 2. General Chemical Material Handling and Disposal

### General Guidelines

- ✓ Do not store chemicals, drums, or bagged materials directly on the ground. Place these items in secondary containers. Designate a secure chemical material storage area that is paved with Portland cement concrete, free of cracks and gaps, and impervious in order to contain leaks and spills.

*Types of chemical materials that may be stored:*

*Liquid chemicals  
Waste oils  
Solvents  
Petroleum products  
Paints  
Cleaners  
Pesticides  
Fertilizers  
Etc.*

- ✓ Containers should be placed in a designated area and covered.
- ✓ Design and maintain chemical storage areas that reduce exposure to storm water:
  - Store materials inside or under cover on paved surfaces
  - Use secondary containment (see section above)
- ✓ Use covered dumpsters for waste product containers. Dumpsters shall be kept in good condition without corrosion or leaky seams. Garbage dumpsters shall be replaced if they are deteriorating to the point where leakage is occurring.
- ✓ Liquid materials should be stored in UL approved double walled tanks or surrounded by a curb or dike to provide the volume to contain 10 percent of the volume of all the containers or 110 percent of the volume of the largest container, whichever is greater.
- ✓ Try to keep chemicals in their original containers, and keep them well labeled.
- ✓ Keep secured lids on waste barrels and containers.

## Spill Control

*See Spill Prevention and Control procedures sheet*

- ✓ Clean up spills immediately.
- ✓ Safeguards against accidental releases:
  - Overflow protection devices to warn operator or automatic shut down transfer pumps
  - Protection guards (bollards) around tanks and piping to prevent vehicle or forklift damage
- ✓ Clear tagging or labeling, and restricting access to valves to reduce human error.
- ✓ Employees trained in emergency spill cleanup procedures should be present when dangerous waste, liquid chemicals, or other wastes are delivered or transferred off-site.

## 3. General Hazardous Material Handling

### General Guidelines

*Also see Spill Control Section above and the Spill Prevention and Control procedures sheet*

- ✓ All hazardous waste must be labeled according to hazardous waste regulations. Consult your Fire Department or your local hazardous waste agency for details.
- ✓ Store as few hazardous materials on-site as possible. Do not store any hazardous waste directly on the ground. Place these items in secondary containers. Designate a secure hazardous waste storage area that is paved with Portland cement concrete, free of cracks and gaps, and impervious in order to contain leaks and spills.
- ✓ Handle hazardous materials as infrequently as possible. Only properly trained personnel should handle hazardous waste.

# FF-7

- ✓ Storage of oil and hazardous materials must meet specific Federal and State standards including:
  - Spill Prevention Control and Countermeasure Plan
  - Secondary containment
  - Integrity and leak detection monitoring
- ✓ Never mix waste oil with fuel, antifreeze, or chlorinated solvents. Consult your hazardous waste hauler for details.
- ✓ Develop emergency preparedness plans.
- ✓ Employees should be familiar with the Hazardous Materials Disclosure Plan, if applicable .
- ✓ Employees trained in emergency spill cleanup procedures should be present when dangerous waste, liquid chemicals, or other wastes are delivered or transferred off-site.

## Batteries

- ✓ Store new batteries securely to avoid breakage and acid spills during earthquakes. Shelving should be secured to the wall.
- ✓ Store used batteries indoors and in plastic trays to contain potential leaks.
- ✓ Recycle old batteries.

---

## LIMITATIONS:

Storage sheds often must meet building and fire code requirements.

## REFERENCES:

*California Storm Water Best Management Practice Handbooks. Municipal Best Management Practice Handbook. Prepared by Camp Dresser & McKee, Larry Walker Associates, Uribe and Associates, Resources Planning Associates for Stormwater Quality Task Force. March 1993.*

King County Stormwater Pollution Control Manual. Best Management Practices for Businesses. 1995. King County Surface Water Management. July. On-line: <http://dnr.metrokc.gov/wlr/dss/spcm.htm>

Model Urban Runoff Program: A How-To Guide for Developing Urban Runoff Programs for Small Municipalities. Prepared by City of Monterey, City of Santa Cruz, California Coastal Commission, Monterey Bay National Marine Sanctuary, Association of Monterey Bay Area Governments, Woodward-Clyde, Central Coast Regional Water Quality Control Board. July. 1998.

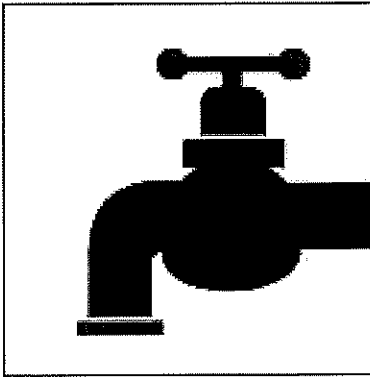

**FP-6**

## **WATER AND SEWER UTILITY OPERATION AND MAINTENANCE**

**Although the operation and maintenance of public utilities are not considered themselves a chronic source of stormwater pollution, some activities and accidents can result in the discharge of pollutants that can pose a threat to both human health and the quality of receiving waters if they enter the storm drain system. Activities associated with the operation and maintenance of water and sewer utilities to prevent and handle such incidents include the following:**

- 1. Water Line Maintenance**
- 2. Sanitary Sewer Maintenance**
- 3. Spill/Leak/Overflow Control, Response, and Containment**

**Cities that do not provide maintenance of water and sewer utilities should coordinate with the contracting agency responsible for these activities and ensure that these model procedures are followed.**

### **POLLUTION PREVENTION:**

Pollution prevention measures have been considered and incorporated in the model procedures. Implementation of these measures may be more effective and reduce or eliminate the need to implement other more complicated or costly procedures. Possible pollution prevention measures for water and sewer utility operation and maintenance include:

- Inspect potential non-storm water discharge flow paths and clear/cleanup any debris or pollutants found (i.e. remove trash, leaves, sediment, and wipe up liquids, including oil spills).
- Once per year, educate municipal staff on pollution prevention measures.

## MODEL PROCEDURES:

### 1. Water Line Maintenance

Procedures can be employed to reduce pollutants from discharges associated with water utility operation and maintenance activities. Planned discharges may include fire hydrant testing, flushing water supply mains after new construction, flushing lines due to complaints of taste and odor, dewatering mains for maintenance work. Unplanned discharges from treated, recycled water, raw water, and groundwater systems operation and maintenance activities can occur from water main breaks, sheared fire hydrants, equipment malfunction, and operator error.

#### Planned Discharges

- ✓ For planned discharges use one of the following options:
  - Reuse water for dust suppression, irrigation, or construction compaction
  - Discharge to the sanitary sewer system with approval
  - Discharge to the storm drain system or to a creek using applicable pollution control measures listed below (this option is ONLY applicable to uncontaminated pumped ground water, water line flushing, fire hydrant testing and flushing, discharges from potable water sources other than water main breaks) and may require a permit from the Regional Water Quality Control Board.
- ✓ If water is discharged to a storm drain inlet (catch basin), control measures must be put in place to control potential pollutants (i.e. sediment, chlorine, etc.). Examples of some storm drain inlet protection options include:
  - Silt fence – appropriate where the inlet drains a relatively flat area.
  - Gravel and wire mesh sediment filter – Appropriate where concentrated flows are expected.
  - Wooden weir and fabric – use at curb inlets where a compact installation is desired.
- ✓ Prior to discharge, inspect discharge flow path and clear/cleanup any debris or pollutants found (i.e. remove trash, leaves, sediment, and wipe up liquids, including oil spills).
- ✓ Select appropriate pollution control measure(s) considering the receiving system (i.e. curb inlet, drop inlet, culvert, creek, etc.) and ensure that the control device(s) fit properly.

- ✓ General design considerations for inlet protection devices include the following:
  - The device should be constructed such that cleaning and disposal of trapped sediment is made easy, while minimizing interference with discharge activities.
  - Devices should be constructed so that any standing water resulting from the discharge will not cause excessive inconvenience or flooding/damage to adjacent land or structures.
- ✓ The effectiveness of control devices must be monitored during the discharge period and any necessary repairs or modifications made as needed.

OPTIONAL:

- Sediment removal may be enhanced by placing filter fabric, gravel bags, etc. at storm drain inlets.

## Unplanned Discharges

- ✓ Stop the discharge as quickly as possible by turning off water source.
- ✓ Inspect flow path of the discharged water:
  - Control erosion along the flow path.
  - Identify areas that may produce significant sediment or gullies, use sandbags to redirect the flow.
  - Identify erodible areas which may need to be repaired or protected during subsequent repairs or corrective actions
- ✓ If repairs or corrective action will cause additional discharges of water, select the appropriate procedures for erosion control, chlorine residual, turbidity, and chemical additives. Prevent potential pollutants from entering the flow path and ensure that no additional discharged water enters storm drain inlets.

## 2. Sanitary Sewer Maintenance

Applicable to municipalities who own and operated a sewage collection system. Facilities that are covered under this program include sanitary sewer pipes and pump stations owned and operated by the Permittee. The owner of the sanitary sewer facilities is the entity responsible for carrying out this prevention and response program.

## Sewer System Cleaning

- ✓ Sewer lines should be cleaned on a regular basis to remove grease, grit, and other debris that may lead to sewer backups.
- ✓ Establish routine maintenance program. Cleaning should be conducted at an established minimum frequency and more frequently for problem areas such as restaurants that are identified
- ✓ Cleaning activities may require removal of tree roots and other identified obstructions.

---

## Preventative and Corrective Maintenance

- ✓ During routine maintenance and inspection note the condition of sanitary sewer structures and identify areas that need repair or maintenance. Items to note may include the following:
  - cracked/deteriorating pipes
  - leaking joints/seals at manhole
  - frequent line plugs
  - line generally flows at or near capacity
  - suspected infiltration or exfiltration
- ✓ Document suggestions and requests for repair and report the information to the appropriate manager or supervisor.
- ✓ Prioritize repairs based on the nature and severity of the problem. Immediate clearing of blockage or repair is required where an overflow is currently occurring or for urgent problems that may cause an imminent overflow (e.g. pump station failures, sewer line ruptures, sewer line blockages). These repairs may be temporary until scheduled or capital improvements can be completed.
- ✓ Review previous sewer maintenance records to help identify "hot spots" or areas with frequent maintenance problems and locations of potential system failure.

### 3. Spill/Leak/Overflow Control, Response, and Containment

#### Control

*Also see Drainage System procedures sheet*

- ✓ Refer to countywide *Illicit Discharge Detection and Elimination Program*. Components of this program include:
  - Investigation/inspection and follow-up
  - Elimination of illicit discharges and connections
  - Enforcement of ordinances
  - Respond to sewage spills

- Facilitate public reporting of illicit discharges and connections. A citizen's hotline for reporting observed overflow conditions should be established to supplement the field screening efforts being conducted by the Principal Permittee.

## Response and Containment

- ✓ Establish lead department/agency responsible for spill response and containment. Provide coordination within departments.
- ✓ When a spill, leak, and/or overflow occurs, keep sewage from entering the storm drain system to the maximum extent practicable by covering or blocking storm drain inlets or by containing and diverting the sewage away from open channels and other storm drain facilities (using sandbags, inflatable dams, etc.).
- ✓ If a spill reaches the storm drain notify County of Orange Health Care Agency through Control One at (714) 628-7208.
- ✓ Remove the sewage using vacuum equipment or use other measures to divert it back to the sanitary sewer system.
- ✓ Record required information at the spill site.
- ✓ Perform field tests as necessary to determine the source of the spill.
- ✓ Develop additional notification procedures regarding spill reporting as needed.

---

## LIMITATIONS:

Private property access rights needed to perform testing along storm drain right-of-ways. Requirements of municipal ordinance authority for suspected source verification testing necessary for guaranteed rights of entry.

## REFERENCES:

*California Storm Water Best Management Practice Handbooks. Municipal Best Management Practice Handbook. Prepared by Camp Dresser & McKee, Larry Walker Associates, Uribe and Associates, Resources Planning Associates for Stormwater Quality Task Force. March 1993.*

Los Angeles County Stormwater Quality. Public Agency Activities Model Program. On-line:  
[http://ladpw.org/wmd/npdes/public\\_TC.cfm](http://ladpw.org/wmd/npdes/public_TC.cfm)

Santa Clara Valley Urban Runoff Pollution Prevention Program. 1997 Urban Runoff Management Plan. September 1997, updated October 2000.

Santa Clara Valley Urban Runoff Pollution Prevention Program. Water Utility Pollution Prevention Plan.

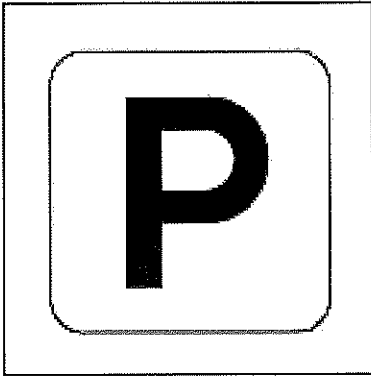

**FF-9**

## **PARKING LOT MAINTENANCE**

**Litter accumulation in parking lots can contribute suspended solids to stormwater runoff; runoff from parking lots may also contain hydrocarbons, oil and grease, and heavy metals to stormwater. Maintaining these areas may involve one or more of the following activities:**

- 1. Sweeping and Cleaning**
- 2. Repair**

### **POLLUTION PREVENTION:**

Pollution prevention measures have been considered and incorporated in the model procedures. Implementation of these measures may be more effective and reduce or eliminate the need to implement other more complicated or costly procedures. Possible pollution prevention measures for parking lot maintenance include:

- Keep accurate maintenance logs to evaluate materials removed and improvements made.
- When repairing parking lots, consider making retrofits that will reduce storm runoff quantities (i.e. permeable surface, directing surface flows to landscaped areas, etc.)
- Once per year, educate municipal staff on pollution prevention measures.
- Educate others about storm water pollution prevention.

### **MODEL PROCEDURES:**

#### **1. Sweeping and Cleaning**

- ✓ Sweep/vacuum all parking lots at least once before the onset of the wet season.
- ✓ When cleaning with water use the procedures below:
  - Block the storm drain or contain runoff.
  - Wash water should be collected and disposed of properly. If wash water does not contain soap or other cleaning agents the water may be discharged to a pervious surface (dirt or landscaped area).

- ✓ Dispose of parking lot sweeping debris and dirt at a landfill.
- ✓ When cleaning heavy oily deposits:
  - Clean oily spots with absorbent materials
  - Do not allow discharges to the storm drain
  - Collect wash water and dispose of properly.
- ✓ Appropriately dispose of spilled materials and absorbents.
- ✓ If cleaning agents are used, select biodegradable products.

OPTIONAL:

- If necessary, establish more frequent sweeping schedule based on usage and field observations of waste accumulation.

## Litter Control

- ✓ Enforce anti-litter laws.
- ✓ Provide an adequate number of litter receptacles.
- ✓ Clean out frequently and/or cover litter receptacles to prevent spillage.
- ✓ Sweep/vacuum all parking lots at least once before the onset of the wet season.

OPTIONAL:

- Post "No Littering" signs.

## 3. Surface Repair

- ✓ Pre-heat, transfer or load hot bituminous material away from storm drain inlets.
- ✓ Apply concrete, asphalt, and seal coat during dry weather to prevent contamination from contacting stormwater runoff.
- ✓ Cover and seal nearby storm drain inlets (with waterproof material or mesh) and manholes before applying seal coat, slurry seal, etc. Leave covers in place until job is complete and until all water from emulsified oil sealants has drained or evaporated. Clean any debris from these covered maintenance holes and drains for proper disposal.
- ✓ Use only as much water as necessary for dust control, to avoid runoff.
- ✓ Catch drips from paving equipment that is not in use with pans or absorbent material placed under the machines. Dispose of collected material and absorbents properly.

## 4. Control Spills

- ✓ If a spill occurs on dirt, excavate and remove the contaminated (stained)

*See Spill Prevention and Control*

procedure sheet

dirt.

- ✓ Store spill response materials at a central location and keep maintenance vehicles adequately supplied.
- ✓ Appropriately dispose of spilled materials and absorbents.

---

## LIMITATIONS:

Limitations related to sweeping activities at large parking facilities may include current sweeper technology to remove oil and grease.

## REFERENCES:

*California Storm Water Best Management Practice Handbooks. Municipal Best Management Practice Handbook. Prepared by Camp Dresser & McKee, Larry Walker Associates, Uribe and Associates, Resources Planning Associates for Stormwater Quality Task Force. March 1993.*

The Stormwater Managers Resource Center (<http://www.stormwatercenter.net/>)

Model Urban Runoff Program: A How-To Guide for Developing Urban Runoff Programs for Small Municipalities. Prepared by City of Monterey, City of Santa Cruz, California Coastal Commission, Monterey Bay National Marine Sanctuary, Association of Monterey Bay Area Governments, Woodward-Clyde, Central Coast Regional Water Quality Control Board. July. 1998.

Oregon Association of Clean Water Agencies. Oregon Municipal Stormwater Toolbox for Maintenance Practices. June 1998.

Santa Clara Valley Urban Runoff Pollution Prevention Program. 1997 Urban Runoff Management Plan. September 1997, updated October 2000.

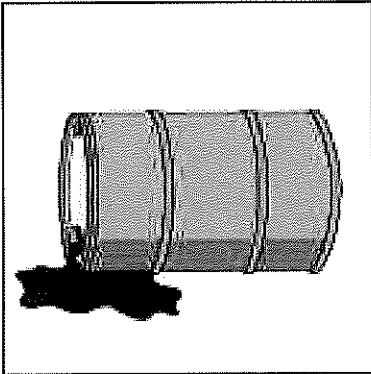

## **SPILL PREVENTION AND CONTROL**

**Preparation for accidental or illegal spills, with proper training and reporting systems implemented, can minimize the discharge of pollutants to the environment. Specific spill prevention and response activities may involve one or more of the following activities:**

- 1. Preparation/Prevention**
- 2. Spill Response**
- 3. Reporting**
- 4. Training**

**An emergency spill response plan, the Orange County Hazardous Materials Area Plan, has been developed. Each City should adopt this plan or an equivalent plan to respond to hazardous materials emergencies.**

### **MODEL PROCEDURES:**

#### **1. Preparation/Prevention**

- ✓ Adopt the Orange County Hazardous Materials Area Plan or equivalent plan which includes a set of planned responses to hazardous materials emergencies, addressing chain-of-command, public agency participation and allocation of authority.
- ✓ Place a stockpile of spill cleanup materials where it will be readily accessible.
- ✓ Develop procedures to prevent/mitigate spills to storm drain systems. Develop and standardize reporting procedures, containment, storage, and disposal activities, documentation, and follow-up procedures.
- ✓ Identify key spill response personnel.

## 2. Spill Response

- ✓ Clean up leaks and spills immediately.
- ✓ On paved surfaces, clean up spills with as little water as possible. Use a rag for small spills, a damp mop for general cleanup, and absorbent material for larger spills. If the spilled material is hazardous, then the used cleanup materials are also hazardous and must be sent to a certified laundry (rags) or disposed of as hazardous waste.
- ✓ Never hose down or bury dry material spills. Sweep up the material and dispose of properly.
- ✓ Use adsorbent materials on small spills rather than hosing down the spill. Remove the adsorbent materials promptly and dispose of properly.
- ✓ For larger spills, a private spill cleanup company or Hazmat team may be necessary.

### OPTIONAL:

- If illegal dumping is observed at the facility post "No Dumping" signs with a phone number for reporting dumping and disposal.

## 3. Reporting

- ✓ Report spills or problems to a city Authorized Inspector

## 4. Training

- ✓ Educate employees about spill prevention and cleanup.

---

### LIMITATIONS:

For hazardous spills, a private spill cleanup company or Hazmat team may be necessary. Proper training is crucial to reducing the frequency, severity, and impacts of leaks and spills.

### REFERENCES:

*California Storm Water Best Management Practice Handbooks. Municipal Best Management Practice Handbook. Prepared by Camp Dresser & McKee, Larry Walker Associates, Uribe and Associates, Resources Planning Associates for Stormwater Quality Task Force. March 1993.*

The Stormwater Mangers Resource Center (<http://www.stormwatercenter.net/>)

Model Urban Runoff Program: A How-To Guide for Developing Urban Runoff Programs for Small Municipalities. Prepared by City of Monterey, City of Santa Cruz, California Coastal Commission, Monterey Bay National Marine

# FF-10

Sanctuary, Association of Monterey Bay Area Governments, Woodward-Clyde, Central Coast Regional Water Quality Control Board. July. 1998.

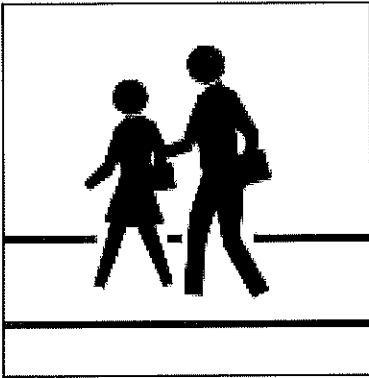

## **SIDEWALK, PLAZA, AND FOUNTAIN MAINTENANCE AND CLEANING**

**Pollutants on sidewalks and other pedestrian traffic areas and plazas are typically due to littering and vehicle use. Fountain water containing chlorine and copper-based algacides is toxic to aquatic life. Proper inspection, cleaning, and repair of pedestrian areas and city surfaces and structures can reduce pollutant runoff from these areas. Maintaining these areas may involve one or more of the following activities:**

- 1. Surface Cleaning**
- 2. Graffiti Cleaning**
- 3. Sidewalk Repair**
- 4. Controlling Litter**
- 5. Fountain Maintenance**

### **POLLUTION PREVENTION:**

Pollution prevention measures have been considered and incorporated in the model procedures. Implementation of these measures may be more effective and reduce or eliminate the need to implement other more complicated or costly procedures. Possible pollution prevention measures for sidewalk, plaza, and fountain maintenance and cleaning include:

- Use dry cleaning methods whenever practical for surface cleaning activities.
- Use the least toxic materials available (e.g. water based paints, gels or sprays for graffiti removal).
- Once per year, educate municipal staff on pollution prevention measures.

### **MODEL PROCEDURES:**

#### **1. Surface Cleaning**

**Discharges of wash water to the storm water drainage system from cleaning or hosing of impervious surfaces is prohibited.**

## Sidewalks, Plazas

- ✓ Use dry methods (e.g. sweeping, backpack blowers, vacuuming) whenever practical to clean sidewalks and plazas rather than hosing, pressure washing, or steam cleaning. DO NOT sweep or blow material into curb; use devices that contain the materials.
- ✓ If water must be used, block storm drain inlets and contain runoff. Discharge wash water to landscaping or contain and dispose of properly.

## Parking Areas, Driveways, Drive-thru

- ✓ Parking facilities should be swept/vacuumed on a regular basis. Establish frequency of public parking lot sweeping based on usage and field observations of waste accumulation.
- ✓ If water must be used, block storm drain inlets and contain runoff. Discharge wash water to landscaping or contain and dispose of properly.
- ✓ Sweep all parking lots at least once before the onset of the wet season.
- ✓ Use absorbents to pick up oil; then dry sweep.
- ✓ Appropriately dispose of spilled materials and absorbents.

### OPTIONAL:

- Consider increasing sweeping frequency based on factors such as traffic volume, land use, field observations of sediment and trash accumulation, proximity to water courses, etc.

## Building Surfaces, Decks, etc., without loose paint

- ✓ Use high-pressure water, no soap.
- ✓ If water must be used, block storm drain inlets and contain runoff. Discharge wash water to landscaping or contain and dispose of properly.

## Unpainted Building Surfaces, Wood Decks, etc.

- ✓ If water must be used, block storm drain inlets and contain runoff. Discharge wash water to landscaping or contain and dispose of properly.
- ✓ Use a biodegradable cleaning agent or acid wash to remove deposits, wood restorer, or other chemicals. Screen wash water using an appropriate filtering device (e.g. filter fabric), if needed, to catch debris.
- ✓ Make sure pH is between 6.5 and 8.5 THEN discharge to landscaping (if cold water without a cleaning agent) otherwise dispose of properly.

## 2. Graffiti Cleaning

### Graffiti Removal

*See Roads, Streets, and Highways Operation and Maintenance procedure sheet.*

- ✓ Avoid graffiti abatement activities during rain events.
- ✓ When graffiti is removed by painting over, implement the procedures under Painting and Paint Removal in the *Roads, Streets, and Highway Operation and Maintenance* procedure sheet.

- ✓ Protect nearby storm drain inlets prior to removing graffiti from walls, signs, sidewalks, or other structures needing graffiti abatement. Clean up afterwards by sweeping or vacuuming thoroughly, and/or by using absorbent and properly disposing of the absorbent.
- ✓ Note that care should be taken when disposing of waste since it may need to be disposed of as hazardous waste.

OPTIONAL:

- Consider using a waterless and non-toxic chemical cleaning method for graffiti removal (e.g. gels or spray compounds).

## 3. Sidewalk Repair

### Surface Removal and Repair

*Also see the street sweeping section of the Roads, Streets, and Highways Operation and Maintenance procedure sheet.*

- ✓ Schedule surface removal activities for dry weather if possible.
- ✓ Avoid creating excess dust when breaking asphalt or concrete.
- ✓ Take measures to protect nearby storm drain inlets prior to breaking up asphalt or concrete (e.g. place hay bales or sand bags around inlets). Clean afterwards by sweeping up material.
- ✓ Designate an area for clean up and proper disposal of excess materials.
- ✓ Remove and recycle as much of the broken pavement as possible.
- ✓ When making saw cuts in pavement, use as little water as possible. Cover each storm drain inlet with filter fabric during the sawing operation and contain the slurry by placing straw bales, sandbags, or gravel dams around the inlets. After the liquid drains shovel or vacuum the slurry, remove from site and dispose of properly.
- ✓ Always dry sweep first to clean up tracked dirt. Use a street sweeper or vacuum truck. Do not dump vacuumed liquid in storm drains. Once dry sweeping is complete, the area may be hosed down if needed. Discharge wash water to landscaping, pump to the sanitary sewer if permitted to do so or contain and dispose of properly.

### Concrete Installation and Repair

*See Roads, Streets, and Highways Operation and Maintenance procedure sheet.*

- ✓ Avoid mixing excess amounts of fresh concrete or cement mortar on-site. Only mix what is needed for the job.
- ✓ Wash concrete trucks off-site or in designated areas on-site, such that there is no discharge of concrete wash water into storm drain inlets, open ditches, streets, or other storm water conveyance structures.
- ✓ Store dry and wet concrete materials under cover, protected from rainfall and runoff and away from drainage areas. After job is complete remove temporary stockpiles (asphalt materials, sand, etc.) and other materials as soon as possible.
- ✓ Return leftover materials to the transit mixer. Dispose of small amounts of

excess concrete, grout, and mortar in the trash.

- ✓ When washing concrete to remove fine particles and expose the aggregate, contain the wash water for proper disposal.
- ✓ Do not wash sweepings from exposed aggregate concrete into the street or storm drain. Collect and return sweepings to aggregate base stock pile, or dispose in the trash.
- ✓ Protect applications of fresh concrete from rainfall and runoff until the material has hardened.

## 4. Litter Control

- ✓ Enforce anti-litter laws.
- ✓ Provide litter receptacles in busy, high pedestrian traffic areas of the community, at recreational facilities, and at community events.
- ✓ Cover litter receptacles and clean out frequently to prevent leaking/spillage or overflow.

### OPTIONAL:

- Post "No Littering" signs.

## 5. Fountain Maintenance

- ✓ Do not use copper-based algaecides. Control algae with chlorine or other alternatives, such as sodium bromide.
- ✓ When draining fountains, never discharge water to a street or storm drain; discharge to the sanitary sewer
- ✓ Allow chlorine to dissipate for a few days and then recycle/reuse water by draining it gradually onto a landscaped area. Water must be tested prior to discharge to ensure that chlorine is not present (concentration must be less than 0.1 ppm).

---

### LIMITATIONS:

Surface cleaning activities that require discharges to the local sanitation agency will require coordination with the agency.

### REFERENCES:

Bay Area Stormwater Management Agencies Association. 1996. Pollution From Surface Cleaning.

*Model Urban Runoff Program: A How-To Guide for Developing Urban Runoff Programs for Small Municipalities. Prepared by City of Monterey, City of Santa Cruz, California Coastal Commission, Monterey Bay National Marine Sanctuary, Association of Monterey Bay Area Governments, Woodward-Clyde, Central Coast Regional Water Quality*

*Control Board. July. 1998.*

Oregon Association of Clean Water Agencies. Oregon Municipal Stormwater Toolbox for Maintenance Practices. June 1998.

San Diego Stormwater Co-permittees Jurisdictional Urban Runoff Management Plan. 2001. Municipal Activities Model Program Guidance. November.

Santa Clara Valley Urban Runoff Pollution Prevention Program. 1997 Urban Runoff Management Plan. September 1997, updated October 2000.

Santa Clara Valley Urban Runoff Pollution Prevention Program. Maintenance Best Management Practices for the Construction Industry. Brochures: Landscaping, Gardening, and Pool; Roadwork and Paving; and Fresh Concrete and Mortar Application. June 2001.

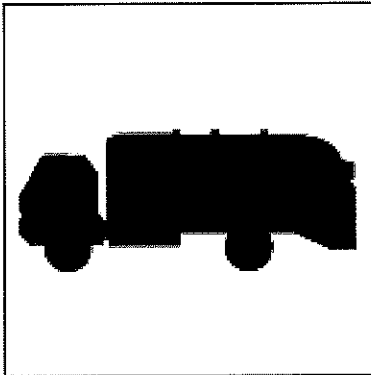

## SOLID WASTE HANDLING

It is important to control litter to eliminate trash and other materials in storm water runoff. Waste reduction is a major component of waste management and should be encouraged through training and public outreach. Management of waste once it is collected may involve reuse, recycling, or proper disposal. Specific solid waste handling activities may include one or more of the following:

1. Solid Waste Collection
2. Waste Reduction and Recycling
3. Hazardous Waste Collection
4. Litter Control

**Reduce** by purchasing only the amount needed.  
**Reuse** products when possible.  
**Recycle** leftover products that are recyclable, and dispose of other wastes safely.

### POLLUTION PREVENTION:

Pollution prevention measures have been considered and incorporated in the model procedures. Implementation of these measures may be more effective and reduce or eliminate the need to implement other more complicated or costly procedures. Possible pollution prevention measures for solid waste handling include:

- Reuse products when possible.
- Recycle leftover products that are recyclable.
- Once per year, educate municipal staff on pollution prevention measures.

### MODEL PROCEDURES:

#### 1. Solid Waste Collection

- ✓ Implement procedures, where applicable, to collect, transport, and dispose of solid waste at appropriate disposal facilities in accordance with applicable federal, state, and local laws and regulations. Optional disposal options include the reuse and recycling of appropriate materials (see following sections).

- ✓ Include properly designed trash storage areas.
- ✓ Regularly inspect solid waste containers for structural damage. Repair or replace damaged containers as necessary.
- ✓ Secure solid waste containers; containers must be closed tightly when not in use.
- ✓ Do not fill waste containers with washout water or any other liquid.
- ✓ Remove all debris from containers prior to cleaning with water. Only clean out containers in a designated area that drains to a washrack that is connected to a sanitary sewer.
- ✓ Minimize spillage/leaking from solid waste containers. For larger solid waste containers (especially compactors) that utilize a hydraulic fluid pump system, regularly inspect and replace faulty pumps or hoses to minimize the potential of releases and spills.
- ✓ Ensure that only appropriate solid wastes are disposed of. Certain wastes such as hazardous wastes, appliances, fluorescent bulbs, pesticides, etc. may not be disposed of in solid waste containers.

*Also see Emergency Spill Response procedure sheet.*

## 2. Waste Reduction and Recycling

**Although many types of waste can be recycled, recycling options for each waste type may be limited. All gasoline, antifreeze, waste oil, and lead-acid batteries can be recycled. Latex and oil-based paint can be reused, as well as recycled. Materials that cannot be reused or recycled should be disposed of properly.**

- ✓ Provide containers for the collection and storage of recyclable materials.
- ✓ Do not mix liquid wastes, this can cause chemical reactions or make recycling impossible and complicate disposal.
- ✓ Recycle used motor oil. Municipalities are required to have a used oil recycling element within their integrated waste management plan.

*CalRecycle has a Recycling Hotline, (800) RECYCLE, that provides information and recycling locations for used oil.*

## 3. Hazardous Waste Collection

Household hazardous wastes (HHW) are defined as waste materials which are typically found in homes or similar sources, which exhibit characteristics such as: corrosivity, ignitability, reactivity, and/or toxicity, or are listed as hazardous materials by EPA.

**List of most common HHW products:**

Drain opener  
 Oven cleaners  
 Wood and metal cleaners and polishes  
 Paint Thinners  
 Automotive oil and fuel additives  
 Adhesives  
 Grease and rust solvents Batteries  
 Herbicides  
 Paint strippers and removers Pesticides  
 Fungicides/wood preservatives  
 Starter fluids  
 Carburetor and fuel injection cleaners

✓ Follow proper storage and disposal measures for hazardous waste materials as identified on packaging or Material Safety Data Sheets.

✓ Emergencies related to hazardous waste should be reported to 911

OPTIONAL:

- Identify and promote use of non-hazardous alternatives.
- Promote household hazardous waste (HHW) reuse and recycling.

## 4. Litter Control

✓ Enforce anti-litter laws.

✓ Provide litter receptacles in busy, high pedestrian traffic areas of the community, at recreational facilities, and at community events.

✓ Clean out and cover litter receptacles frequently to prevent overflow.

✓ Increase litter control for events generating substantial quantities of litter.

OPTIONAL:

- Post "No Littering" signs
- Place trash receptacles at transit stops and maintain as necessary.
- Participate in and/or organize additional clean-up programs (e.g., "Coastal Clean Up Day", "Pride Days", "Volunteer Connection Days").

## REFERENCES:

Bay Area Stormwater Management Agencies Association. 1996. *Pollution From Surface Cleaning*.

*California Storm Water Best Management Practice Handbooks. Municipal Best Management Practice Handbook.* Prepared by Camp Dresser & McKee, Larry Walker Associates, Uribe and Associates, Resources Planning Associates for Stormwater Quality Task Force. March 1993.

Environmental Protection Agency (EPA). *Pollution Prevention and Good Housekeeping for Municipal Operations Storm Water. Pet Waste Collection.* Office of Wastewater Management. Online:

# FP-5

[http://www.epa.gov/npdes/menuofbmps/poll\\_3.htm](http://www.epa.gov/npdes/menuofbmps/poll_3.htm)

Harvard University. 2002. Solid Waste Container Best Management Practices – Fact Sheet On-Line Resources – Environmental Health and Safety.

COUNTY OF ORANGE  
PUBLIC FACILITIES & RESOURCES DEPARTMENT

**MANAGEMENT GUIDELINES  
FOR THE USE OF FERTILIZERS AND PESTICIDES**

September 2000  
(Revision to March 1993)

VICKI L. WILSON  
Director

ORANGE COUNTY BOARD OF SUPERVISORS

CHARLES V. SMITH  
First District

JAMES W. SILVA  
Second District

TODD SPITZER  
Third District

CYNTHIA P. COAD  
Fourth District

THOMAS W. WILSON  
Fifth District

## TABLE OF CONTENTS

Glossary

Executive Summary

### 1.0 Introduction

- 1.1 Status of Fertilizer and Pesticide Use
- 1.2 Management Options
- 1.3 Definitions

### 2.0 Fertilizer Management

- 2.1 Identification and Scope of Guidelines
- 2.2 General Considerations
  - 2.2.1 State and Federal Law
  - 2.2.2 General Recommendations
- 2.3 Planning for the Use of Fertilizers
  - 2.3.1 Soil Testing
  - 2.3.2 Application Rates
  - 2.3.3 Timing
- 2.4 Application Methods
  - 2.4.1 Banding of Fertilizer
  - 2.4.2 Foliar Fertilization
  - 2.4.3 Broadcast Application
  - 2.4.4 Fertigation
- 2.5 Storage and Handling of Fertilizers
  - 2.5.1 General Description
  - 2.5.2 Dry Fertilizer
  - 2.5.3 Liquid Fertilizer

### 3.0 Pesticide Management

- 3.1 Identification and Scope of Guidelines
- 3.2 General Considerations
  - 3.2.1 State and Federal Law
  - 3.2.2 Chemical Labels and Materials Safety Data Sheets (MSDS)
  - 3.2.3 General Recommendations
- 3.3 Planning for the Use of Pesticides
  - 3.3.1 Selection of Appropriate Pesticides
  - 3.3.2 Certification, Licensing and Permitting
  - 3.3.3 Employee Training
  - 3.3.4 Accident Mitigation
  - 3.3.5 Emergency Medical Care
  - 3.3.6 Equipment and Equipment Maintenance
  - 3.3.7 Groundwater and Surface Water Protection

## **TABLE OF CONTENTS (cont'd)**

- 3.4 Application of Pesticides
  - 3.4.1 Supervision
  - 3.4.2 Proper Techniques
  - 3.4.3 User Safety and Protection
  
- 3.5 Storage, Disposal and Transportation
  - 3.5.1 Proper Storage
  - 3.5.2 Proper Disposal
  - 3.5.3 Safe Transportation Methods
  
- 4.0 Integrated Pest Management
  - 4.1 Background of IPM
  - 4.2 Scope of Guidelines
  - 4.3 Alternatives to Pesticides

## **REFERENCES**

## GLOSSARY

### **California Code of Regulations, Title 3, Division 6 (3 CCR)**

The State of California Code regulating pesticides and pest control operations.

### **California Fertilizer Association (CFA)**

An organization promoting progress in the fertilizer industry in the interest of an efficient and profitable agricultural community. Activities of CFA include developing and disseminating new information to its members and others; supporting production-oriented research programs to identify maximum yield systems for farmers; promoting ergonomic topics at our schools, colleges and universities; and maintaining open communications among the industry, universities and other state and federal agencies.

### **Chemical Labels**

As required by federal law, manufacturers of pesticides must provide chemical labels on the containers of all pesticides distributed. These labels include all necessary information on the chemical constituents of the pesticide, including recommendations and instructions for use, toxicity classification and the appropriate warning statements and emergency procedures in case of acute exposures. As required by state law, labels must be kept in good, readable condition and be attached to all pesticide containers at all times.

### **Drainage Area Management Plan (DAMP)**

A document required under the municipal NPDES stormwater permits issued to the co-permittees by Santa Ana and San Diego Regional Water Quality Control Boards.

### **Equivalent Training**

A term referring to public agency employees dealing with the application of pesticides who have not received a qualified applicator's license (QAL) from the State of California, but who has completed a training course in pesticide application offered by the County of Orange.

### **Eutrophication**

A decrease in dissolved oxygen in a body of water to such an extreme extent that plant life is favored over animal life. For example, a lake that is overgrown in algae on the surface is likely in a state of eutrophication.

### **Integrated Pest Management**

The trend in vegetation management that supports moving away from reliance on pesticides and toward an integrated approach of limited pesticide use with more environmentally friendly pest control techniques.

### **Maximum Extent Practicable (MEP)**

MEP means taking into account equitable considerations of competing factors, including, but not limited to, the gravity of the problem, fiscal feasibility, public health risks, societal concern and social benefit.

## **GLOSSARY (cont'd)**

### **Materials Data Safety Sheet (MSDS)**

Similar to chemical labels and also required by federal law, these sheets should contain all information necessary for the safe handling of pesticides. They include chemical identifications, hazardous ingredients, physical data, fire and explosion data, health hazards, reactivity data, spill or leak cleanup procedures, special protection and special precautions.

### **National Pollutant Discharge Elimination System (NPDES)**

The national program under the Clean Water Act for controlling discharges from point sources directly into Waters of the United States.

### **Permittee**

A permittee to an NPDES permit that is responsible for permit conditions relating to the discharge for which it is operator. As used in the Stormwater Permit Implementation Agreement, permittees are the County of Orange, the 33 cities of Orange County and the Orange County Flood Control District.

### **Pest Control Advisor (PCA)**

Certification obtained from the State of California after demonstrating adequate knowledge of pests, pesticides and the implications of pesticide use. A recommendation for pesticide use must be obtained from a PCA before public agencies may approve any pesticide applications.

### **Qualified Applicator's License (QAL)**

A license obtained from the State of California after demonstrating adequate knowledge of the proper techniques for handling, storing, transporting and applying pesticides. Workers must obtain a QAL before being permitted to apply or supervise application of Category 1 pesticides.

### **Qualified Fertilizer Specialist**

A person designated by the governing public agency who is knowledgeable of the proper techniques for handling, storing, transporting and applying fertilizers as defined in the Management Guidelines for Use of Fertilizers and Pesticides. This person shall be able to sample, inspect, test and make analyses of fertilizers that are in use or being considered for use in the agency's jurisdiction to such an extent to adequately determine their compliance with the management guidelines.

### **Restricted Materials Permit**

A permit that must be acquired by any public agency before application of the pesticides listed as restricted by the State of California in the Code of Regulations ("CCR"), Title 3, Division 6. In Orange County, this permit must be obtained from the County Agricultural Commissioner.

## **GLOSSARY (cont'd)**

### **State Code**

In this report, referring to CCR, Title 3, Division 6, and noted as "3 CCR."

### **Storm Drain**

Pipe or channel structure designed to convey only stormwater runoff for purposes of flood protection. Federal regulations use the term "storm sewer." Use of the word "sewer" for a stormwater conveyance structure should be discouraged, since the word "sewer" also includes sanitary sewers and combined sewers which carry human waste.

### **Toxicity Classification**

The California Department of Food and Agriculture groups pesticides into three categories according to their toxicity or potential to cause injury to people. Category 1 pesticides are the most hazardous and their use is normally restricted, while Category 3 pesticides are the least toxic to people and are generally less hazardous.

## EXECUTIVE SUMMARY

This document was prepared to establish guidelines for the management of fertilizers and pesticides. The main objective of these guidelines is to safeguard to "the maximum extent practicable"\* against unnecessary discharges of fertilizers and pesticides into surface and groundwater systems and to establish safe and reasonable standards for handling those materials. The guidelines are based on state and federal laws, environmental policies and "best management practices" established by various public and private agencies. Through this document, it is envisaged that these practices will establish a set of uniform standards and procedures.

## **1.0 INTRODUCTION**

### **1.1 Status of Fertilizer and Pesticide Use**

Fertilizers and pesticides are a primary tool of vegetation management. Used properly, fertilizers provide important nutrient supplies for vegetation and agriculture, and pesticides help to protect those resources from potential harm.

Used improperly, fertilizers and pesticides can become an impairment to surface and groundwater supplies. Careless application, mixing, transportation, storage and disposal allow chemicals to enter surface and groundwater through runoff and infiltration; the same handling problems endanger human health through exposure to toxic chemicals; soil degradation often results from overuse and misuse of pesticides and fertilizers. Even under ideal conditions, there is still a high level of risk, and consequently, there is a need for considerable professional planning and management.

### **1.2 Management Options**

Because of the risk involved in using fertilizers and pesticides, the development of management guidelines for use of fertilizers and pesticides is an essential element of the DAMP. These guidelines are designed not only to comply with the NPDES Stormwater Program, but also to minimize any threat to human health and environmental resources from improper use of fertilizers and pesticides. It is envisaged that consideration of these guidelines by the permittees will cause public agencies to re-evaluate their approach to using fertilizers and pesticides and move toward reducing dependence on them.

The guidelines that follow are intended for the use of the Permittees, although they may ultimately be used on a broader scale. They are based on the laws, management guidelines and "best management practices" established by other federal, state and local agencies. They recognize that the safe management of fertilizers and pesticides is a shared responsibility between the field worker and management. These guidelines address the concern for fertilizer and pesticide use at a basic level, and if followed, they should reasonably prevent environmental damage to the highest degree possible.

### **1.3 Definitions**

For the purpose of these guidelines, fertilizers may be referred to as "nutrients" or "soil nutrients," and the term "pesticides" will encompass all herbicides, insecticides, fungicides and rodenticides. The California Food and Agricultural Code and the California Code of Regulations, Title 3 (3 CCR)\*, constitute the laws and regulations referenced in this plan. They are referenced often and usually referred to as the "State Code."\* Also, Permittees will be referred to as "public agencies," and employees working for these public agencies who handle fertilizers & pesticides will be referred to as "workers" or "public employees."

## **2.0 FERTILIZER MANAGEMENT**

### **2.1 Definition and Scope of Guidelines**

Fertilizers are nutrients applied to soil to provide a better growing environment for plants. The fertilizers most commonly in use in Southern California today are nitrogen- and phosphorus-based. Both leach into soils easily in the presence of water and have become a water quality concern, causing algal blooms and eutrophication\* and, in some cases, causing levels to exceed federal drinking water standards.

However, fertilizers also play the important role of promoting vegetation growth that protects soil from erosion and enhances landscape aesthetics. Because there is a necessity for soil nutrients and because there is a potential for adverse effects on local waterways due to the loss of these nutrients through runoff and infiltration, management guidelines are necessary as a means of reducing the loss of fertilizers into water supplies.

### **2.2 General Considerations**

#### 2.2.1 State and Federal Law

Because most fertilizers are not as toxic as pesticides, state and federal lawmakers have not developed regulations for their use. Fertilizers are not usually considered an immediate danger to public health or safety. However, the California Fertilizer Association (CFA)\*, a Sacramento-based organization, has developed complete management guidelines for fertilizer use and the State Department of Food and Agriculture has recommendations for use of nitrate-based fertilizers, both of which are available for consultation.

#### 2.2.2 General Recommendations

1. Public agencies should periodically have soils tested before applying fertilizers to be certain that application is appropriate for and compatible with soil conditions. The samples should be analyzed by a qualified specialist for fertilizer applications\*, and workers should follow the recommendations.
2. Public agencies should choose to use organic fertilizers such as compost, peat and mulch wherever possible to increase soil porosity and water retention.
3. Workers should apply only the minimum amount of fertilizer needed and incorporate it directly into the soil around the plant, where possible, to minimize potential surface runoff.
4. Workers should not apply fertilizers in the rain or on the same day that rain is expected.
5. Workers should immediately cleanup any spill of fertilizers.

6. Storage facilities should be covered and have impermeable foundations so that potential spills don't have the opportunity to runoff into surface water or leach into groundwater systems.
7. Fertilizers that may be carried by the wind should be stored in areas away from open loading spaces and entrances of storage warehouses.
8. Fertilizers should be securely covered in the vehicle before being taken to application sites so that none can spill or fly out during transport.
9. Use slow release fertilizers -- such as water soluble nitrogen fertilizers, coated fertilizers and fertilizers of limited solubility -- whenever possible to minimize the possibility of leaching.

### **2.3 Planning for Use of Fertilizers**

#### 2.3.1 Soil Testing

Most fertilizers travel quickly through water. Therefore, fertilizers will leach through soil and potentially contaminate groundwater more quickly after excess watering or irrigation, after heavy rains and where the water table is high. For this reason, soil testing is an important management technique to determine the safest fertilizer application rate.

The California Landscape Contractors Association (CLCA) has a complete list of organizations in Southern California that offer soil testing and analyzing for fertilizer use. To get a copy of that list, CLCA can be contacted at (916) 448-2522. If a reliable soil analyst is not already known, it is advisable for public agencies to consult CLCA and research a specialist who can make recommendations for fertilizer use.

#### 2.3.2 Application Rates

The amount of fertilizer needed for different applications depends on a number of factors. For specific recommendations, a qualified specialist should be consulted. The following are some factors to be considered:

- The vegetation's ability to use fertilizer;
- The amount of nutrients already in the soil, including fertilizer that may still be present from a previous application;
- The amount of soil nutrients that will or can be obtained from natural processes;
- The expected loss of nutrients from the soil; and
- The temperature at the time of application.

### 2.3.3 Timing

For vegetation with different growth patterns, fertilizers should be applied at different times and in different quantities. The vegetation being managed should be researched and fertilizers applied only according to the amounts and at the time intervals recommended by a qualified specialist for fertilizer applications. This should minimize the waste of fertilizer and reduce any risk of water contamination.

## **2.4 Application Methods of Fertilizers**

This section details the most common methods for application of fertilizers. These are not the only acceptable methods of fertilizer application. Every application has its own circumstances and variables to consider. A qualified fertilizer specialist should be consulted to recommend the most appropriate application method.

### 2.4.1 Banding of Fertilizer

Probably the most common and safest application method, this involves physically working small amounts of fertilizer into the soil in a band beneath and around the sides of a seed. It allows new roots to efficiently use the nutrients and minimizes potential nutrient loss to surface runoff. However, given the labor involved, banding may not be practical for most public agency fertilizer applications.

### 2.4.2 Foliar Fertilization

This is fertilizer applied in solution form that is absorbed through leaves and stems. The method can reduce nutrient leaching into the soil when applied correctly and can be performed at the same time as pesticides application to avoid spraying twice. In this case, the guidelines for pesticide applications must also apply.

### 2.4.3 Broadcast Application

By this method, dry or liquid fertilizer is uniformly spread over the soil surface. This is often done mechanically, an example being the "drop spreader" which is usually an inverted triangle hopper. The simplest of mechanical applicators, the drop spreader is commonly mounted on wheels and pushed by hand or pulled by vehicle to drop fertilizer out of the bottom of the triangle.

Other types of broadcast applicators include spray booms for liquid fertilization or "spinning disks" mounted on a moving vehicle that throw dry fertilizer into the air. It should be noted that these latter methods do not offer much control over fertilizer drift in adverse weather conditions.

#### 2.4.4 Fertigation

Although not likely to be used by public agencies for fertilizer applications, this method is common among Californian farmers who incorporate fertilizers into irrigation water. The potential for nutrient leaching using this method, though, appears to be high.

### **2.5 Storage and Handling of Fertilizers**

#### 2.5.1 General Description

When stored and handled properly, fertilizers present no hazard to the users' health. Public employees responsible for the storage and handling of fertilizers should be aware that some fertilizers have properties that can result in dangerous chemical reactions if mixed with other substances or under unusual circumstances. For example, ammonium nitrate may become explosive if it becomes mixed in diesel fuel; a dehumidifier may be necessary for storage areas where sensitive fertilizers are stored. Also, because most fertilizers tend to be corrosive, concrete structures are preferred for fertilizer storage facilities.

#### 2.5.2 Dry Fertilizer

In most cases, dry fertilizers are safe to store, transport and handle. However, because some fertilizers have unique, potentially dangerous properties, it is advisable for public agencies to consult a qualified fertilizer specialist for the safest storage and handling procedures for specific fertilizers.

#### 2.5.3 Liquid Fertilizer

Fertilizers in liquid form are potentially more hazardous than dry fertilizer. Public employees responsible for storage and handling need to be aware of the specific properties of each liquid fertilizer in use, including corrosivity and tolerable temperature and pressure ranges. Protective equipment may be necessary for workers handling fertilizers such as sulfuric or phosphoric acid. A qualified fertilizer specialist should be consulted for recommending the safest handling and storage procedures for specific liquid fertilizers.

## **3.0 PESTICIDE MANAGEMENT**

### **3.1 Definition and Scope of Guidelines**

Pesticides are designed to kill or restrict the growth of plants and organisms, and thus, are potentially dangerous chemicals. Increasing scientific concern for their safe use and heightened public awareness of health concerns has led to more and more regulations in the United States at both the state and federal level. Pesticide use by public agencies often involves applications to keep flood control channels and roadways clear or to minimize health and safety hazards of disease-bearing rodents and insects. Any of these applications can drain into stormwater basins if not controlled properly. Although safety concerns and the cost of complying with new regulations have encouraged some public agencies to cut back on the use of pesticides, use is still common, and their management is therefore essential.

### **3.2 General Considerations**

#### 3.2.1 State and Federal Law

The California Department of Food and Agriculture and the federal Toxic Substances Control Act (TSCA) have set forth extensive rules and regulations that must be met by all public agencies. At an absolute minimum, public agencies must comply with these laws or be subject to the penalties described in the statutes.

#### 3.2.2 Chemical Labels and Materials Safety Data Sheets (MSDS)

1. Without exception, chemical labels\* provided by the manufacturer of each pesticide are the first source of recommendations and instructions for chemical use. Whenever a chemical is to be used by a worker or a contractor of a public agency, the user needs to be intimately familiar with the label instructions and requirements.

As described in the State Code (Ch. 2, Subch. 1, Art. 10), the label must appear on the immediate container of the chemical and include, in prominent, bold type, the appropriate warning or caution statement according to its toxicity classification\*. If a chemical is transferred to another container, a copy of the label should be transferred with it.

Workers should never handle a container that doesn't have a warning label attached, and the supervisor in charge should be immediately advised of the situation. If a label is badly damaged, the supervisor should replace it.

2. Workers using pesticides should have readily available the Materials Safety Data Sheets (MSDS)\* for each chemical they are using. Although the MSDS is a form that may vary in appearance for different chemicals, the information is the same, as required by law. Similar to the chemical labels, these sheets contain information necessary to handle each chemical safely, and all workers should be familiar with the information.

MSDS sheets include chemical identifications, hazardous ingredients, physical data, fire and explosion data, health hazards, reactivity data, spill or leak cleanup procedures, special protection and special precautions.

### 3.2.3 General Recommendations

1. Public agencies should maintain a complete list of all chemicals and their uses.
2. Public agencies should thoroughly investigate and consider all alternatives to pesticide use.
3. Workers should use pesticides only according to label instructions.
4. Work crews should bring to the work site only the amount of chemical to be used during the application and use only the minimum amount the chemical necessary.
5. Workers should consider weather conditions that could affect application (for example, they shouldn't spray when winds are exceeding 5 mph, when raining or when rain is likely).
6. Workers should consider area drainage patterns (for example, they shouldn't apply near wetlands, streams and lakes or ponds unless it is for an approved maintenance activity).
7. Workers should consider soil conditions before applying pesticides (for example, they shouldn't apply to bare or eroded ground).
8. Workers should triple-rinse empty pesticide containers before disposal and use the leftover wash as spray.
9. Workers should never clean or rinse pesticide equipment and containers in the vicinity of storm drains\*.
10. Pesticides should only be stored in areas with cement floors and in areas insulated from temperature extremes.
11. Workers should secure chemicals and equipment during transportation to prevent tipping or excess jarring in part of the vehicle completely isolated from people, food and clothing.

12. Workers or their supervisors should inspect pesticide equipment, storage containers and transportation vehicles daily.
13. Public agencies should adopt a plan for dealing with potential accidents before they happen.
14. Workers should immediately clean up any chemical spill according to label instructions and notify the appropriate supervisors and agencies.

### **3.3 Planning for Use of Pesticides**

#### 3.3.1 Selection of Appropriate Pesticides

1. Pesticides are to be used only after recommendation from a state-licensed or certified pest control advisor.
2. Public agencies should also seek advice for appropriate pesticide use from the Orange County Agricultural Commission, from other professional pesticide handlers and/or through professional publications. The County Agricultural Commission can be contacted at (714) 447-7100.
3. A special effort should be made to limit use of restricted pesticides and all other Category One pesticides.

#### 3.3.2 Certification, Licensing and Permitting

1. Pesticides are only to be applied by or under the direct supervision of an individual with a qualified applicators license (QAL)\* for pesticide applications or by workers with equivalent training\*.
2. Chemicals listed as "restricted" in the State of California may be used only under a restricted materials permit\* (StateCode Ch. 2, Subch. 4) to be issued by the Orange County Agricultural Commission. The permit must be renewed annually for continued use. For more information, contact the Commission at (714) 447-7100.
3. All other guidelines concerning permits, licensing and certification requirements to be followed before pesticide application are detailed in the State Code, Chapter 3, Subchapter 1.

### 3.3.3 Employee Training

1. Public agency employees must know the information on the chemical label and its MSDS before using pesticides in any capacity. In addition, they should (a) know the immediate and long-term health hazards posed by chemicals to be used, the common symptoms of chemical poisoning and the ways poisoning could occur, and (b) know the safe work practices to be followed, including the appropriate protective clothing, equipment, mixing, transportation, storage, disposal and spill cleanup procedures that apply to the specific chemicals being used.
2. In addition to the training and annual continuing education required for licensing and certification (3 CCR, Ch. 3, Subch.3, Art. 2), public employees are encouraged to participate in continuing pesticide education programs whenever the programs are available.

### 3.3.4 Accident Mitigation

Public agencies using pesticides should have plans for dealing with potential accidents before they happen. These plans should consider:

1. Labels and MSDS Sheets -- All workers handling pesticides must be familiar with these instructions. The steps for accident mitigation are spelled out on chemical labels and MSDS sheets.
2. Spill Cleanup Kits -- Any time pesticides are being handled, there should be a cleanup kit on hand in case of an accident. This means there should always be a cleanup kit located in pesticide storage areas, on vehicles used to transport pesticides and on location where the chemicals are being applied. Although these kits may vary in what they contain depending on the chemical type and the situation, at a minimum they should include:
  - spill-control procedures
  - a five gallon drum with sealable lid
  - a dust pan and broom
  - a squeegee
  - a shovel
  - protective goggles, gloves, boots, coveralls
  - a tarp (for covering dry spills)
  - detergent and water (check label or MSDS for proper use)
  - barricade tape, florescent traffic safety cones or string to cordon off an area
  - large sponges, containment booms or some other absorbent material

3. Cleanup Procedures -- Spilled pesticides must be prevented from entering the local surface and/or groundwater supplies. Specific recommendations for spill cleanup should be available on each chemical label or MSDS. Specific recommendations for the sequence of procedures may also vary depending on the situation. However, generally, in case of a spill, the responsible worker(s) should:

**EVALUATE** the accident and quickly determine the most immediate concerns (medical and/or environmental).

**CONTAIN OR CONTROL** the spill.

**NOTIFY** the supervisor in charge who should, in turn, notify the proper authorities. If contact cannot be made, dial 911.

**ISOLATE** the area with fluorescent traffic safety cones, ropes or some other cordoning device to be sure that no one walks, wanders or drives through the spill area.

**CLEAN UP** the spill as best as possible following label instructions and using the appropriate spill cleanup kit.

**EVALUATE** any damage that may have occurred resulting from the spill (property damage, health damage, equipment damage, etc.) and make notes on all relevant details and circumstances before leaving the scene.

**PREPARE A COMPLETE REPORT** detailing the incident immediately after leaving the scene upon returning to the work place and submit it to the immediate supervisor.

### 3.3.5 Emergency Medical Care

Accident situations requiring emergency medical care are likely to involve acute exposure to potentially toxic chemicals. Instructions for handling these exposures appear on the chemical label. Workers should:

1. Be aware of the symptoms of acute exposures for each chemical being used.
2. Have a predetermined strategy for dealing with exposure scenarios, including knowing (a) the label recommendations for dealing with acute exposures and (b) the nearest medical facility where emergency care is available.

### 3.3.6 Equipment and Equipment Maintenance

All equipment for the handling of pesticides should be inspected and cleaned by workers before each use to ensure that there are no problems that could lead to chemical leaks, spills or accidents during the day's work (State Code Ch. 3, Subch. 3, Art. 2).

### 3.3.7 Groundwater and Surface Water Protection

Similar to the discussion of leaching in fertilizer management, the main factors determining the rate at which pesticides enter groundwater and surface water systems are chemical mobility, solubility and persistence and the soil type. For example, potentially dangerous chemicals are likely to have a high solubility and an extremely long half-life, and they are not likely to be easily absorbed into the soil. Therefore, chemicals that decompose rapidly may be preferred. However, note that to choose a chemical that may need to be applied two or three times as often may not make sense from a transportation and application risk standpoint.

Because of these factors, regardless of the category of chemicals being used, pesticide advisors should always test the soil for compatibility with specific chemicals before recommending pesticides for a specific area.

Furthermore, because the effect of these uses is not always immediately apparent, public agencies should periodically test areas that could be particularly vulnerable to contamination or deterioration. The results of these tests should be kept on public record.

## **3.4 Application of Pesticides**

### 3.4.1 Supervision

1. In cases where supervision of pesticide applications is required by the State Code, supervision must be handled by a state-licensed or certified pesticide applicator. For all other pesticide applications, supervision may be handled by workers with equivalent training.
2. Public agencies that contract pesticide applications should periodically inspect contracted work crews to be certain that contractors are following proper management guidelines. Public agencies handling their own applications should likewise inspect their work crews on a regular basis to ensure that safety standards are being met.

### 3.4.2 Proper Techniques

1. Read the label carefully and follow application instructions exactly. Be absolutely certain that the right chemical is being used for the right job before applying.
2. To prevent potentially harmful runoff, only the absolute minimum amount of pesticides should be used to ensure vegetation safety.
3. Recommendations for best weather conditions to prevent pesticide spray drift are outlined in State Code Chapter 2, Subchapter 4, Article 2.

### 3.4.3 User Safety and Protection

1. Public agencies should have on hand equipment for application of pesticides should include eye protection, gloves, respiratory gear and impervious full-body, chemical resistant clothing when called for by the chemical label.
2. Even when wearing respiratory gear or masks, when dealing with spray applications of pesticides, workers should avoid directly inhaling in the spray mist.
3. Workers should avoid working alone, especially at night.
4. Workers should clean equipment, clothing and self thoroughly after each application.
5. State laws regarding re-entry into fields that have recently been treated with pesticides should be followed (State Code Chapter 3, Subchapter 3, Article 3).
6. Public agencies are responsible for knowing and informing workers about the specific pesticides being used including how they are properly handled, the dangers involved and the proper training and safety procedures.
7. Public agencies are responsible for keeping updated records and a complete list of the pesticides being used in their jurisdiction. This should include the chemicals, amount in storage, amount of applications, dates and location of applications and pests controlled with each application.
8. Public agencies should keep all relevant label and MSDS information for each chemical updated and readily available at all times to workers handling the materials.

### **3.5 Storage, Disposal and Transportation**

#### 3.5.1 Proper Storage

1. Storage areas should be away from living areas and in a covered area that is well-insulated from temperature extremes; they should have a cement floor and good ventilation. Also, storage areas should be clearly marked according to state standards and be securely locked at all times when not in use.
2. Public agencies should ensure that chemical labels on pesticides being stored or used are kept in good condition and attached to all containers holding pesticides (State Code Ch. 3, Subch. 2, Art. 4).
3. Workers should ensure that storage equipment and containers are inspected daily for leaks or defects before being taken on the job. Containers should also be inspected and before storing at the end of the day.

#### 3.5.2 Proper Disposal

1. Workers should make certain that chemical containers are triple-rinsed before disposal (State Code Ch. 3, Subch. 2)
2. It is recommended that cleaned containers be sent back to the manufacturer for recycling whenever possible. However, once triple-rinsed, most haulers will take them to most landfills.
3. Workers should use left over rinse water as spray.
4. Public agencies should ensure that surplus or out-of-date chemicals are given to a licensed hazardous waste hauler for disposal.

#### 3.5.3 Safe Transportation Methods

1. Workers should ensure that all pesticides containers are tightly sealed and secured from tipping or excess jarring (State Code Ch. 3, Subch. 2, Art. 4).
2. Transportation compartments on vehicles should be isolated from the compartment carrying people, food and clothing and should be securely locked (State Code Ch. 3, Subch. 2, Art. 4).
3. Workers should transport only the amount of pesticide needed for the day to the site.
4. Workers should be certain that the appropriate chemical labels and MSDS sheets, a spill cleanup kit, the location of emergency medical care and a first aid kit are always brought along when transporting pesticides.

5. Public agencies should encourage all vehicles used for pesticide transportation to include radio communications for contacting help in case of a spill or some other emergency.

#### **4.0 INTEGRATED PEST MANAGEMENT\***

##### **4.1 Background on Pesticide Use**

For most of the last 50 years, the trend in vegetation management has been toward a greater reliance on pesticides. The result has been not only a tremendous increase in the use of many dangerous chemicals, but also an enormous increase in the number of pests that are resistant to the pesticides being produced. In essence, as more pesticides have been produced, more resistant strains of pests have evolved. Worse, recent studies have shown that the end result of this global trend has been no net gain in vegetation survival rates.

With these realizations becoming well known, vegetation managers are now moving away from their reliance on pesticides and toward an integrated approach that combines limited pesticides use with more environmentally-friendly pest control techniques.

##### **4.2 Scope of Guidelines**

For public agencies in Orange County, IPM practices should be preferred to the sole use of pesticides as the primary means of vegetation management. These techniques are designed to prevent overuse and to reduce reliance on them. IPM should be considered by all public agencies or their contractors before intensive use of pesticides.

The goal of IPM is not to eliminate all pests, but to keep their populations at a manageable number. Pesticides are part of IPM techniques, but they are used in small quantities and only after all other alternatives have been reviewed.

##### **4.3 Alternatives to Pesticides**

Some of the alternatives to pesticides that may be considered as part of an IPM program include:

1. Introduction of natural predators such as ladybugs, lacewings, garter snakes and toads. Also, some bacteria, viruses and insect parasites may be preferable to pesticides.
2. Selected removal or rotation of vegetation habitat to eliminate the breeding places of specific pests.
3. Weeding, hoeing and trapping manually. Pruning and thinning of trees is also an effective means of preventing epidemic tree insects and diseases.

Also, at certain times of the year and under certain environmental conditions, certain pests can be expected. Therefore, timely planting or well-timed use of small quantities of pesticides may avoid the need for some chemical use.

## REFERENCES

- California Department of Food and Agriculture, Nitrate Working Group. **Nitrate and Agriculture in California**. 1989.
- California Department of Food and Agriculture, Pesticides and Pest Control Operations. **Barclays Official California Code of Regulations - 1992**.
- California Fertilizer Association. **Guidelines for Protection of Water Quality at Retail Fertilizer Facilities**. 1988.
- California Fertilizer Association, Soil Improvement Committee. **Western Fertilizer Handbook**. 1985.
- California Regional Water Quality Control Board, Santa Ana Region. **Stormwater Management Manual for Puget Sound**. 1990.
- California Regional Water Quality Control Board, Santa Ana Region. **Order No. 90-71, NPDES No. CA 8000180**. 1990.
- California Regional Water Quality Control Board, Santa Ana Region. **Order No. 96-31, NPDES No. CAS618030**. 1996.
- California Regional Water Quality Control Board, Santa Ana Region. **Order No. 90-38, NPDES No. CA 0108740**. 1990.
- California Regional Water Quality Control Board, Santa Ana Region. **Order No. 96-03, NPDES No. CAS0108740**. 1996.
- City of Mission Viejo. **Specifications for the Maintenance of Municipal Landscapes of Mission Viejo**. 1989.
- City of San Clemente, Parks Div. **Herbicides & Pesticides Safety Manual** 1991.
- City of Tustin. **Hazard Communication Employee Training**. 1992.
- County of Orange, Environmental Resources Division. **Drainage Area Management Plan, Final Draft**. 1991.
- County of Orange, Environmental Resources Division. **Drainage Area Management Plan**. 1993.
- County of Orange, Environmental Resources Division. **Management of Pesticides, Herbicides and Fertilizers: A Survey to Help Establish Guidelines**. 1992.

## REFERENCES (cont'd)

Environmental Impact Profiles. Environmental Impact Report: **Vegetation and Pest Management Program for Orange County Flood Control District**, 1974.

Fitzgerald, Wendy S. (California Department of Water Resources, Flood Project Analysis). **Levee Management Plans, Sutter Yard**, 1989-90.

Monsanto Agricultural Co. **A Natural Balance: Restoring Native Habitats** 1991.

United States Department of Agriculture. **Final Environmental Impact Statement: Vegetation Management in the Coastal Plain/Piedmont, Volumes 1-3**. 1989.

University of California, Division of Agricultural Sciences. **Safe Handling of Agricultural Pesticides**. 1978.

University of California, Division of Agriculture and Natural Resources. **The Safe and Effective Use of Pesticides**. 1990.



Graphic by: Margie Winter

## Description

Non-stormwater discharges are those flows that do not consist entirely of stormwater. For municipalities non-stormwater discharges present themselves in two situations. One is from fixed facilities owned and/or operated by the municipality. The other situation is non-stormwater discharges that are discovered during the normal operation of a field program. Some non-stormwater discharges do not include pollutants and may be discharged to the storm drain. These include uncontaminated groundwater and natural springs. There are also some non-stormwater discharges that typically do not contain pollutants and may be discharged to the storm drain with conditions. These include car washing, and surface cleaning. However, there are certain non-stormwater discharges that pose environmental concern. These discharges may originate from illegal dumping or from internal floor drains, appliances, industrial processes, sinks, and toilets that are connected to the nearby storm drainage system. These discharges (which may include: process waste waters, cooling waters, wash waters, and sanitary wastewater) can carry substances (such as paint, oil, fuel and other automotive fluids, chemicals and other pollutants) into storm drains. The ultimate goal is to effectively eliminate non-stormwater discharges to the stormwater drainage system through implementation of measures to detect, correct, and enforce against illicit connections and illegal discharges.

## Approach

The municipality must address non-stormwater discharges from its fixed facilities by assessing the types of non-stormwater discharges and implementing BMPs for the discharges determined to pose environmental concern. For field programs

## Objectives

- Contain
- Educate
- Reduce/Minimize

## Targeted Constituents

Sediment	<input checked="" type="checkbox"/>
Nutrients	<input checked="" type="checkbox"/>
Trash	<input checked="" type="checkbox"/>
Metals	<input checked="" type="checkbox"/>
Bacteria	<input checked="" type="checkbox"/>
Oil and Grease	<input checked="" type="checkbox"/>
Organics	<input checked="" type="checkbox"/>
Oxygen Demanding	<input checked="" type="checkbox"/>



the field staff must be trained to know what to look for regarding non-stormwater discharges and the procedures to follow in investigating the detected discharges.

## ***Suggested Protocols***

### **Fixed Facility**

#### *General*

- Post “No Dumping” signs with a phone number for reporting dumping and disposal. Signs should also indicate fines and penalties for illegal dumping.
- Stencil storm drains, where applicable, to prevent illegal disposal of pollutants. Storm drain inlets should have messages such as “Dump No Waste Drains to Stream” stenciled next to them to warn against ignorant or intentional dumping of pollutants into the storm drainage system.
- Landscaping and beautification efforts of hot spots might also discourage future dumping, as well as provide open space and increase property values.
- Lighting or barriers may also be needed to discourage future dumping.

#### *Illicit Connections*

- Locate discharges from the fixed facility drainage system to the municipal storm drain system through review of “as-built” piping schematics.
- Use techniques such as smoke testing, dye testing and television camera inspection (as noted below) to verify physical connections.
- Isolate problem areas and plug illicit discharge points.

#### *Visual Inspection and Inventory*

- Inventory and inspect each discharge point during dry weather.
- Keep in mind that drainage from a storm event can continue for several days following the end of a storm and groundwater may infiltrate the underground stormwater collection system. Also, non-stormwater discharges are often intermittent and may require periodic inspections.

#### *Review Infield Piping*

- Review the “as-built” piping schematic as a way to determine if there are any connections to the stormwater collection system.
- Inspect the path of floor drains in older buildings.

#### *Smoke Testing*

- Smoke testing of wastewater and stormwater collection systems is used to detect connections between the two systems.

- During dry weather the stormwater collection system is filled with smoke and then traced to sources. The appearance of smoke at the base of a toilet indicates that there may be a connection between the sanitary and the stormwater system.

### *Dye Testing*

- A dye test can be performed by simply releasing a dye into either your sanitary or process wastewater system and examining the discharge points from the stormwater collection system for discoloration.

### *TV Inspection of Storm Sewer*

- TV Cameras can be employed to visually identify illicit connections to the fixed facility storm drain system.

### *Illegal Dumping*

- Regularly inspect and clean up hot spots and other storm drainage areas where illegal dumping and disposal occurs.
- Clean up spills on paved surfaces with as little water as possible. Use a rag for small spills, a damp mop for general cleanup, and absorbent material for larger spills. If the spilled material is hazardous, then the used cleanup materials are also hazardous and must be sent to a certified laundry (rags) or disposed of as hazardous waste.
- Never hose down or bury dry material spills. Sweep up the material and dispose of properly.
- Use adsorbent materials on small spills rather than hosing down the spill. Remove the adsorbent materials promptly and dispose of properly.
- For larger spills, a private spill cleanup company or Hazmat team may be necessary.
- See fact sheet SC-11 Spill Prevention, Control, and Clean Up.

### **Field Program**

#### *General*

- Develop clear protocols and lines of communication for effectively prohibiting non-stormwater discharges, especially ones that involve more than one jurisdiction and those that are not classified as hazardous, which are often not responded to as effectively as they need to be.
- Stencil storm drains, where applicable, to prevent illegal disposal of pollutants. Storm drain inlets should have messages such as “Dump No Waste Drains to Stream” stenciled next to them to warn against ignorant or intentional dumping of pollutants into the storm drainage system.
- See SC-74 Stormwater Drainage System Maintenance for additional information.

## *Field Inspection*

- Regularly inspect and clean up hot spots and other storm drainage areas where illegal dumping and disposal occurs.
- During routine field program maintenance field staff should look for evidence of illegal discharges or illicit connection:
  - Is there evidence of spills such as paints, discoloring, etc.
  - Are there any odors associated with the drainage system
  - Record locations of apparent illegal discharges/illicit connections and notify appropriate investigating agency.
- If trained, conduct field investigation of non-stormwater discharges to determine whether they pose a threat to water quality.

## *Recommended Complaint Investigation Equipment*

- Field Screening Analysis
  - pH paper or meter
  - Commercial stormwater pollutant screening kit that can detect for reactive phosphorus, nitrate nitrogen, ammonium nitrogen, specific conductance, and turbidity
  - Sample jars
  - Sample collection pole
  - A tool to remove access hole covers
- Laboratory Analysis
  - Sample cooler
  - Ice
  - Sample jars and labels
  - Chain of custody forms.
- Documentation
  - Camera
  - Notebook
  - Pens
  - Notice of Violation forms

- Educational materials

## *Reporting*

- A database is useful for defining and tracking the magnitude and location of the problem.
- Report prohibited non-stormwater discharges observed during the course of normal daily activities so they can be investigated, contained and cleaned up or eliminated.
- Document that non-stormwater discharges have been eliminated by recording tests performed, methods used, dates of testing, and any onsite drainage points observed.
- Maintain documentation of illicit connection and illegal dumping incidents, including significant conditionally exempt discharges that are not properly managed.

## *Enforcement*

- Educate the responsible party if identified on the impacts of their actions, explain the stormwater requirements, and provide information regarding Best Management Practices (BMP), as appropriate. Initiate follow-up and/or enforcement procedures.
- If an illegal discharge is traced to a commercial, residential or industrial source, conduct the following activities or coordinate the following activities with the appropriate agency:
  - Contact the responsible party to discuss methods of eliminating the non-stormwater discharge, including disposal options, recycling, and possible discharge to the sanitary sewer (if within POTW limits).
  - Provide information regarding BMPs to the responsible party, where appropriate.
  - Begin enforcement procedures, if appropriate.
  - Continue inspection and follow-up activities until the illicit discharge activity has ceased.
- If an illegal discharge is traced to a commercial or industrial activity, coordinate information on the discharge with the jurisdiction's commercial and industrial facility inspection program.

## *Training*

- Train technical staff to identify and document illegal dumping incidents.
- Well-trained employees can reduce human errors that lead to accidental releases or spills. The employee should have the tools and knowledge to immediately begin cleaning up a spill if one should occur. Employees should be familiar with the Spill Prevention Control and Countermeasure Plan.
- Train employees to identify non-stormwater discharges and report them to the appropriate departments.
- Train staff who have the authority to conduct surveillance and inspections, and write citations for those caught illegally dumping.

- Train municipal staff responsible for surveillance and inspection in the following:
  - OSHA-required Health and Safety Training (29 CFR 1910.120) plus annual refresher training (as needed).
  - OSHA Confined Space Entry training (Cal-OSHA Confined Space, Title 8 and federal OSHA 29 CFR 1910.146).
  - Procedural training (field screening, sampling, smoke/dye testing, TV inspection).
- Educate the identified responsible party on the impacts of his or her actions.

***Spill Response and Prevention***

- See SC-11 Spill Prevention Control and Clean Up

***Other Considerations***

- The elimination of illegal dumping is dependent on the availability, convenience, and cost of alternative means of disposal. The cost of fees for dumping at a proper waste disposal facility are often more than the fine for an illegal dumping offense, thereby discouraging people from complying with the law. The absence of routine or affordable pickup service for trash and recyclables in some communities also encourages illegal dumping. A lack of understanding regarding applicable laws or the inadequacy of existing laws may also contribute to the problem.
- Municipal codes should include sections prohibiting the discharge of soil, debris, refuse, hazardous wastes, and other pollutants into the storm drain system.
- Many facilities do not have accurate, up-to-date schematic drawings.
- Can be difficult to locate illicit connections especially if there is groundwater infiltration.

**Requirements*****Costs***

- Eliminating illicit connections can be expensive especially if structural modifications are required such re-plumbing cross connections under an existing slab.
- Minor cost to train field crews regarding the identification of non-stormwater discharges. The primary cost is for a fully integrated program to identify and eliminate illicit connections and illegal dumping. However, by combining with other municipal programs (i.e. pretreatment program) cost may be lowered.
- Municipal cost for containment and disposal may be borne by the discharger.

***Maintenance***

Not applicable

## Supplemental Information

### *Further Detail of the BMP*

*What constitutes a “non-stormwater” discharge?*

- Non-stormwater discharges are discharges not made up entirely of stormwater and include water used directly in the manufacturing process (process wastewater), air conditioning condensate and coolant, non-contact cooling water, cooling equipment condensate, outdoor secondary containment water, vehicle and equipment wash water, landscape irrigation, sink and drinking fountain wastewater, sanitary wastes, or other wastewaters.

### *Permit Requirements*

- Current municipal NPDES permits require municipalities to effectively prohibit non-stormwater discharges unless authorized by a separate NPDES permit or allowed in accordance with the current NPDES permit conditions. Typically the current permits allow certain non-stormwater discharges in the storm drain system as long as the discharges are not significant sources of pollutants. In this context the following non-stormwater discharges are typically allowed:
  - Diverted stream flows;
  - Rising found waters;
  - Uncontaminated ground water infiltration (as defined at 40 CFR 35.2005(20));
  - Uncontaminated pumped ground water;
  - Foundation drains;
  - Springs;
  - Water from crawl space pumps;
  - Footing drains;
  - Air conditioning condensation;
  - Flows from riparian habitats and wetlands;
  - Water line and hydrant flushing ;
  - Landscape irrigation;
  - Planned and unplanned discharges from potable water sources;
  - Irrigation water;
  - Individual residential car washing; and
  - Lawn watering.

Municipal facilities subject to industrial general permit requirements must include a certification that the stormwater collection system has been tested or evaluated for the presence of non-stormwater discharges. The state's General Industrial Stormwater Permit requires that non-stormwater discharges be eliminated prior to implementation of the facility's SWPPP.

### *Illegal Dumping*

- Establish a system for tracking incidents. The system should be designed to identify the following:
  - Illegal dumping hot spots
  - Types and quantities (in some cases) of wastes
  - Patterns in time of occurrence (time of day/night, month, or year)
  - Mode of dumping (abandoned containers, "midnight dumping" from moving vehicles, direct dumping of materials, accidents/spills)
  - Responsible parties

### *Outreach*

One of the keys to success of reducing or eliminating illegal dumping is increasing the number of people on the street who are aware of the problem and who have the tools to at least identify the incident, if not correct it. There are a number of ways of accomplishing this:

- Train municipal staff from all departments (public works, utilities, street cleaning, parks and recreation, industrial waste inspection, hazardous waste inspection, sewer maintenance) to recognize and report the incidents.
- Deputize municipal staff who may come into contact with illegal dumping with the authority to write illegal dumping tickets for offenders caught in the act (see below).
- Educate the public. As many as 3 out of 4 people do not understand that in most communities the storm drain does not go to the wastewater treatment plant. Unfortunately, with the heavy emphasis in recent years on public education about solid waste management, including recycling and household hazardous waste, the sewer system (both storm and sanitary) has been the likely recipient of cross-media transfers of waste.
- Provide the public with a mechanism for reporting incidents such as a hot line and/or door hanger (see below).
- Help areas where incidents occur more frequently set up environmental watch programs (like crime watch programs).
- Train volunteers to notice and report the presence and suspected source of an observed pollutant to the appropriate public agency.

*What constitutes a “non-stormwater” discharge?*

- Non-stormwater discharges are discharges not made up entirely of stormwater and include water used directly in the manufacturing process (process wastewater), air conditioning condensate and coolant, non-contact cooling water, cooling equipment condensate, outdoor secondary containment water, vehicle and equipment wash water, landscape irrigation, sink and drinking fountain wastewater, sanitary wastes, or other wastewaters.

*Permit Requirements*

- Current municipal NPDES permits require municipalities to effectively prohibit non-stormwater discharges unless authorized by a separate NPDES permit or allowed in accordance with the current NPDES permit conditions. Typically the current permits allow certain non-stormwater discharges in the storm drain system as long as the discharges are not significant sources of pollutants. In this context the following non-stormwater discharges are typically allowed:
  - Diverted stream flows;
  - Rising found waters;
  - Uncontaminated ground water infiltration (as defined at 40 CFR 35.2005(20));
  - Uncontaminated pumped ground water;
  - Foundation drains;
  - Springs;
  - Water from crawl space pumps;
  - Footing drains;
  - Air conditioning condensation;
  - Flows from riparian habitats and wetlands;
  - Water line and hydrant flushing ;
  - Landscape irrigation;
  - Planned and unplanned discharges from potable water sources;
  - Irrigation water;
  - Individual residential car washing; and
  - Lawn watering.

Municipal facilities subject to industrial general permit requirements must include a certification that the stormwater collection system has been tested or evaluated for the presence

of non-stormwater discharges. The state's General Industrial Stormwater Permit requires that non-stormwater discharges be eliminated prior to implementation of the facility's SWPPP.

#### *Storm Drain Stenciling*

- Stencil storm drain inlets with a message to prohibit illegal dumpings, especially in areas with waste handling facilities.
- Encourage public reporting of improper waste disposal by a HOTLINE number stenciled onto the storm drain inlet.
- See Supplemental Information section of this fact sheet for further detail on stenciling program approach.

#### *Oil Recycling*

- Contract collection and hauling of used oil to a private licensed used oil hauler/recycler.
- Comply with all applicable state and federal regulations regarding storage, handling, and transport of petroleum products.
- Create procedures for collection such as; collection locations and schedule, acceptable containers, and maximum amounts accepted.
- The California Integrated Waste Management Board has a Recycling Hotline, (800) 553-2962, that provides information and recycling locations for used oil.

#### ***Household Hazardous Waste***

- Provide household hazardous waste (HHW) collection facilities. Several types of collection approaches are available including permanent, periodic, or mobile centers, curbside collection, or a combination of these systems.

#### ***Training***

- Train municipal employees and contractors in proper and consistent methods for waste disposal.
- Train municipal employees to recognize and report illegal dumping.
- Train employees and subcontractors in proper hazardous waste management.

#### ***Spill Response and Prevention***

- Refer to SC-11, Spill Prevention, Control & Cleanup
- Have spill cleanup materials readily available and in a known location.
- Cleanup spills immediately and use dry methods if possible.
- Properly dispose of spill cleanup material.

## ***Other Considerations***

- Federal Regulations (RCRA, SARA, CERCLA) and state regulations exist regarding the disposal of hazardous waste.
- Municipalities are required to have a used oil recycling element and a HHW element within their integrated waste management plan.
- Significant liability issues are involved with the collection, handling, and disposal of HHW.

## ***Examples***

The City of Palo Alto has developed a public participation program for reporting dumping violations. When a concerned citizen or public employee encounters evidence of illegal dumping, a door hanger (similar in format to hotel “Do Not Disturb” signs) is placed on the front doors in the neighborhood. The door hanger notes that a violation has occurred in the neighborhood, informs the reader why illegal dumping is a problem, and notes that illegal dumping carries a significant financial penalty. Information is also provided on what citizens can do as well as contact numbers for more information or to report a violation.

The Port of Long Beach has a state of the art database incorporating storm drain infrastructure, potential pollutant sources, facility management practices, and a pollutant tracking system.

The State Department of Fish and Game has a hotline for reporting violations called CalTIP (1-800-952-5400). The phone number may be used to report any violation of a Fish and Game code (illegal dumping, poaching, etc.).

The California Department of Toxic Substances Control’s Waste Alert Hotline, 1-800-69TOXIC, can be used to report hazardous waste violations.

## **References and Resources**

<http://www.stormwatercenter.net/>

California’s Nonpoint Source Program Plan <http://www.co.clark.wa.us/pubworks/bmpman.pdf>

King County Stormwater Pollution Control Manual - <http://dnr.metrokc.gov/wlr/dss/spcm.htm>

Orange County Stormwater Program,  
[http://www.ocwatersheds.com/stormwater/swp\\_introduction.asp](http://www.ocwatersheds.com/stormwater/swp_introduction.asp)

San Diego Stormwater Co-permittees Jurisdictional Urban Runoff Management Program  
(<http://www.projectcleanwater.org>)

Santa Clara Valley Urban Runoff Pollution Prevention Program  
[http://www.scvurppp-w2k.com/pdf%20documents/PS\\_ICID.PDF](http://www.scvurppp-w2k.com/pdf%20documents/PS_ICID.PDF)

# Spill Prevention, Control & Cleanup SC-11



## Objectives

- Cover
- Contain
- Educate
- Reduce/Minimize
- Product Substitution

## Description

Spills and leaks, if not properly controlled, can adversely impact the storm drain system and receiving waters. Due to the type of work or the materials involved, many activities that occur either at a municipal facility or as a part of municipal field programs have the potential for accidental spills and leaks. Proper spill response planning and preparation can enable municipal employees to effectively respond to problems when they occur and minimize the discharge of pollutants to the environment.

## Approach

- An effective spill response and control plan should include:
  - Spill/leak prevention measures;
  - Spill response procedures;
  - Spill cleanup procedures;
  - Reporting; and
  - Training
- A well thought out and implemented plan can prevent pollutants from entering the storm drainage system and can be used as a tool for training personnel to prevent and control future spills as well.

## Pollution Prevention

- Develop and implement a Spill Prevention Control and Response Plan. The plan should include:

## Targeted Constituents

Sediment	
Nutrients	☑
Trash	
Metals	☑
Bacteria	
Oil and Grease	☑
Organics	☑
Oxygen Demanding	☑



# **SC-11 Spill Prevention, Control & Cleanup**

---

- A description of the facility, the address, activities and materials involved
- Identification of key spill response personnel
- Identification of the potential spill areas or operations prone to spills/leaks
- Identification of which areas should be or are bermed to contain spills/leaks
- Facility map identifying the key locations of areas, activities, materials, structural BMPs, etc.
- Material handling procedures
- Spill response procedures including:
  - Assessment of the site and potential impacts
  - Containment of the material
  - Notification of the proper personnel and evacuation procedures
  - Clean up of the site
  - Disposal of the waste material and
  - Proper record keeping
- Product substitution – use less toxic materials (i.e. use water based paints instead of oil based paints)
- Recycle, reclaim, or reuse materials whenever possible. This will reduce the amount of materials that are brought into the facility or into the field.

## ***Suggested Protocols***

### *Spill/Leak Prevention Measures*

- If possible, move material handling indoors, under cover, or away from storm drains or sensitive water bodies.
- Properly label all containers so that the contents are easily identifiable.
- Berm storage areas so that if a spill or leak occurs, the material is contained.
- Cover outside storage areas either with a permanent structure or with a seasonal one such as a tarp so that rain can not come into contact with the materials.
- Check containers (and any containment sumps) often for leaks and spills. Replace containers that are leaking, corroded, or otherwise deteriorating with containers in good condition. Collect all spilled liquids and properly dispose of them.

# Spill Prevention, Control & Cleanup SC-11

---

- Store, contain and transfer liquid materials in such a manner that if the container is ruptured or the contents spilled, they will not discharge, flow or be washed into the storm drainage system, surface waters, or groundwater.
- Place drip pans or absorbent materials beneath all mounted taps and at all potential drip and spill locations during the filling and unloading of containers. Any collected liquids or soiled absorbent materials should be reused/recycled or properly disposed of.
- For field programs, only transport the minimum amount of material needed for the daily activities and transfer materials between containers at a municipal yard where leaks and spill are easier to control.
- If paved, sweep and clean storage areas monthly, do not use water to hose down the area unless all of the water will be collected and disposed of properly.
- Install a spill control device (such as a tee section) in any catch basins that collect runoff from any storage areas if the materials stored are oil, gas, or other materials that separate from and float on water. This will allow for easier cleanup if a spill occurs.
- If necessary, protect catch basins while conducting field activities so that if a spill occurs, the material will be contained.

## ***Training***

- Educate employees about spill prevention, spill response and cleanup on a routine basis.
- Well-trained employees can reduce human errors that lead to accidental releases or spills:
  - The employees should have the tools and knowledge to immediately begin cleaning up a spill if one should occur.
  - Employees should be familiar with the Spill Prevention Control and Countermeasure Plan if one is available.
- Training of staff from all municipal departments should focus on recognizing and reporting potential or current spills/leaks and who they should contact.
- Employees responsible for aboveground storage tanks and liquid transfers for large bulk containers should be thoroughly familiar with the Spill Prevention Control and Countermeasure Plan and the plan should be readily available.

## ***Spill Response and Prevention***

- Identify key spill response personnel and train employees on who they are.
- Store and maintain appropriate spill cleanup materials in a clearly marked location near storage areas; and train employees to ensure familiarity with the site's spill control plan and/or proper spill cleanup procedures.
- Locate spill cleanup materials, such as absorbents, where they will be readily accessible (e.g. near storage and maintenance areas, on field trucks).

# **SC-11 Spill Prevention, Control & Cleanup**

---

- Follow the Spill Prevention Control and Countermeasure Plan if one is available.
- If a spill occurs, notify the key spill response personnel immediately. If the material is unknown or hazardous, the local fire department may also need to be contacted.
- If safe to do so, attempt to contain the material and block the nearby storm drains so that the area impacted is minimized. If the material is unknown or hazardous wait for properly trained personnel to contain the materials.
- Perform an assessment of the area where the spill occurred and the downstream area that it could impact. Relay this information to the key spill response and clean up personnel.

## *Spill Cleanup Procedures*

- Small non-hazardous spills
  - Use a rag, damp cloth or absorbent materials for general clean up of liquids
  - Use brooms or shovels for the general clean up of dry materials
  - If water is used, it must be collected and properly disposed of. The wash water can not be allowed to enter the storm drain.
  - Dispose of any waste materials properly

Clean or dispose of any equipment used to clean up the spill properly
- Large non-hazardous spills
  - Use absorbent materials for general clean up of liquids
  - Use brooms, shovels or street sweepers for the general clean up of dry materials
  - If water is used, it must be collected and properly disposed of. The wash water can not be allowed to enter the storm drain.
  - Dispose of any waste materials properly
  - Clean or dispose of any equipment used to clean up the spill properly
- For hazardous or very large spills, a private cleanup company or Hazmat team may need to be contacted to assess the situation and conduct the cleanup and disposal of the materials.
- Chemical cleanups of material can be achieved with the use of absorbents, gels, and foams. Remove the adsorbent materials promptly and dispose of according to regulations.
- If the spilled material is hazardous, then the used cleanup materials are also hazardous and must be sent to a certified laundry (rags) or disposed of as hazardous waste.

## *Reporting*

- Report any spills immediately to the identified key municipal spill response personnel.

# Spill Prevention, Control & Cleanup SC-11

---

- Report spills in accordance with applicable reporting laws. Spills that pose an immediate threat to human health or the environment must be reported immediately to the Office of Emergency Service (OES)
- Spills that pose an immediate threat to human health or the environment may also need to be reported within 24 hours to the Regional Water Quality Control Board.
- Federal regulations require that any oil spill into a water body or onto an adjoining shoreline be reported to the National Response Center (NRC) at 800-424-8802 (24 hour)
- After the spill has been contained and cleaned up, a detailed report about the incident should be generated and kept on file (see the section on Reporting below). The incident may also be used in briefing staff about proper procedures

## ***Other Considerations***

- State regulations exist for facilities with a storage capacity of 10,000 gallons or more of petroleum to prepare a Spill Prevention Control and Countermeasure Plan (SPCC) Plan (Health & Safety Code Chapter 6.67).
- State regulations also exist for storage of hazardous materials (Health & Safety Code Chapter 6.95), including the preparation of area and business plans for emergency response to the releases or threatened releases.
- Consider requiring smaller secondary containment areas (less than 200 sq. ft.) to be connected to the sanitary sewer, if permitted to do so, prohibiting any *hard connections* to the storm drain.

## **Requirements**

### ***Costs***

- Will vary depending on the size of the facility and the necessary controls.
- Prevention of leaks and spills is inexpensive. Treatment and/or disposal of wastes, contaminated soil and water is very expensive

### ***Maintenance***

- This BMP has no major administrative or staffing requirements. However, extra time is needed to properly handle and dispose of spills, which results in increased labor costs

## **Supplemental Information**

### ***Further Detail of the BMP***

#### ***Reporting***

Record keeping and internal reporting represent good operating practices because they can increase the efficiency of the response and containment of a spill. A good record keeping system helps the municipality minimize incident recurrence, correctly respond with appropriate containment and cleanup activities, and comply with legal requirements.

A record keeping and reporting system should be set up for documenting spills, leaks, and other discharges, including discharges of hazardous substances in reportable quantities. Incident records describe the quality and quantity of non-stormwater discharges to the storm drain.

# **SC-11 Spill Prevention, Control & Cleanup**

---

These records should contain the following information:

- Date and time of the incident
- Weather conditions
- Duration of the spill/leak/discharge
- Cause of the spill/leak/discharge
- Response procedures implemented
- Persons notified
- Environmental problems associated with the spill/leak/discharge

Separate record keeping systems should be established to document housekeeping and preventive maintenance inspections, and training activities. All housekeeping and preventive maintenance inspections should be documented. Inspection documentation should contain the following information:

- The date and time the inspection was performed
- Name of the inspector
- Items inspected
- Problems noted
- Corrective action required
- Date corrective action was taken

Other means to document and record inspection results are field notes, timed and dated photographs, videotapes, and drawings and maps.

## ***Examples***

The City of Palo Alto includes spill prevention and control as a major element of its highly effective program for municipal vehicle maintenance shops.

## **References and Resources**

King County Stormwater Pollution Control Manual - <http://dnr.metrokc.gov/wlr/dss/spcm.htm>

Orange County Stormwater Program

[http://www.ocwatersheds.com/stormwater/swp\\_introduction.asp](http://www.ocwatersheds.com/stormwater/swp_introduction.asp)

San Diego Stormwater Co-permittees Jurisdictional Urban Runoff Management Program (URMP)

<http://www.projectcleanwater.org/pdf/Model%20Program%20Municipal%20Facilities.pdf>



## Objectives

- Cover
- Contain
- Educate
- Reduce/Minimize
- Product Substitution

## Description

Improper storage and handling of solid wastes can allow toxic compounds, oils and greases, heavy metals, nutrients, suspended solids, and other pollutants to enter stormwater runoff. The discharge of pollutants to stormwater from waste handling and disposal can be prevented and reduced by tracking waste generation, storage, and disposal; reducing waste generation and disposal through source reduction, re-use, and recycling; and preventing runoff and runoff.

## Approach

### *Pollution Prevention*

- Reduction in the amount of waste generated can be accomplished using the following source controls such as:
  - Production planning and sequencing
  - Process or equipment modification
  - Raw material substitution or elimination
  - Loss prevention and housekeeping
  - Waste segregation and separation
  - Close loop recycling
- Establish a material tracking system to increase awareness about material usage. This may reduce spills and minimize contamination, thus reducing the amount of waste produced.
- Recycle materials whenever possible.

## Targeted Constituents

Sediment	<input checked="" type="checkbox"/>
Nutrients	<input checked="" type="checkbox"/>
Trash	<input checked="" type="checkbox"/>
Metals	<input checked="" type="checkbox"/>
Bacteria	<input checked="" type="checkbox"/>
Oil and Grease	<input checked="" type="checkbox"/>
Organics	<input checked="" type="checkbox"/>
Oxygen Demanding	<input checked="" type="checkbox"/>



***Suggested Protocols****General*

- Cover storage containers with leak proof lids or some other means. If waste is not in containers, cover all waste piles (plastic tarps are acceptable coverage) and prevent stormwater runoff and runoff with a berm. The waste containers or piles must be covered except when in use.
- Use drip pans or absorbent materials whenever grease containers are emptied by vacuum trucks or other means. Grease cannot be left on the ground. Collected grease must be properly disposed of as garbage.
- Check storage containers weekly for leaks and to ensure that lids are on tightly. Replace any that are leaking, corroded, or otherwise deteriorating.
- Sweep and clean the storage area regularly. If it is paved, do not hose down the area to a storm drain.
- Dispose of rinse and wash water from cleaning waste containers into a sanitary sewer if allowed by the local sewer authority. Do not discharge wash water to the street or storm drain.
- Transfer waste from damaged containers into safe containers.
- Take special care when loading or unloading wastes to minimize losses. Loading systems can be used to minimize spills and fugitive emission losses such as dust or mist. Vacuum transfer systems can minimize waste loss.

*Controlling Litter*

- Post “No Littering” signs and enforce anti-litter laws.
- Provide a sufficient number of litter receptacles for the facility.
- Clean out and cover litter receptacles frequently to prevent spillage.

*Waste Collection*

- Keep waste collection areas clean.
- Inspect solid waste containers for structural damage or leaks regularly. Repair or replace damaged containers as necessary.
- Secure solid waste containers; containers must be closed tightly when not in use.
- Place waste containers under cover if possible.
- Do not fill waste containers with washout water or any other liquid.
- Ensure that only appropriate solid wastes are added to the solid waste container. Certain wastes such as hazardous wastes, appliances, fluorescent lamps, pesticides, etc. may not be

disposed of in solid waste containers (see chemical/ hazardous waste collection section below).

- Do not mix wastes; this can cause chemical reactions, make recycling impossible, and complicate disposal.

### *Good Housekeeping*

- Use all of the product before disposing of the container.
- Keep the waste management area clean at all times by sweeping and cleaning up spills immediately.
- Use dry methods when possible (e.g. sweeping, use of absorbents) when cleaning around restaurant/food handling dumpster areas. If water must be used after sweeping/using absorbents, collect water and discharge through grease interceptor to the sewer.
- Stencil storm drains on the facility's property with prohibitive message regarding waste disposal.

### *Chemical/Hazardous Wastes*

- Select designated hazardous waste collection areas on-site.
- Store hazardous materials and wastes in covered containers protected from vandalism, and in compliance with fire and hazardous waste codes.
- Place hazardous waste containers in secondary containment.
- Make sure that hazardous waste is collected, removed, and disposed of only at authorized disposal areas.

### *Runon/Runoff Prevention*

- Prevent stormwater runon from entering the waste management area by enclosing the area or building a berm around the area.
- Prevent the waste materials from directly contacting rain.
- Cover waste piles with temporary covering material such as reinforced tarpaulin, polyethylene, polyurethane, polypropylene or hypalon.
- Cover the area with a permanent roof if feasible.
- Cover dumpsters to prevent rain from washing waste out of holes or cracks in the bottom of the dumpster.
- Move the activity indoor after ensuring all safety concerns such as fire hazard and ventilation are addressed.

### *Inspection*

- Inspect and replace faulty pumps or hoses regularly to minimize the potential of releases and spills.
- Check waste management areas for leaking containers or spills.
- Repair leaking equipment including valves, lines, seals, or pumps promptly.

***Training***

- Train staff pollution prevention measures and proper disposal methods.
- Train employees and contractors proper spill containment and cleanup. The employee should have the tools and knowledge to immediately begin cleaning up a spill if one should occur.
- Train employees and subcontractors in proper hazardous waste management.

***Spill Response and Prevention***

- Refer to SC-11, Spill Prevention, Control & Cleanup.
- Keep your Spill Prevention Control and countermeasure (SPCC) plan up-to-date, and implement accordingly.
- Have spill cleanup materials readily available and in a known location.
- Cleanup spills immediately and use dry methods if possible.
- Properly dispose of spill cleanup material.
- Vehicles transporting waste should have spill prevention equipment that can prevent spills during transport. The spill prevention equipment includes:
  - Vehicles equipped with baffles for liquid waste
  - Trucks with sealed gates and spill guards for solid waste

***Other Considerations***

- Hazardous waste cannot be re-used or recycled; it must be disposed of by a licensed hazardous waste hauler.

**Requirements*****Costs***

- Capital and operation and maintenance costs will vary substantially depending on the size of the facility and the types of waste handled. Costs should be low if there is an inventory program in place.

***Maintenance***

- None except for maintaining equipment for material tracking program.

## Supplemental Information

### *Further Detail of the BMP*

#### *Land Treatment System*

- Minimize the runoff of polluted stormwater from land application of municipal waste on-site by:
  - Choosing a site where slopes are under 6%, the soil is permeable, there is a low water table, it is located away from wetlands or marshes, there is a closed drainage system.
  - Avoiding application of waste to the site when it is raining or when the ground is saturated with water.
  - Growing vegetation on land disposal areas to stabilize soils and reduce the volume of surface water runoff from the site.
  - Maintaining adequate barriers between the land application site and the receiving waters. Planted strips are particularly good.
  - Using erosion control techniques such as mulching and matting, filter fences, straw bales, diversion terracing, and sediment basins.
  - Performing routine maintenance to ensure the erosion control or site stabilization measures are working.

## References and Resources

King County Stormwater Pollution Control Manual - <http://dnr.metrokc.gov/wlr/dss/spcm.htm>

Orange County Stormwater Program

[http://www.ocwatersheds.com/StormWater/swp\\_introduction.asp](http://www.ocwatersheds.com/StormWater/swp_introduction.asp)

Pollution from Surface Cleaning Folder. 1996. Bay Area Stormwater Management Agencies Associations (BASMAA). On-line: <http://www.basmaa.org>



## Description

Stormwater runoff from building and grounds maintenance activities can be contaminated with toxic hydrocarbons in solvents, fertilizers and pesticides, suspended solids, heavy metals, and abnormal pH. Utilizing the following protocols will prevent or reduce the discharge of pollutants to stormwater from building and grounds maintenance activities by washing and cleaning up with as little water as possible, following good landscape management practices, preventing and cleaning up spills immediately, keeping debris from entering the storm drains, and maintaining the stormwater collection system.

## Approach

### *Pollution Prevention*

- Switch to non-toxic chemicals for maintenance when possible.
- Choose cleaning agents that can be recycled.
- Encourage proper lawn management and landscaping, including use of native vegetation.
- Encourage use of Integrated Pest Management techniques for pest control.
- Encourage proper onsite recycling of yard trimmings.
- Recycle residual paints, solvents, lumber, and other material as much as possible.

## Objectives

- Cover
- Contain
- Educate
- Reduce/Minimize
- Product Substitution

## Targeted Constituents

Sediment	<input checked="" type="checkbox"/>
Nutrients	<input checked="" type="checkbox"/>
Trash	<input checked="" type="checkbox"/>
Metals	<input checked="" type="checkbox"/>
Bacteria	<input checked="" type="checkbox"/>
Oil and Grease	<input checked="" type="checkbox"/>
Organics	<input checked="" type="checkbox"/>
Oxygen Demanding	<input checked="" type="checkbox"/>



# SC-41 Building & Grounds Maintenance

---

## *Suggested Protocols*

### *Pressure Washing of Buildings, Rooftops, and Other Large Objects*

- In situations where soaps or detergents are used and the surrounding area is paved, pressure washers must use a waste water collection device that enables collection of wash water and associated solids. A sump pump, wet vacuum or similarly effective device must be used to collect the runoff and loose materials. The collected runoff and solids must be disposed of properly.
- If soaps or detergents are not used, and the surrounding area is paved, wash water runoff does not have to be collected but must be screened. Pressure washers must use filter fabric or some other type of screen on the ground and/or in the catch basin to trap the particles in wash water runoff.
- If you are pressure washing on a grassed area (with or without soap), runoff must be dispersed as sheet flow as much as possible, rather than as a concentrated stream. The wash runoff must remain on the grass and not drain to pavement. Ensure that this practice does not kill grass.

### *Landscaping Activities*

- Do not apply any chemicals (insecticide, herbicide, or fertilizer) directly to surface waters, unless the application is approved and permitted by the state.
- Dispose of grass clippings, leaves, sticks, or other collected vegetation as garbage, or by composting. Do not dispose of collected vegetation into waterways or storm drainage systems.
- Use mulch or other erosion control measures on exposed soils.
- Check irrigation schedules so pesticides will not be washed away and to minimize non-stormwater discharge.

### *Building Repair, Remodeling, and Construction*

- Do not dump any toxic substance or liquid waste on the pavement, the ground, or toward a storm drain.
- Use ground or drop cloths underneath outdoor painting, scraping, and sandblasting work, and properly dispose of collected material daily.
- Use a ground cloth or oversized tub for activities such as paint mixing and tool cleaning.
- Clean paint brushes and tools covered with water-based paints in sinks connected to sanitary sewers or in portable containers that can be dumped into a sanitary sewer drain. Brushes and tools covered with non-water-based paints, finishes, or other materials must be cleaned in a manner that enables collection of used solvents (e.g., paint thinner, turpentine, etc.) for recycling or proper disposal.

- Use a storm drain cover, filter fabric, or similarly effective runoff control mechanism if dust, grit, wash water, or other pollutants may escape the work area and enter a catch basin. The containment device(s) must be in place at the beginning of the work day, and accumulated dirty runoff and solids must be collected and disposed of before removing the containment device(s) at the end of the work day.
- If you need to de-water an excavation site, you may need to filter the water before discharging to a catch basin or off-site. In which case you should direct the water through hay bales and filter fabric or use other sediment filters or traps
- Store toxic material under cover with secondary containment during precipitation events and when not in use. A cover would include tarps or other temporary cover material.

### *Mowing, Trimming, and Planting*

- Dispose of leaves, sticks, or other collected vegetation as garbage, by composting or at a permitted landfill. Do not dispose of collected vegetation into waterways or storm drainage systems.
- Use mulch or other erosion control measures when soils are exposed.
- Place temporarily stockpiled material away from watercourses and drain inlets, and berm or cover stockpiles to prevent material releases to the storm drain system.
- Consider an alternative approach when bailing out muddy water; do not put it in the storm drain, pour over landscaped areas.
- Use hand or mechanical weeding where practical.

### *Fertilizer and Pesticide Management*

- Follow all federal, state, and local laws and regulations governing the use, storage, and disposal of fertilizers and pesticides and training of applicators and pest control advisors.
- Follow manufacturers' recommendations and label directions. Pesticides must never be applied if precipitation is occurring or predicted. Do not apply insecticides within 100 feet of surface waters such as lakes, ponds, wetlands, and streams.
- Use less toxic pesticides that will do the job, whenever possible. Avoid use of copper-based pesticides if possible.
- Do not use pesticides if rain is expected.
- Do not mix or prepare pesticides for application near storm drains.
- Use the minimum amount needed for the job.
- Calibrate fertilizer distributors to avoid excessive application.
- Employ techniques to minimize off-target application (e.g. spray drift) of pesticides, including consideration of alternative application techniques.

# SC-41 Building & Grounds Maintenance

---

- Apply pesticides only when wind speeds are low.
- Work fertilizers into the soil rather than dumping or broadcasting them onto the surface.
- Irrigate slowly to prevent runoff and then only as much as is needed.
- Clean pavement and sidewalk if fertilizer is spilled on these surfaces before applying irrigation water.
- Dispose of empty pesticide containers according to the instructions on the container label.
- Use up the pesticides. Rinse containers, and use rinse water as product. Dispose of unused pesticide as hazardous waste.
- Implement storage requirements for pesticide products with guidance from the local fire department and County Agricultural Commissioner. Provide secondary containment for pesticides.

## *Inspection*

- Inspect irrigation system periodically to ensure that the right amount of water is being applied and that excessive runoff is not occurring. Minimize excess watering, and repair leaks in the irrigation system as soon as they are observed.

## *Training*

- Educate and train employees on use of pesticides and in pesticide application techniques to prevent pollution.
- Train employees and contractors in proper techniques for spill containment and cleanup.
- Be sure the frequency of training takes into account the complexity of the operations and the nature of the staff.

## *Spill Response and Prevention*

- Refer to SC-11, Spill Prevention, Control & Cleanup
- Keep your Spill Prevention Control and countermeasure (SPCC) plan up-to-date, and implement accordingly.
- Have spill cleanup materials readily available and in a known location.
- Cleanup spills immediately and use dry methods if possible.
- Properly dispose of spill cleanup material.

## *Other Considerations*

- Alternative pest/weed controls may not be available, suitable, or effective in many cases.

## Requirements

### *Costs*

- Overall costs should be low in comparison to other BMPs.

### *Maintenance*

- Sweep paved areas regularly to collect loose particles, and wipe up spills with rags and other absorbent material immediately, do not hose down the area to a storm drain.

## Supplemental Information

### *Further Detail of the BMP*

#### *Fire Sprinkler Line Flushing*

Building fire sprinkler line flushing may be a source of non-stormwater runoff pollution. The water entering the system is usually potable water though in some areas it may be non-potable reclaimed wastewater. There are subsequent factors that may drastically reduce the quality of the water in such systems. Black iron pipe is usually used since it is cheaper than potable piping but it is subject to rusting and results in lower quality water. Initially the black iron pipe has an oil coating to protect it from rusting between manufacture and installation; this will contaminate the water from the first flush but not from subsequent flushes. Nitrates, poly-phosphates and other corrosion inhibitors, as well as fire suppressants and antifreeze may be added to the sprinkler water system. Water generally remains in the sprinkler system a long time, typically a year, between flushes and may accumulate iron, manganese, lead, copper, nickel and zinc. The water generally becomes anoxic and contains living and dead bacteria and breakdown products from chlorination. This may result in a significant BOD problem and the water often smells. Consequently dispose fire sprinkler line flush water into the sanitary sewer. Do not allow discharge to storm drain or infiltration due to potential high levels of pollutants in fire sprinkler line water.

## References and Resources

California's Nonpoint Source Program Plan <http://www.swrcb.ca.gov/nps/index.html>

King County - <ftp://dnr.metrokc.gov/wlr/dss/spcm/Chapter%203.PDF>

Orange County Stormwater Program

[http://www.ocwatersheds.com/StormWater/swp\\_introduction.asp](http://www.ocwatersheds.com/StormWater/swp_introduction.asp)

Mobile Cleaners Pilot Program: Final Report. 1997. Bay Area Stormwater Management Agencies Association (BASSMA) <http://www.basmaa.org/>

Pollution from Surface Cleaning Folder. 1996. Bay Area Stormwater Management Agencies Association (BASMAA) <http://www.basmaa.org/>

San Diego Stormwater Co-permittees Jurisdictional Urban Runoff Management Program (URMP) -

<http://www.projectcleanwater.org/pdf/Model%20Program%20Municipal%20Facilities.pdf>

# Parking/Storage Area Maintenance SC-43



## Description

Parking lots and storage areas can contribute a number of substances, such as trash, suspended solids, hydrocarbons, oil and grease, and heavy metals that can enter receiving waters through stormwater runoff or non-stormwater discharges. The following protocols are intended to prevent or reduce the discharge of pollutants from parking/storage areas and include using good housekeeping practices, following appropriate cleaning BMPs, and training employees.

## Approach

### *Pollution Prevention*

- Encourage alternative designs and maintenance strategies for impervious parking lots. (See New Development and Redevelopment BMP Handbook).
- Keep accurate maintenance logs to evaluate BMP implementation.

### *Suggested Protocols*

#### *General*

- Keep the parking and storage areas clean and orderly. Remove debris in a timely fashion.
- Allow sheet runoff to flow into biofilters (vegetated strip and swale) and/or infiltration devices.
- Utilize sand filters or oleophilic collectors for oily waste in low concentrations.

## Objectives

- Cover
- Contain
- Educate
- Reduce/Minimize
- Product Substitution

## Targeted Constituents

Sediment	<input checked="" type="checkbox"/>
Nutrients	<input checked="" type="checkbox"/>
Trash	<input checked="" type="checkbox"/>
Metals	<input checked="" type="checkbox"/>
Bacteria	<input checked="" type="checkbox"/>
Oil and Grease	<input checked="" type="checkbox"/>
Organics	<input checked="" type="checkbox"/>
Oxygen Demanding	<input checked="" type="checkbox"/>



# **SC-43 Parking/Storage Area Maintenance**

---

- Arrange rooftop drains to prevent drainage directly onto paved surfaces.
- Design lot to include semi-permeable hardscape.

## *Controlling Litter*

- Post “No Littering” signs and enforce anti-litter laws.
- Provide an adequate number of litter receptacles.
- Clean out and cover litter receptacles frequently to prevent spillage.
- Provide trash receptacles in parking lots to discourage litter.
- Routinely sweep, shovel and dispose of litter in the trash.

## *Surface cleaning*

- Use dry cleaning methods (e.g. sweeping or vacuuming) to prevent the discharge of pollutants into the stormwater conveyance system.
- Establish frequency of public parking lot sweeping based on usage and field observations of waste accumulation.
- Sweep all parking lots at least once before the onset of the wet season.
- If water is used follow the procedures below:
  - Block the storm drain or contain runoff.
  - Wash water should be collected and pumped to the sanitary sewer or discharged to a pervious surface, do not allow wash water to enter storm drains.
  - Dispose of parking lot sweeping debris and dirt at a landfill.
- When cleaning heavy oily deposits:
  - Use absorbent materials on oily spots prior to sweeping or washing.
  - Dispose of used absorbents appropriately.

## *Surface Repair*

- Pre-heat, transfer or load hot bituminous material away from storm drain inlets.
- Apply concrete, asphalt, and seal coat during dry weather to prevent contamination from contacting stormwater runoff.
- Cover and seal nearby storm drain inlets (with waterproof material or mesh) and manholes before applying seal coat, slurry seal, etc., where applicable. Leave covers in place until job is complete and until all water from emulsified oil sealants has drained or evaporated. Clean any debris from these covered manholes and drains for proper disposal.

# **Parking/Storage Area Maintenance SC-43**

---

- Use only as much water as necessary for dust control, to avoid runoff.
- Catch drips from paving equipment that is not in use with pans or absorbent material placed under the machines. Dispose of collected material and absorbents properly.

## *Inspection*

- Have designated personnel conduct inspections of the parking facilities and stormwater conveyance systems associated with them on a regular basis.
- Inspect cleaning equipment/sweepers for leaks on a regular basis.

## *Training*

- Provide regular training to field employees and/or contractors regarding cleaning of paved areas and proper operation of equipment.
- Train employees and contractors in proper techniques for spill containment and cleanup.

## *Spill Response and Prevention*

- Refer to SC-11, Spill Prevention, Control & Cleanup.
- Keep your Spill Prevention Control and countermeasure (SPCC) plan up-to-date, and implement accordingly.
- Have spill cleanup materials readily available and in a known location.
- Cleanup spills immediately and use dry methods if possible.
- Properly dispose of spill cleanup material.

## *Other Considerations*

- Limitations related to sweeping activities at large parking facilities may include high equipment costs, the need for sweeper operator training, and the inability of current sweeper technology to remove oil and grease.

## **Requirements**

### **Costs**

Cleaning/sweeping costs can be quite large, construction and maintenance of stormwater structural controls can be quite expensive as well.

### **Maintenance**

- Sweep parking lot to minimize cleaning with water.
- Clean out oil/water/sand separators regularly, especially after heavy storms.
- Clean parking facilities on a regular basis to prevent accumulated wastes and pollutants from being discharged into conveyance systems during rainy conditions.

# **SC-43 Parking/Storage Area Maintenance**

---

## **Supplemental Information**

### ***Further Detail of the BMP***

#### *Surface Repair*

Apply concrete, asphalt, and seal coat during dry weather to prevent contamination from contacting stormwater runoff. Where applicable, cover and seal nearby storm drain inlets (with waterproof material or mesh) and manholes before applying seal coat, slurry seal, etc. Leave covers in place until job is complete and until all water from emulsified oil sealants has drained or evaporated. Clean any debris from these covered manholes and drains for proper disposal. Use only as much water as necessary for dust control, to avoid runoff.

## **References and Resources**

<http://www.stormwatercenter.net/>

California's Nonpoint Source Program Plan <http://www.swrcb.ca.gov/nps/index.html>

Model Urban Runoff Program: A How-To Guide for Developing Urban Runoff Programs for Small Municipalities. Prepared by City of Monterey, City of Santa Cruz, California Coastal Commission, Monterey Bay National Marine Sanctuary, Association of Monterey Bay Area Governments, Woodward-Clyde, Central Coast Regional Water Quality control Board. July 1998 (Revised February 2002 by the California Coastal Commission).

Orange County Stormwater Program

[http://www.ocwatersheds.com/StormWater/swp\\_introduction.asp](http://www.ocwatersheds.com/StormWater/swp_introduction.asp)

Oregon Association of Clean Water Agencies. Oregon Municipal Stormwater Toolbox for Maintenance Practices. June 1998.

Pollution from Surface Cleaning Folder. 1996. Bay Area Stormwater Management Agencies Association (BASMAA) <http://www.basma.org>

San Diego Stormwater Co-permittees Jurisdictional Urban Runoff Management Program (URMP)

<http://www.projectcleanwater.org/pdf/Model%20Program%20Municipal%20Facilities.pdf>

## Description

Promote efficient and safe housekeeping practices (storage, use, and cleanup) when handling potentially harmful materials such as fertilizers, pesticides, cleaning solutions, paint products, automotive products, and swimming pool chemicals. Related information is provided in BMP fact sheets SC-11 Spill Prevention, Control & Cleanup and SC-34 Waste Handling & Disposal.

## Approach

### *Pollution Prevention*

- Purchase only the amount of material that will be needed for foreseeable use. In most cases this will result in cost savings in both purchasing and disposal. See SC-61 Safer Alternative Products for additional information.
- Be aware of new products that may do the same job with less environmental risk and for less or the equivalent cost. Total cost must be used here; this includes purchase price, transportation costs, storage costs, use related costs, clean up costs and disposal costs.

### *Suggested Protocols*

#### *General*

- Keep work sites clean and orderly. Remove debris in a timely fashion. Sweep the area.
- Dispose of wash water, sweepings, and sediments, properly.
- Recycle or dispose of fluids properly.
- Establish a daily checklist of office, yard and plant areas to confirm cleanliness and adherence to proper storage and security. Specific employees should be assigned specific inspection responsibilities and given the authority to remedy any problems found.
- Post waste disposal charts in appropriate locations detailing for each waste its hazardous nature (poison, corrosive, flammable), prohibitions on its disposal (dumpster, drain, sewer) and the recommended disposal method (recycle, sewer, burn, storage, landfill).
- Summarize the chosen BMPs applicable to your operation and post them in appropriate conspicuous places.

## Objectives

- Cover
- Contain
- Educate
- Reduce/Minimize
- Product Substitution

## Targeted Constituents

Sediment	<input checked="" type="checkbox"/>
Nutrients	<input checked="" type="checkbox"/>
Trash	<input checked="" type="checkbox"/>
Metals	<input checked="" type="checkbox"/>
Bacteria	<input checked="" type="checkbox"/>
Oil and Grease	<input checked="" type="checkbox"/>
Organics	<input checked="" type="checkbox"/>
Oxygen Demanding	<input checked="" type="checkbox"/>



- Require a signed checklist from every user of any hazardous material detailing amount taken, amount used, amount returned and disposal of spent material.
- Do a before audit of your site to establish baseline conditions and regular subsequent audits to note any changes and whether conditions are improving or deteriorating.
- Keep records of water, air and solid waste quantities and quality tests and their disposition.
- Maintain a mass balance of incoming, outgoing and on hand materials so you know when there are unknown losses that need to be tracked down and accounted for.
- Use and reward employee suggestions related to BMPs, hazards, pollution reduction, work place safety, cost reduction, alternative materials and procedures, recycling and disposal.
- Have, and review regularly, a contingency plan for spills, leaks, weather extremes etc. Make sure all employees know about it and what their role is so that it comes into force automatically.

***Training***

- Train all employees, management, office, yard, manufacturing, field and clerical in BMPs and pollution prevention and make them accountable.
- Train municipal employees who handle potentially harmful materials in good housekeeping practices.
- Train personnel who use pesticides in the proper use of the pesticides. The California Department of Pesticide Regulation license pesticide dealers, certify pesticide applicators and conduct onsite inspections.
- Train employees and contractors in proper techniques for spill containment and cleanup. The employee should have the tools and knowledge to immediately begin cleaning up a spill if one should occur.

***Spill Response and Prevention***

- Refer to SC-11, Spill Prevention, Control & Cleanup.
- Keep your Spill Prevention Control and Countermeasure (SPCC) plan up-to-date, and implement accordingly.
- Have spill cleanup materials readily available and in a known location.
- Cleanup spills immediately and use dry methods if possible.
- Properly dispose of spill cleanup material.

***Other Considerations***

- There are no major limitations to this best management practice.
- There are no regulatory requirements to this BMP. Existing regulations already require municipalities to properly store, use, and dispose of hazardous materials

## Requirements

### *Costs*

- Minimal cost associated with this BMP. Implementation of good housekeeping practices may result in cost savings as these procedures may reduce the need for more costly BMPs.

### *Maintenance*

- Ongoing maintenance required to keep a clean site. Level of effort is a function of site size and type of activities.

## Supplemental Information

### *Further Detail of the BMP*

- The California Integrated Waste Management Board's Recycling Hotline, 1-800-553-2962, provides information on household hazardous waste collection programs and facilities.

### *Examples*

There are a number of communities with effective programs. The most pro-active include Santa Clara County and the City of Palo Alto, the City and County of San Francisco, and the Municipality of Metropolitan Seattle (Metro).

## References and Resources

British Columbia Lake Stewardship Society. Best Management Practices to Protect Water Quality from Non-Point Source Pollution. March 2000.

<http://www.nalms.org/bclss/bmphome.html#bmp>

King County Stormwater Pollution Control Manual - <http://dnr.metrokc.gov/wlr/dss/spcm.htm>

Model Urban Runoff Program: A How-To Guide for Developing Urban Runoff Programs for Small Municipalities, Prepared by City of Monterey, City of Santa Cruz, California Coastal Commission, Monterey Bay National Marine Sanctuary, Association of Monterey Bay Area Governments, Woodward-Clyde, Central Coast Regional Water Quality Control Board. July, 1998, Revised by California Coastal Commission, February 2002.

Orange County Stormwater Program

[http://www.ocwatersheds.com/stormwater/swp\\_introduction.asp](http://www.ocwatersheds.com/stormwater/swp_introduction.asp)

San Mateo STOPPP - (<http://stoppp.tripod.com/bmp.html>)



## Objectives

- Cover
- Contain
- Educate
- Reduce/Minimize
- Product Substitution

## Description

Pollutants on sidewalks and other pedestrian traffic areas and plazas are typically due to littering and vehicle use. This fact sheet describes good housekeeping practices that can be incorporated into the municipality's existing cleaning and maintenance program.

## Approach

### *Pollution Prevention*

- Use dry cleaning methods whenever practical for surface cleaning activities.
- Use the least toxic materials available (e.g. water based paints, gels or sprays for graffiti removal).

### *Suggested Protocols*

#### *Surface Cleaning*

- Regularly broom (dry) sweep sidewalk, plaza and parking lot areas to minimize cleaning with water.
- Dry cleanup first (sweep, collect, and dispose of debris and trash) when cleaning sidewalks or plazas, then wash with or without soap.
- Block the storm drain or contain runoff when cleaning with water. Discharge wash water to landscaping or collect water and pump to a tank or discharge to sanitary sewer if allowed. (Permission may be required from local sanitation district.)

## Targeted Constituents

Sediment	<input checked="" type="checkbox"/>
Nutrients	<input checked="" type="checkbox"/>
Trash	<input checked="" type="checkbox"/>
Metals	<input checked="" type="checkbox"/>
Bacteria	<input checked="" type="checkbox"/>
Oil and Grease	<input checked="" type="checkbox"/>
Organics	<input checked="" type="checkbox"/>
Oxygen Demanding	<input checked="" type="checkbox"/>



- Block the storm drain or contain runoff when washing parking areas, driveways or drive-throughs. Use absorbents to pick up oil; then dry sweep. Clean with or without soap. Collect water and pump to a tank or discharge to sanitary sewer if allowed. Street Repair and Maintenance.

#### *Graffiti Removal*

- Avoid graffiti abatement activities during rain events.
- Implement the procedures under Painting and Paint Removal in SC-70 Roads, Streets, and Highway Operation and Maintenance fact sheet when graffiti is removed by painting over.
- Direct runoff from sand blasting and high pressure washing (with no cleaning agents) into a dirt or landscaped area after treating with an appropriate filtering device.
- Plug nearby storm drain inlets and vacuum/pump wash water to the sanitary sewer if authorized to do so if a graffiti abatement method generates wash water containing a cleaning compound (such as high pressure washing with a cleaning compound). Ensure that a non-hazardous cleaning compound is used or dispose as hazardous waste, as appropriate.

#### *Surface Removal and Repair*

- Schedule surface removal activities for dry weather if possible.
- Avoid creating excess dust when breaking asphalt or concrete.
- Take measures to protect nearby storm drain inlets prior to breaking up asphalt or concrete (e.g. place hay bales or sand bags around inlets). Clean afterwards by sweeping up as much material as possible.
- Designate an area for clean up and proper disposal of excess materials.
- Remove and recycle as much of the broken pavement as possible to avoid contact with rainfall and stormwater runoff.
- When making saw cuts in pavement, use as little water as possible. Cover each storm drain inlet completely with filter fabric during the sawing operation and contain the slurry by placing straw bales, sandbags, or gravel dams around the inlets. After the liquid drains or evaporates, shovel or vacuum the slurry residue from the pavement or gutter and remove from site.
- Always dry sweep first to clean up tracked dirt. Use a street sweeper or vacuum truck. Do not dump vacuumed liquid in storm drains. Once dry sweeping is complete, the area may be hosed down if needed. Wash water should be directed to landscaping or collected and pumped to the sanitary sewer if allowed.

#### *Concrete Installation and Repair*

- Schedule asphalt and concrete activities for dry weather.

- Take measures to protect any nearby storm drain inlets and adjacent watercourses, prior to breaking up asphalt or concrete (e.g. place sand bags around inlets or work areas).
- Limit the amount of fresh concrete or cement mortar mixed, mix only what is needed for the job.
- Store concrete materials under cover, away from drainage areas. Secure bags of cement after they are open. Be sure to keep wind-blown cement powder away from streets, gutters, storm drains, rainfall, and runoff.
- Return leftover materials to the transit mixer. Dispose of small amounts of hardened excess concrete, grout, and mortar in the trash.
- Do not wash sweepings from exposed aggregate concrete into the street or storm drain. Collect and return sweepings to aggregate base stockpile, or dispose in the trash.
- Protect applications of fresh concrete from rainfall and runoff until the material has dried.
- Do not allow excess concrete to be dumped onsite, except in designated areas.
- Wash concrete trucks off site or in designated areas on site designed to preclude discharge of wash water to drainage system.

## *Controlling Litter*

- Post “No Littering” signs and enforce anti-litter laws.
- Provide litter receptacles in busy, high pedestrian traffic areas of the community, at recreational facilities, and at community events.
- Cover litter receptacles and clean out frequently to prevent leaking/spillage or overflow.
- Clean parking lots on a regular basis with a street sweeper.

## *Training*

- Provide regular training to field employees and/or contractors regarding surface cleaning and proper operation of equipment.
- Train employee and contractors in proper techniques for spill containment and cleanup.
- Use a training log or similar method to document training.

## *Spill Response and Prevention*

- Refer to SC-11, Spill Prevention, Control & Cleanup.
- Have spill cleanup materials readily available and in a known location.
- Cleanup spills immediately and use dry methods if possible.
- Properly dispose of spill cleanup material.

***Other Considerations***

- Limitations related to sweeping activities at large parking facilities may include current sweeper technology to remove oil and grease.
- Surface cleaning activities that require discharges to the local sewerage agency will require coordination with the agency.
- Arrangements for disposal of the swept material collected must be made, as well as accurate tracking of the areas swept and the frequency of sweeping

**Requirements*****Costs***

- The largest expenditures for sweeping and cleaning of sidewalks, plazas, and parking lots are in staffing and equipment. Sweeping of these areas should be incorporated into street sweeping programs to reduce costs.

***Maintenance***

Not applicable

**Supplemental Information*****Further Detail of the BMP***

Community education, such as informing residents about their options for recycling and waste disposal, as well as the consequences of littering, can instill a sense of citizen responsibility and potentially reduce the amount of maintenance required by the municipality.

Additional BMPs that should be considered for parking lot areas include:

- Allow sheet runoff to flow into biofilters (vegetated strip and swale) and infiltration devices.
- Utilize sand filters or oleophilic collectors for oily waste in low concentrations.
- Arrange rooftop drains to prevent drainage directly onto paved surfaces.
- Design lot to include semi-permeable hardscape.
- Structural BMPs such as storm drain inlet filters can be very effective in reducing the amount of pollutants discharged from parking facilities during periods of rain.

**References and Resources**

Bay Area Stormwater Management Agencies Association (BASMAA). 1996. Pollution From Surface Cleaning Folder <http://www.basmaa.org>

Model Urban Runoff Program: A How-To Guide for Developing Urban Runoff Programs for Small Municipalities. Prepared by City of Monterey, City of Santa Cruz, California Coastal Commission, Monterey Bay National Marine Sanctuary, Association of Monterey Bay Area Governments, Woodward-Clyde, Central Coast Regional Water Quality Control Board. July. 1998.

Oregon Association of Clean Water Agencies. Oregon Municipal Stormwater Toolbox for Maintenance Practices. June 1998.

Orange County Stormwater Program

[http://www.ocwatersheds.com/stormwater/swp\\_introduction.asp](http://www.ocwatersheds.com/stormwater/swp_introduction.asp)

Santa Clara Valley Urban Runoff Pollution Prevention Program. 1997 Urban Runoff Management Plan. September 1997, updated October 2000.

Santa Clara Valley Urban Runoff Pollution Prevention Program. Maintenance Best Management Practices for the Construction Industry. Brochures: Landscaping, Gardening, and Pool; Roadwork and Paving; and Fresh Concrete and Mortar Application. June 2001.

San Diego Stormwater Co-permittees Jurisdictional Urban Runoff Management Plan. 2001. Municipal Activities Model Program Guidance. November.



## Objectives

- Contain
- Educate
- Reduce/Minimize
- Product Substitution

## Targeted Constituents

Sediment	<input checked="" type="checkbox"/>
Nutrients	<input checked="" type="checkbox"/>
Trash	<input checked="" type="checkbox"/>
Metals	
Bacteria	
Oil and Grease	
Organics	
Oxygen Demanding	<input checked="" type="checkbox"/>

## Description

Landscape maintenance activities include vegetation removal; herbicide and insecticide application; fertilizer application; watering; and other gardening and lawn care practices. Vegetation control typically involves a combination of chemical (herbicide) application and mechanical methods. All of these maintenance practices have the potential to contribute pollutants to the storm drain system. The major objectives of this BMP are to minimize the discharge of pesticides, herbicides and fertilizers to the storm drain system and receiving waters; prevent the disposal of landscape waste into the storm drain system by collecting and properly disposing of clippings and cuttings, and educating employees and the public.

## Approach

### *Pollution Prevention*

- Implement an integrated pest management (IPM) program. IPM is a sustainable approach to managing pests by combining biological, cultural, physical, and chemical tools.
- Choose low water using flowers, trees, shrubs, and groundcover.
- Consider alternative landscaping techniques such as naturescaping and xeriscaping.
- Conduct appropriate maintenance (i.e. properly timed fertilizing, weeding, pest control, and pruning) to help preserve the landscapes water efficiency.



- Consider grass cycling (grass cycling is the natural recycling of grass by leaving the clippings on the lawn when mowing. Grass clippings decompose quickly and release valuable nutrients back into the lawn).

## ***Suggested Protocols***

### *Mowing, Trimming, and Weeding*

- Whenever possible use mechanical methods of vegetation removal (e.g mowing with tractor-type or push mowers, hand cutting with gas or electric powered weed trimmers) rather than applying herbicides. Use hand weeding where practical.
- Avoid loosening the soil when conducting mechanical or manual weed control, this could lead to erosion. Use mulch or other erosion control measures when soils are exposed.
- Performing mowing at optimal times. Mowing should not be performed if significant rain events are predicted.
- Mulching mowers may be recommended for certain flat areas. Other techniques may be employed to minimize mowing such as selective vegetative planting using low maintenance grasses and shrubs.
- Collect lawn and garden clippings, pruning waste, tree trimmings, and weeds. Chip if necessary, and compost or dispose of at a landfill (see waste management section of this fact sheet).
- Place temporarily stockpiled material away from watercourses, and berm or cover stockpiles to prevent material releases to storm drains.

### ***Planting***

- Determine existing native vegetation features (location, species, size, function, importance) and consider the feasibility of protecting them. Consider elements such as their effect on drainage and erosion, hardiness, maintenance requirements, and possible conflicts between preserving vegetation and the resulting maintenance needs.
- Retain and/or plant selected native vegetation whose features are determined to be beneficial, where feasible. Native vegetation usually requires less maintenance (e.g., irrigation, fertilizer) than planting new vegetation.
- Consider using low water use groundcovers when planting or replanting.

### ***Waste Management***

- Compost leaves, sticks, or other collected vegetation or dispose of at a permitted landfill. Do not dispose of collected vegetation into waterways or storm drainage systems.
- Place temporarily stockpiled material away from watercourses and storm drain inlets, and berm or cover stockpiles to prevent material releases to the storm drain system.
- Reduce the use of high nitrogen fertilizers that produce excess growth requiring more frequent mowing or trimming.

- Avoid landscape wastes in and around storm drain inlets by either using bagging equipment or by manually picking up the material.

## ***Irrigation***

- Where practical, use automatic timers to minimize runoff.
- Use popup sprinkler heads in areas with a lot of activity or where there is a chance the pipes may be broken. Consider the use of mechanisms that reduce water flow to sprinkler heads if broken.
- Ensure that there is no runoff from the landscaped area(s) if re-claimed water is used for irrigation.
- If bailing of muddy water is required (e.g. when repairing a water line leak), do not put it in the storm drain; pour over landscaped areas.
- Irrigate slowly or pulse irrigate to prevent runoff and then only irrigate as much as is needed.
- Apply water at rates that do not exceed the infiltration rate of the soil.

## ***Fertilizer and Pesticide Management***

- Utilize a comprehensive management system that incorporates integrated pest management (IPM) techniques. There are many methods and types of IPM, including the following:
  - Mulching can be used to prevent weeds where turf is absent, fencing installed to keep rodents out, and netting used to keep birds and insects away from leaves and fruit.
  - Visible insects can be removed by hand (with gloves or tweezers) and placed in soapy water or vegetable oil. Alternatively, insects can be sprayed off the plant with water or in some cases vacuumed off of larger plants.
  - Store-bought traps, such as species-specific, pheromone-based traps or colored sticky cards, can be used.
  - Slugs can be trapped in small cups filled with beer that are set in the ground so the slugs can get in easily.
  - In cases where microscopic parasites, such as bacteria and fungi, are causing damage to plants, the affected plant material can be removed and disposed of (pruning equipment should be disinfected with bleach to prevent spreading the disease organism).
  - Small mammals and birds can be excluded using fences, netting, tree trunk guards.
  - Beneficial organisms, such as bats, birds, green lacewings, ladybugs, praying mantis, ground beetles, parasitic nematodes, trichogramma wasps, seed head weevils, and spiders that prey on detrimental pest species can be promoted.
- Follow all federal, state, and local laws and regulations governing the use, storage, and disposal of fertilizers and pesticides and training of applicators and pest control advisors.

- Use pesticides only if there is an actual pest problem (not on a regular preventative schedule).
- Do not use pesticides if rain is expected. Apply pesticides only when wind speeds are low (less than 5 mph).
- Do not mix or prepare pesticides for application near storm drains.
- Prepare the minimum amount of pesticide needed for the job and use the lowest rate that will effectively control the pest.
- Employ techniques to minimize off-target application (e.g. spray drift) of pesticides, including consideration of alternative application techniques.
- Fertilizers should be worked into the soil rather than dumped or broadcast onto the surface.
- Calibrate fertilizer and pesticide application equipment to avoid excessive application.
- Periodically test soils for determining proper fertilizer use.
- Sweep pavement and sidewalk if fertilizer is spilled on these surfaces before applying irrigation water.
- Purchase only the amount of pesticide that you can reasonably use in a given time period (month or year depending on the product).
- Triple rinse containers, and use rinse water as product. Dispose of unused pesticide as hazardous waste.
- Dispose of empty pesticide containers according to the instructions on the container label.

### *Inspection*

- Inspect irrigation system periodically to ensure that the right amount of water is being applied and that excessive runoff is not occurring. Minimize excess watering, and repair leaks in the irrigation system as soon as they are observed.
- Inspect pesticide/fertilizer equipment and transportation vehicles daily.

### *Training*

- Educate and train employees on use of pesticides and in pesticide application techniques to prevent pollution. Pesticide application must be under the supervision of a California qualified pesticide applicator.
- Train/encourage municipal maintenance crews to use IPM techniques for managing public green areas.
- Annually train employees within departments responsible for pesticide application on the appropriate portions of the agency's IPM Policy, SOPs, and BMPs, and the latest IPM techniques.

- Employees who are not authorized and trained to apply pesticides should be periodically (at least annually) informed that they cannot use over-the-counter pesticides in or around the workplace.
- Use a training log or similar method to document training.

### ***Spill Response and Prevention***

- Refer to SC-11, Spill Prevention, Control & Cleanup
- Have spill cleanup materials readily available and in a known location
- Cleanup spills immediately and use dry methods if possible.
- Properly dispose of spill cleanup material.

### ***Other Considerations***

- The Federal Pesticide, Fungicide, and Rodenticide Act and California Title 3, Division 6, Pesticides and Pest Control Operations place strict controls over pesticide application and handling and specify training, annual refresher, and testing requirements. The regulations generally cover: a list of approved pesticides and selected uses, updated regularly; general application information; equipment use and maintenance procedures; and record keeping. The California Department of Pesticide Regulations and the County Agricultural Commission coordinate and maintain the licensing and certification programs. All public agency employees who apply pesticides and herbicides in “agricultural use” areas such as parks, golf courses, rights-of-way and recreation areas should be properly certified in accordance with state regulations. Contracts for landscape maintenance should include similar requirements.
- All employees who handle pesticides should be familiar with the most recent material safety data sheet (MSDS) files.
- Municipalities do not have the authority to regulate the use of pesticides by school districts, however the California Healthy Schools Act of 2000 (AB 2260) has imposed requirements on California school districts regarding pesticide use in schools. Posting of notification prior to the application of pesticides is now required, and IPM is stated as the preferred approach to pest management in schools.

## **Requirements**

### ***Costs***

Additional training of municipal employees will be required to address IPM techniques and BMPs. IPM methods will likely increase labor cost for pest control which may be offset by lower chemical costs.

### ***Maintenance***

Not applicable

## Supplemental Information

### *Further Detail of the BMP*

#### *Waste Management*

Composting is one of the better disposal alternatives if locally available. Most municipalities either have or are planning yard waste composting facilities as a means of reducing the amount of waste going to the landfill. Lawn clippings from municipal maintenance programs as well as private sources would probably be compatible with most composting facilities

#### *Contractors and Other Pesticide Users*

Municipal agencies should develop and implement a process to ensure that any contractor employed to conduct pest control and pesticide application on municipal property engages in pest control methods consistent with the IPM Policy adopted by the agency. Specifically, municipalities should require contractors to follow the agency's IPM policy, SOPs, and BMPs; provide evidence to the agency of having received training on current IPM techniques when feasible; provide documentation of pesticide use on agency property to the agency in a timely manner.

## References and Resources

King County Stormwater Pollution Control Manual. Best Management Practices for Businesses. 1995. King County Surface Water Management. July. On-line: <http://dnr.metrokc.gov/wlr/dss/spcm.htm>

Los Angeles County Stormwater Quality Model Programs. Public Agency Activities [http://ladpw.org/wmd/npdes/model\\_links.cfm](http://ladpw.org/wmd/npdes/model_links.cfm)

Model Urban Runoff Program: A How-To Guide for Developing Urban Runoff Programs for Small Municipalities. Prepared by City of Monterey, City of Santa Cruz, California Coastal Commission, Monterey Bay National Marine Sanctuary, Association of Monterey Bay Area Governments, Woodward-Clyde, Central Coast Regional Water Quality Control Board. July. 1998.

Orange County Stormwater Program

[http://www.ocwatersheds.com/StormWater/swp\\_introduction.asp](http://www.ocwatersheds.com/StormWater/swp_introduction.asp)

Santa Clara Valley Urban Runoff Pollution Prevention Program. 1997 Urban Runoff Management Plan. September 1997, updated October 2000.

United States Environmental Protection Agency (USEPA). 2002. Pollution Prevention/Good Housekeeping for Municipal Operations Landscaping and Lawn Care. Office of Water. Office of Wastewater Management. On-line: [http://www.epa.gov/npdes/menuofbmps/poll\\_8.htm](http://www.epa.gov/npdes/menuofbmps/poll_8.htm)



Photo Credit: Geoff Brosseau

## Objectives

- Contain
- Educate
- Reduce/Minimize

## Description

As a consequence of its function, the stormwater conveyance system collects and transports urban runoff that may contain certain pollutants. Maintaining catch basins, stormwater inlets, and other stormwater conveyance structures on a regular basis will remove pollutants, prevent clogging of the downstream conveyance system, restore catch basins' sediment trapping capacity, and ensure the system functions properly hydraulically to avoid flooding.

## Approach

### *Suggested Protocols*

#### *Catch Basins/Inlet Structures*

- Municipal staff should regularly inspect facilities to ensure the following:
  - Immediate repair of any deterioration threatening structural integrity.
  - Cleaning before the sump is 40% full. Catch basins should be cleaned as frequently as needed to meet this standard.
  - Stenciling of catch basins and inlets (see SC-75 Waste Handling and Disposal).
- Clean catch basins, storm drain inlets, and other conveyance structures in high pollutant load areas just before the wet season to remove sediments and debris accumulated during the summer.

## Targeted Constituents

Sediment	<input checked="" type="checkbox"/>
Nutrients	<input checked="" type="checkbox"/>
Trash	<input checked="" type="checkbox"/>
Metals	<input checked="" type="checkbox"/>
Bacteria	<input checked="" type="checkbox"/>
Oil and Grease	<input checked="" type="checkbox"/>
Organics	<input checked="" type="checkbox"/>
Oxygen Demanding	<input checked="" type="checkbox"/>



- Conduct inspections more frequently during the wet season for problem areas where sediment or trash accumulates more often. Clean and repair as needed.
- Keep accurate logs of the number of catch basins cleaned.
- Record the amount of waste collected.
- Store wastes collected from cleaning activities of the drainage system in appropriate containers or temporary storage sites in a manner that prevents discharge to the storm drain.
- Dewater the wastes with outflow into the sanitary sewer if permitted. Water should be treated with an appropriate filtering device prior to discharge to the sanitary sewer. If discharge to the sanitary sewer is not allowed, water should be pumped or vacuumed to a tank and properly disposed of. Do not dewater near a storm drain or stream.
- Except for small communities with relatively few catch basins that may be cleaned manually, most municipalities will require mechanical cleaners such as eductors, vacuums, or bucket loaders.

#### *Storm Drain Conveyance System*

- Locate reaches of storm drain with deposit problems and develop a flushing schedule that keeps the pipe clear of excessive buildup.
- Collect flushed effluent and pump to the sanitary sewer for treatment.

#### *Pump Stations*

- Clean all storm drain pump stations prior to the wet season to remove silt and trash.
- Do not allow discharge from cleaning a storm drain pump station or other facility to reach the storm drain system.
- Conduct quarterly routine maintenance at each pump station.
- Inspect, clean, and repair as necessary all outlet structures prior to the wet season.
- Sample collected sediments to determine if landfill disposal is possible, or illegal discharges in the watershed are occurring.

#### *Open Channel*

- Consider modification of storm channel characteristics to improve channel hydraulics, to increase pollutant removals, and to enhance channel/creek aesthetic and habitat value.
- Conduct channel modification/improvement in accordance with existing laws. Any person, government agency, or public utility proposing an activity that will change the natural (emphasis added) state of any river, stream, or lake in California, must enter into a stream or Lake Alteration Agreement with the Department of Fish and Game. The developer-applicant should also contact local governments (city, county, special districts), other state agencies

(SWRCB, RWQCB, Department of Forestry, Department of Water Resources), and Federal Corps of Engineers and USFWS

## *Illicit Connections and Discharges*

- During routine maintenance of conveyance system and drainage structures field staff should look for evidence of illegal discharges or illicit connections:
  - Is there evidence of spills such as paints, discoloring, etc.
  - Are there any odors associated with the drainage system
  - Record locations of apparent illegal discharges/illicit connections
  - Track flows back to potential dischargers and conduct aboveground inspections. This can be done through visual inspection of up gradient manholes or alternate techniques including zinc chloride smoke testing, fluorometric dye testing, physical inspection testing, or television camera inspection.
  - Once the origin of flow is established, require illicit discharger to eliminate the discharge.
- Stencil storm drains, where applicable, to prevent illegal disposal of pollutants. Storm drain inlets should have messages such as “Dump No Waste Drains to Stream” stenciled next to them to warn against ignorant or intentional dumping of pollutants into the storm drainage system.
- Refer to fact sheet SC-10 Non-Stormwater Discharges.

## *Illegal Dumping*

- Regularly inspect and clean up hot spots and other storm drainage areas where illegal dumping and disposal occurs.
- Establish a system for tracking incidents. The system should be designed to identify the following:
  - Illegal dumping hot spots
  - Types and quantities (in some cases) of wastes
  - Patterns in time of occurrence (time of day/night, month, or year)
  - Mode of dumping (abandoned containers, “midnight dumping” from moving vehicles, direct dumping of materials, accidents/spills)
  - Responsible parties
- Post “No Dumping” signs in problem areas with a phone number for reporting dumping and disposal. Signs should also indicate fines and penalties for illegal dumping.
- Refer to fact sheet SC-10 Non-Stormwater Discharges.

# SC-74      Drainage System Maintenance

---

- The State Department of Fish and Game has a hotline for reporting violations called Cal TIP (1-800-952-5400). The phone number may be used to report any violation of a Fish and Game code (illegal dumping, poaching, etc.).
- The California Department of Toxic Substances Control's Waste Alert Hotline, 1-800-69TOXIC, can be used to report hazardous waste violations.

## ***Training***

- Train crews in proper maintenance activities, including record keeping and disposal
- Only properly trained individuals are allowed to handle hazardous materials/wastes.
- Train municipal employees from all departments (public works, utilities, street cleaning, parks and recreation, industrial waste inspection, hazardous waste inspection, sewer maintenance) to recognize and report illegal dumping.
- Train municipal employees and educate businesses, contractors, and the general public in proper and consistent methods for disposal.
- Train municipal staff regarding non-stormwater discharges (See SC-10 Non-Stormwater Discharges).

## ***Spill Response and Prevention***

- Refer to SC-11, Prevention, Control & Cleanup
- Have spill cleanup materials readily available and in a known location.
- Cleanup spills immediately and use dry methods if possible.
- Properly dispose of spill cleanup material.

## ***Other Considerations***

- Cleanup activities may create a slight disturbance for local aquatic species. Access to items and material on private property may be limited. Trade-offs may exist between channel hydraulics and water quality/riparian habitat. If storm channels or basins are recognized as wetlands, many activities, including maintenance, may be subject to regulation and permitting.
- Storm drain flushing is most effective in small diameter pipes (36-inch diameter pipe or less, depending on water supply and sediment collection capacity). Other considerations associated with storm drain flushing may include the availability of a water source, finding a downstream area to collect sediments, liquid/sediment disposal, and disposal of flushed effluent to sanitary sewer may be prohibited in some areas.
- Regulations may include adoption of substantial penalties for illegal dumping and disposal.
- Municipal codes should include sections prohibiting the discharge of soil, debris, refuse, hazardous wastes, and other pollutants into the storm drain system.
- Private property access rights may be needed to track illegal discharges up gradient.

- Requirements of municipal ordinance authority for suspected source verification testing for illicit connections necessary for guaranteed rights of entry.

## Requirements

### Costs

- An aggressive catch basin cleaning program could require a significant capital and O&M budget. A careful study of cleaning effectiveness should be undertaken before increased cleaning is implemented. Catch basin cleaning costs are less expensive if vacuum street sweepers are available; cleaning catch basins manually can cost approximately twice as much as cleaning the basins with a vacuum attached to a sweeper.
- Methods used for illicit connection detection (smoke testing, dye testing, visual inspection, and flow monitoring) can be costly and time-consuming. Site-specific factors, such as the level of impervious area, the density and ages of buildings, and type of land use will determine the level of investigation necessary. Encouraging reporting of illicit discharges by employees can offset costs by saving expense on inspectors and directing resources more efficiently. Some programs have used funds available from “environmental fees” or special assessment districts to fund their illicit connection elimination programs.

### Maintenance

- Two-person teams may be required to clean catch basins with vector trucks.
- Identifying illicit discharges requires teams of at least two people (volunteers can be used), plus administrative personnel, depending on the complexity of the storm sewer system.
- Arrangements must be made for proper disposal of collected wastes.
- Requires technical staff to detect and investigate illegal dumping violations, and to coordinate public education.

## Supplemental Information

### Further Detail of the BMP

#### *Storm Drain flushing*

Sanitary sewer flushing is a common maintenance activity used to improve pipe hydraulics and to remove pollutants in sanitary sewer systems. The same principles that make sanitary sewer flushing effective can be used to flush storm drains. Flushing may be designed to hydraulically convey accumulated material to strategic locations, such as to an open channel, to another point where flushing will be initiated, or over to the sanitary sewer and on to the treatment facilities, thus preventing re-suspension and overflow of a portion of the solids during storm events. Flushing prevents “plug flow” discharges of concentrated pollutant loadings and sediments. The deposits can hinder the designed conveyance capacity of the storm drain system and potentially cause backwater conditions in severe cases of clogging.

Storm drain flushing usually takes place along segments of pipe with grades that are too flat to maintain adequate velocity to keep particles in suspension. An upstream manhole is selected to place an inflatable device that temporarily plugs the pipe. Further upstream, water is pumped into the line to create a flushing wave. When the upstream reach of pipe is sufficiently full to

cause a flushing wave, the inflated device is rapidly deflated with the assistance of a vacuum pump, releasing the backed up water and resulting in the cleaning of the storm drain segment.

To further reduce the impacts of stormwater pollution, a second inflatable device, placed well downstream, may be used to re-collect the water after the force of the flushing wave has dissipated. A pump may then be used to transfer the water and accumulated material to the sanitary sewer for treatment. In some cases, an interceptor structure may be more practical or required to re-collect the flushed waters.

It has been found that cleansing efficiency of periodic flush waves is dependent upon flush volume, flush discharge rate, sewer slope, sewer length, sewer flow rate, sewer diameter, and population density. As a rule of thumb, the length of line to be flushed should not exceed 700 feet. At this maximum recommended length, the percent removal efficiency ranges between 65-75 percent for organics and 55-65 percent for dry weather grit/inorganic material. The percent removal efficiency drops rapidly beyond that. Water is commonly supplied by a water truck, but fire hydrants can also supply water. To make the best use of water, it is recommended that reclaimed water be used or that fire hydrant line flushing coincide with storm drain flushing.

#### *Flow Management*

Flow management has been one of the principal motivations for designing urban stream corridors in the past. Such needs may or may not be compatible with the stormwater quality goals in the stream corridor.

Downstream flood peaks can be suppressed by reducing through flow velocity. This can be accomplished by reducing gradient with grade control structures or increasing roughness with boulders, dense vegetation, or complex banks forms. Reducing velocity correspondingly increases flood height, so all such measures have a natural association with floodplain open space. Flood elevations laterally adjacent to the stream can be lowered by increasing through flow velocity.

However, increasing velocity increases flooding downstream and inherently conflicts with channel stability and human safety. Where topography permits, another way to lower flood elevation is to lower the level of the floodway with drop structures into a large but subtly excavated bowl where flood flows were allowed to spread out.

#### *Stream Corridor Planning*

Urban streams receive and convey stormwater flows from developed or developing watersheds. Planning of stream corridors thus interacts with urban stormwater management programs. If local programs are intended to control or protect downstream environments by managing flows delivered to the channels, then it is logical that such programs should be supplemented by management of the materials, forms, and uses of the downstream riparian corridor. Any proposal for stream alteration or management should be investigated for its potential flow and stability effects on upstream, downstream, and laterally adjacent areas. The timing and rate of flow from various tributaries can combine in complex ways to alter flood hazards. Each section of channel is unique, influenced by its own distribution of roughness elements, management activities, and stream responses.

Flexibility to adapt to stream features and behaviors as they evolve must be included in stream reclamation planning. The amenity and ecology of streams may be enhanced through the landscape design options of 1) corridor reservation, 2) bank treatment, 3) geomorphic restoration, and 4) grade control.

Corridor reservation - Reserving stream corridors and valleys to accommodate natural stream meandering, aggradation, degradation, and over bank flows allows streams to find their own form and generate less ongoing erosion. In California, open stream corridors in recent urban developments have produced recreational open space, irrigation of streamside plantings, and the aesthetic amenity of flowing water.

Bank treatment - The use of armoring, vegetative cover, and flow deflection may be used to influence a channel's form, stability, and biotic habitat. To prevent bank erosion, armoring can be done with rigid construction materials, such as concrete, masonry, wood planks and logs, riprap, and gabions. Concrete linings have been criticized because of their lack of provision of biotic habitat. In contrast, riprap and gabions make relatively porous and flexible linings. Boulders, placed in the bed reduce velocity and erosive power.

Riparian vegetation can stabilize the banks of streams that are at or near a condition of equilibrium. Binding networks of roots increase bank shear strength. During flood flows, resilient vegetation is forced into erosion-inhibiting mats. The roughness of vegetation leads to lower velocity, further reducing erosive effects. Structural flow deflection can protect banks from erosion or alter fish habitat. By concentrating flow, a deflector causes a pool to be scoured in the bed.

Geomorphic restoration – Restoration refers to alteration of disturbed streams so their form and behavior emulate those of undisturbed streams. Natural meanders are retained, with grading to gentle slopes on the inside of curves to allow point bars and riffle-pool sequences to develop. Trees are retained to provide scenic quality, biotic productivity, and roots for bank stabilization, supplemented by plantings where necessary.

A restorative approach can be successful where the stream is already approaching equilibrium. However, if upstream urbanization continues new flow regimes will be generated that could disrupt the equilibrium of the treated system.

Grade Control - A grade control structure is a level shelf of a permanent material, such as stone, masonry, or concrete, over which stream water flows. A grade control structure is called a sill, weir, or drop structure, depending on the relation of its invert elevation to upstream and downstream channels.

A sill is installed at the preexisting channel bed elevation to prevent upstream migration of nick points. It establishes a firm base level below which the upstream channel can not erode.

A weir or check dam is installed with invert above the preexisting bed elevation. A weir raises the local base level of the stream and causes aggradation upstream. The gradient, velocity, and erosive potential of the stream channel are reduced. A drop structure lowers the downstream invert below its preexisting elevation, reducing downstream gradient and velocity. Weirs and drop structure control erosion by dissipating energy and reducing slope velocity.

When carefully applied, grade control structures can be highly versatile in establishing human and environmental benefits in stabilized channels. To be successful, application of grade control structures should be guided by analysis of the stream system both upstream and downstream from the area to be reclaimed.

**Examples**

The California Department of Water Resources began the Urban Stream Restoration Program in 1985. The program provides grant funds to municipalities and community groups to implement stream restoration projects. The projects reduce damages from streambank and watershed instability and floods while restoring streams' aesthetic, recreational, and fish and wildlife values.

In Buena Vista Park, upper floodway slopes are gentle and grassed to achieve continuity of usable park land across the channel of small boulders at the base of the slopes.

The San Diego River is a large, vegetative lined channel, which was planted in a variety of species to support riparian wildlife while stabilizing the steep banks of the floodway.

**References and Resources**

Ferguson, B.K. 1991. Urban Stream Reclamation, p. 324-322, *Journal of Soil and Water Conservation*.

Los Angeles County Stormwater Quality. Public Agency Activities Model Program. On-line: [http://ladpw.org/wmd/npdes/public\\_TC.cfm](http://ladpw.org/wmd/npdes/public_TC.cfm)

Model Urban Runoff Program: A How-To Guide for Developing Urban Runoff Programs for Small Municipalities. Prepared by City of Monterey, City of Santa Cruz, California Coastal Commission, Monterey Bay National Marine Sanctuary, Association of Monterey Bay Area Governments, Woodward-Clyde, Central Coast Regional Water Quality Control Board. July. 1998.

Orange County Stormwater Program

[http://www.ocwatersheds.com/StormWater/swp\\_introduction.asp](http://www.ocwatersheds.com/StormWater/swp_introduction.asp)

Santa Clara Valley Urban Runoff Pollution Prevention Program. 1997 Urban Runoff Management Plan. September 1997, updated October 2000.

San Diego Stormwater Co-permittees Jurisdictional Urban Runoff Management Program (URMP) Municipal Activities Model Program Guidance. 2001. Project Clean Water. November.

United States Environmental Protection Agency (USEPA). 1999. Stormwater Management Fact Sheet Non-stormwater Discharges to Storm Sewers. EPA 832-F-99-022. Office of Water, Washington, D.C. September.

United States Environmental Protection Agency (USEPA). 1999. Stormwater O&M Fact Sheet Catch Basin Cleaning. EPA 832-F-99-011. Office of Water, Washington, D.C. September.

United States Environmental Protection Agency (USEPA). 2002. Pollution Prevention/Good Housekeeping for Municipal Operations Illegal Dumping Control. On line:

[http://www.epa.gov/npdes/menuofbmps/poll\\_7.htm](http://www.epa.gov/npdes/menuofbmps/poll_7.htm)

United States Environmental Protection Agency (USEPA). 2002. Pollution Prevention/Good Housekeeping for Municipal Operations Storm Drain System Cleaning. On line:

[http://www.epa.gov/npdes/menuofbmps/poll\\_16.htm](http://www.epa.gov/npdes/menuofbmps/poll_16.htm)



## Objectives

- Cover
- Contain
- Educate
- Reduce/Reuse

## Description

It is important to control litter to eliminate trash and other materials in stormwater runoff. Waste reduction is a major component of waste management and should be encouraged through training and public outreach. Management of waste once it is collected may involve reuse, recycling, or proper disposal.

## Approach

### *Pollution Prevention*

- Reuse products when possible.
- Encourage recycling programs with recycling bins, used oil collection, etc.

### *Suggested Protocols*

#### *Solid Waste Collection*

- Implement procedures, where applicable, to collect, transport, and dispose of solid waste at appropriate disposal facilities in accordance with applicable federal, state, and local laws and regulations.
- Include properly designed trash storage areas. If feasible provide cover over trash storage areas.
- Regularly inspect solid waste containers for structural damage. Repair or replace damaged containers as necessary.

## Targeted Constituents

Sediment	<input checked="" type="checkbox"/>
Nutrients	<input checked="" type="checkbox"/>
Trash	<input checked="" type="checkbox"/>
Metals	<input checked="" type="checkbox"/>
Bacteria	<input checked="" type="checkbox"/>
Oil and Grease	<input checked="" type="checkbox"/>
Organics	<input checked="" type="checkbox"/>
Oxygen Demanding	<input checked="" type="checkbox"/>



- Secure solid waste containers; containers must be closed tightly when not in use.
- Do not fill waste containers with washout water or any other liquid.
- Ensure that only appropriate solid wastes are added to the solid waste container. Certain wastes such as hazardous wastes, appliances, fluorescent lamps, pesticides, etc. may not be disposed of in solid waste containers (see chemical/ hazardous waste collection section below).
- Do not mix wastes; this can cause chemical reactions, make recycling impossible, and complicate disposal.
- Refer to SC-34 Waste Handling and Disposal for more information regarding solid waste facilities.

#### *Waste Reduction and Recycling*

- Recycle wastes whenever possible. Many types of waste can be recycled, recycling options for each waste type are limited. All gasoline, antifreeze, waste oil, and lead-acid batteries can be recycled. Latex and oil-based paint can be reused, as well as recycled. Materials that cannot be reused or recycled should either be incinerated or disposed of at a properly permitted landfill.
- Recycling is always preferable to disposal of unwanted materials.
- Recycling bins for glass, metal, newspaper, plastic bottles and other recyclable household solid wastes should be provided at public facilities and/or for residential curbside collection.

#### *Controlling Litter*

- Post “No Littering” signs and enforce anti-litter laws.
- Provide litter receptacles in busy, high pedestrian traffic areas of the community, at recreational facilities, and at community events.
- Clean out and cover litter receptacles frequently to prevent spillage.

#### *Illegal Dumping*

Substances illegally dumped on streets and into the storm drain system and creeks include paints, used oil and other automotive fluids, construction debris, chemicals, fresh concrete, leaves, grass clipping, and pet wastes.

- Post “No Dumping” signs with a phone number for reporting dumping and disposal. Signs should also indicate fines and penalties for illegal dumping.
- Landscaping and beautification efforts of hot spots might also discourage future dumping.
- See SC-74 Drainage System Maintenance, and SC-10 Non-Stormwater Discharges.

## Requirements

### *Costs*

- The costs for a solid waste source control program vary depending on the type of method. The cost of a community education program or a plan to increase the number of trash receptacles can be very minimal. Costs for structural controls such as trash racks, bar screens, and silt traps can be quite costly ranging from \$250,000 to \$900,000.
- A collection facility or curbside collection for used oil may result in significant costs. Commercial locations (automobile service stations, quick oil change centers, etc.) as collection points eliminate hauling and recycling costs.
- Collection and disposal of hazardous waste can be very expensive and requires trained operators; laboratory and detection equipment; and extensive record keeping including dates, types, and quantities.
- Use of volunteer work forces can lower storm drain stenciling program costs. Stenciling kits require procurement of durable/disposable items. The stenciling program can aid in the cataloging of the storm drain system. One municipality from the state of Washington has estimated that stenciling kits cost approximately \$50 each. Stencils may cost about \$8 each including the die cost on an order of 1,000. Re-orders cost about \$1/stencil. Stencil designs may be available from other communities. Stencil kits should be provided on a loan basis to volunteer groups free of charge with the understanding that kit remnants are to be returned.

### *Maintenance*

- The primary staff demand for stenciling programs is for program setup to provide marketing and training. Ongoing/follow-up staff time is minimal because of volunteer services.
- Staffing requirements are minimal for oil recycling programs if collection/recycling is contracted out to a used oil hauler/recycler or required at commercial locations.
- Staff requirements for maintaining good housekeeping BMPs at waste handling sites is minimal.

## Supplemental Information

### *Further Detail of the BMP*

#### *Waste Reduction*

An approach to reduce stormwater pollution from waste handling and disposal is to assess activities and reduce waste generation. The assessment is designed to find situations where waste can be eliminated or reduced and emissions and environmental damage can be minimized. The assessment involves collecting process specific information, setting pollution prevention targets, and developing, screening and selecting waste reduction options for further study. Starting a waste reduction program is economically beneficial because of reduced raw material purchases and lower waste disposal fees.

**References and Resources**

Best Management Practices Program for Pollution Prevention, City and County of San Francisco, Uribe & Associates, Oakland, California, 1990.

Harvard University. 2002. Solid Waste Container Best Management Practices – Fact Sheet On-Line Resources – Environmental Health and Safety.

Model Urban Runoff Program: A How-To-Guide for Developing Urban Runoff Programs for Small Municipalities. Prepared by City of Monterey, City of Santa Cruz, California Coastal Commission, Monterey Bay National Marine Sanctuary, Association of Monterey Bay Area Governments, Woodward-Clyde, Central Coast Regional Water Quality Control Board. July 1998. (Revised February 2002 by the California Coastal Commission).

Orange County Stormwater Program

[http://www.ocwatersheds.com/StormWater/swp\\_introduction.asp](http://www.ocwatersheds.com/StormWater/swp_introduction.asp).

Santa Clara Valley Urban Runoff Pollution Prevention Program. 1997 Urban Runoff Management Plan. September 1997, updated October 2000.

# Water & Sewer Utility Maintenance SC-76



## Objectives

- Contain
- Educate
- Reduce/Minimize

## Description

Although the operation and maintenance of public utilities are not considered chronic sources of stormwater pollution, some activities and accidents can result in the discharge of pollutants that can pose a threat to both human health and the quality of receiving waters if they enter the storm drain system. Sewage incident response and investigation may involve a coordinated effort between staff from a number of different departments/agencies. Cities that do not provide maintenance of water and sewer utilities must coordinate with the contracting agency responsible for these activities and ensure that these model procedures are followed.

## Approach

### ***Pollution Prevention***

Inspect potential non-stormwater discharge flow paths and clear/cleanup any debris or pollutants found (i.e. remove trash, leaves, sediment, and wipe up liquids, including oil spills).

### ***Suggested Protocols***

#### *Water Line Maintenance and Cleaning*

Procedures can be employed to reduce pollutants from discharges associated with water utility operation and maintenance activities. Planned discharges may include fire hydrant testing, flushing water supply mains after new construction, flushing lines due to complaints of taste and odor, dewatering mains for maintenance work. Unplanned discharges from treated, recycled water, raw water, and groundwater systems operation and maintenance activities can occur from water main

## Targeted Constituents

Sediment	<input checked="" type="checkbox"/>
Nutrients	<input checked="" type="checkbox"/>
Trash	
Metals	
Bacteria	<input checked="" type="checkbox"/>
Oil and Grease	<input checked="" type="checkbox"/>
Organics	<input checked="" type="checkbox"/>
Oxygen Demanding	<input checked="" type="checkbox"/>



# **SC-76 Water & Sewer Utility Maintenance**

---

breaks, sheared fire hydrants, equipment malfunction, and operator error.

## *Planned discharges*

- Identify a suitable discharge option in the following order of preference:
  - Apply to the land.
  - Reuse water for dust suppression, irrigation, or construction compaction.
  - Discharge to a sanitary sewer system with approval.
  - Discharge to the storm drain system using applicable pollution control measures. (Only available to clean water discharges such as water main/ water storage tank/water hydrant flushing).
- If water is discharged to a storm drain, control measures must be put in place to control potential pollutants (i.e. sediment, chlorine, etc.). Examples of some storm drain protection options include:
  - Silt fence – appropriate where the inlet drains a relatively flat area.
  - Gravel and wire mesh sediment filter – Appropriate where concentrated flows are expected.
  - Wooden weir and fabric – use at curb inlets where a compact installation is desired.
- Prior to discharge, inspect discharge flow path and clear/cleanup any debris or pollutants found (i.e. remove trash, leaves, sediment, and wipe up liquids, including oil spills).
- General Design considerations for inlet protection devices include the following:
  - The device should be constructed such that cleaning and disposal of trapped sediment is made easy, while minimizing interference with discharge activities.
  - Devices should be constructed so that any standing water resulting from the discharge will not cause excessive inconvenience or flooding/damage to adjacent land or structures.
- The effectiveness of control devices must be monitored during the discharge period and any necessary repairs or modifications made.

## *Unplanned Discharges*

- Stop the discharge as quickly as possible.
- Inspect flow path of the discharged water:
  - Identify erodible areas which may need to be repaired or protected during subsequent repairs or corrective actions

# Water & Sewer Utility Maintenance SC-76

---

- Identify the potential for pollutants to be washed into the waterway
- If repairs or corrective action will cause additional discharges of water, select the appropriate procedures for erosion control, chlorine residual, turbidity, and chemical additives. Prevent potential pollutants from entering the flow path.

## *Sanitary Sewer Maintenance*

Applicable to municipalities who own and operated a sewage collection system. Facilities that are covered under this program include sanitary sewer pipes and pump stations owned and operated by a municipality. The owner of the sanitary sewer facilities is the entity responsible for carrying out this prevention and response program.

- Clean sewer lines on a regular basis to remove grease, grit, and other debris that may lead to sewer backups.
- Establish routine maintenance program. Cleaning should be conducted at an established minimum frequency and more frequently for problem areas such as restaurants that are identified
- Cleaning activities may require removal of tree roots and other identified obstructions.
- During routine maintenance and inspection note the condition of sanitary sewer structures and identify areas that need repair or maintenance. Items to note may include the following:
  - Cracked/deteriorating pipes
  - Leaking joints/seals at manhole
  - Frequent line plugs
  - Line generally flows at or near capacity
  - Suspected infiltration or exfiltration.
- Prioritize repairs based on the nature and severity of the problem. Immediate clearing of blockage or repair is required where an overflow is currently occurring or for urgent problems that may cause an imminent overflow (e.g. pump station failures, sewer line ruptures, sewer line blockages). These repairs may be temporary until scheduled or capital improvements can be completed.
- Review previous sewer maintenance records to help identify “hot spots” or areas with frequent maintenance problems and locations of potential system failure.

## *Spills and Overflows*

- Identify and track sanitary sewer discharges. Identify dry weather infiltration and inflow first. Wet weather overflow connections are very difficult to locate.

# **SC-76 Water & Sewer Utility Maintenance**

---

- Locate wet weather overflows and leaking sanitary sewers using conventional source identification techniques such as monitoring and field screening. Techniques used to identify other illicit connection sources can also be used for sewer system evaluation surveys (see SC74 Drainage System Operation and Maintenance).
- Implement community awareness programs for monitoring sanitary sewer wet weather overflows. A citizen's hotline for reporting observed overflow conditions should be established to supplement field screening efforts.
- Establish lead department/agency responsible for spill response and containment. Provide coordination within departments.
- When a spill, leak, and/or overflow occurs and when disinfecting a sewage contaminated area, take every effort to ensure that the sewage, disinfectant and/or sewage treated with the disinfectant is not discharged to the storm drain system or receiving waters. Methods may include:
  - Blocking storm drain inlets and catch basins
  - Containing and diverting sewage and disinfectant away from open channels and other storm drain fixtures (using sandbags, inflatable dams, etc.)
  - Removing the material with vacuum equipment
- Record required information at the spill site.
- Perform field tests as necessary to determine the source of the spill.
- Develop notification procedures regarding spill reporting.

## ***Septic Systems***

- Ensure that homeowners, installers, and inspectors are educated in proper maintenance of septic systems. This may require coordination with staff from other departments. Outreach to homeowners should include inspection reminders informing them that inspection and perhaps maintenance is due for their systems. Recommend that the system be inspected annually and pumped-out regularly.
- Programs which seek to address failing septic systems should consider using field screening to pinpoint areas where more detailed onsite inspection surveys are warranted.

## ***Training***

- Conduct annual training of water utility personnel and service contractors. (field screening, sampling, smoke/dye testing, TV inspection).
- OSHA-required Health and Safety Training 29 CFR 1910.120 plus annual Refresher Training (as needed).
- OSHA Confined Space Entry training (Cal-OSHA Confined Space, Title 8 and federal OSHA 29 CFR 1910.146).

# **Water & Sewer Utility Maintenance SC-76**

---

## ***Spill Response and Prevention***

- See previous section regarding spills and overflows.
- Refer to SC-11, Spill Prevention, Control & Cleanup.
- Have spill cleanup materials readily available and in a known location.
- Cleanup spills immediately and use dry methods if possible.
- Properly dispose of spill cleanup material.

## ***Other Considerations***

- Enact ordinance granting “right-of-entry” to locate potentially responsible parties for sewer overflows.
- Reliance on individual onsite inspection to detect failed septic systems can be a major limitation. The individual onsite inspection is very labor-intensive and requires access to private property to pinpoint the exact location of the failing system.
- A significant limitation to correcting failing septic systems is the lack of techniques available for detecting individual failed septic systems.

## **Requirements**

### ***Costs***

- Departmental cooperation recommended for sharing or borrowing staff resources and equipment from municipal wastewater department.
- Infiltration, inflow, and wet weather overflows from sanitary sewers are very labor and equipment intensive to locate.
- The costs associated with detecting and correcting septic system failures are subject to a number of factors, including availability of trained personnel, cost of materials, and the level of follow-up required to fix the system problems.

### ***Maintenance***

- Minimum 2-person teams to perform field screening and associated sampling.
- Larger teams required for implementing other techniques (i.e. zinc chloride smoke testing, fluorometric dye testing, television camera inspection and physical inspection with confined space entry) to identify sewer system leaks.
- Program coordination required for handling emergencies, record keeping, etc.
- Many of the problems associated with improper use of septic systems may be attributed to lack of user knowledge on operation and maintenance. Educational materials for homeowners and training courses for installers and inspectors can reduce the incidence of pollution from these widespread and commonly used pollution control devices.

# SC-76 Water & Sewer Utility Maintenance

---

## Supplemental Information

### *Further Detail of the BMP*

#### *Onsite Sewage Disposal Systems*

New onsite sewage disposal systems should be designed, located, and installed away from open waterbodies and sensitive resources such as wetlands and floodplains. A protective separation between the OSDS and groundwater should also be established. OSDSs should be operated and maintained to prevent surface water discharges and reduce pollutant loadings to groundwater. Inspection of OSDSs should occur regularly and repairs made immediately. New or replacement plumbing fixtures should be of the high efficiency type.

#### *Typical Sanitary Sewer Problems*

- Old and deteriorated main and lateral pipes - Sewers range in age from 30 to 100 years with an average age of 50 years.
- Cracked sewer pipes - Existing sewers are mostly clay pipes which can crack as they deteriorate with age and also by earth movement.
- Misaligned and open pipe joints - Most of the mortar used to seal the joints between sections of clay pipe has deteriorated.
- Undersized sewer pipe - The existing sewer system is overloaded due to new sewer hook-ups, underground water infiltration, and illegal roof and/or yard drain connections.
- Defective manholes - Old manholes are made of bricks. Typical problems associated with brick manholes are loose bricks, missing bricks, and misaligned manholes.
- Missing and/or unrecorded sewer pipes and manholes - This problem is typical in the easement/backline sewer. Sewer pipe locations shown on the sewer record map are different from the actual sewer location.
- Sewer main under houses and other improvements - Complaints of sewer main alignment crossing the house and other improvements. A solution to this problem requires an agreement with the property owner for a new sewer easement at a relocated line.

#### *Causes of Sanitary Sewer Backups*

- Root infiltration - Tree roots are a major cause of backups.
- Water inflow/infiltration - Rain water entering the sewer pipe causes overflows.
- Solids - Typical solids that buildup in the pipe and cause backups are grease, dirt, bones, tampons, paper towels, diapers, broken dishware, garbage, concrete, and debris.
- Structural defects in pipes and manholes - Sags in the line, cracks, holes, protruding laterals, misaligned pipe, offset joints are all possible causes of backups.

# **Water & Sewer Utility Maintenance SC-76**

---

## *Design Considerations*

Sanitary sewer overflows can often be reduced or eliminated by a number of practices, in addition to sewer system cleaning and maintenance, including the following:

- Reducing infiltration and inflow through rehabilitation and repair of broken or leaking sewer lines.
- Enlarging or upgrading the capacity of sewer lines, pump stations, or sewage treatment plants.
- Constructing wet weather storage and treatment facilities to treat excess flows.
- Addressing SSOs during sewer system master planning and facilities planning.

## *Septic Systems*

Two field screening techniques that have been used with success at identifying possible locations of failing septic systems are the brightener test and color infrared (CIR) aerial photography. The first involves the use of specific phosphorus-based elements found in many laundry products, often called brighteners, as an indicator of the presence of failing onsite wastewater systems. The second technique uses color infrared (CIR) aerial photography to characterize the performance of septic systems. This method has been found to be a quick and cost-effective method for assessing the potential impacts of failing systems and uses variations in vegetative growth or stress patterns over septic system field lines to identify those systems that may potentially be malfunctioning. Then a more detailed onsite visual and physical inspection will confirm whether the system has truly failed and the extent of the repairs needed. These inspections may be carried out by county health departments or other authorized personnel.

## **References and Resources**

Alameda Countywide Clean Water Program on-line

<http://www.ci.berkeley.ca.us/pw/Storm/stormala.html>

Los Angeles County Stormwater Quality. Public Agency Activities Model Program. On-line:

[http://ladpw.org/wmd/npdes/public\\_TC.cfm](http://ladpw.org/wmd/npdes/public_TC.cfm)

Orange County Stormwater Program

[http://www.ocwatersheds.com/StormWater/swp\\_introduction.asp](http://www.ocwatersheds.com/StormWater/swp_introduction.asp)

Santa Clara Valley Urban Runoff Pollution Prevention Program. 1997 Urban Runoff Management Plan. September 1997, updated October 2000.

Santa Clara Valley Urban Runoff Pollution Prevention Program. 1998. Water Utility Operation and Maintenance Discharge Pollution Prevention Plan. June

United States Environmental Protection Agency (USEPA). 2001. Illicit Discharge Detection and Elimination. On-line: [http://cfpub.epa.gov/npdes/stormwater/menuofbmps/illi\\_1.cfm](http://cfpub.epa.gov/npdes/stormwater/menuofbmps/illi_1.cfm)

# **SC-76 Water & Sewer Utility Maintenance**

United States Environmental Protection Agency (USEPA). 2001. Pollution Prevention/Good Housekeeping for Municipal Operators Septic System Controls. On-line:  
[http://www.epa.gov/npdes/menuofbmps/poll\\_14.htm](http://www.epa.gov/npdes/menuofbmps/poll_14.htm)

# Site Design & Landscape Planning SD-10



---

## Design Objectives

---

- ✓ Maximize Infiltration
  - ✓ Provide Retention
  - ✓ Slow Runoff
  - ✓ Minimize Impervious Land Coverage
  - Prohibit Dumping of Improper Materials
  - Contain Pollutants
  - Collect and Convey
- 

## Description

Each project site possesses unique topographic, hydrologic, and vegetative features, some of which are more suitable for development than others. Integrating and incorporating appropriate landscape planning methodologies into the project design is the most effective action that can be done to minimize surface and groundwater contamination from stormwater.

## Approach

Landscape planning should couple consideration of land suitability for urban uses with consideration of community goals and projected growth. Project plan designs should conserve natural areas to the extent possible, maximize natural water storage and infiltration opportunities, and protect slopes and channels.

## Suitable Applications

Appropriate applications include residential, commercial and industrial areas planned for development or redevelopment.

## Design Considerations

Design requirements for site design and landscapes planning should conform to applicable standards and specifications of agencies with jurisdiction and be consistent with applicable General Plan and Local Area Plan policies.



# **SD-10 Site Design & Landscape Planning**

## ***Designing New Installations***

Begin the development of a plan for the landscape unit with attention to the following general principles:

- Formulate the plan on the basis of clearly articulated community goals. Carefully identify conflicts and choices between retaining and protecting desired resources and community growth.
- Map and assess land suitability for urban uses. Include the following landscape features in the assessment: wooded land, open unwooded land, steep slopes, erosion-prone soils, foundation suitability, soil suitability for waste disposal, aquifers, aquifer recharge areas, wetlands, floodplains, surface waters, agricultural lands, and various categories of urban land use. When appropriate, the assessment can highlight outstanding local or regional resources that the community determines should be protected (e.g., a scenic area, recreational area, threatened species habitat, farmland, fish run). Mapping and assessment should recognize not only these resources but also additional areas needed for their sustenance.

Project plan designs should conserve natural areas to the extent possible, maximize natural water storage and infiltration opportunities, and protect slopes and channels.

## ***Conserve Natural Areas during Landscape Planning***

If applicable, the following items are required and must be implemented in the site layout during the subdivision design and approval process, consistent with applicable General Plan and Local Area Plan policies:

- Cluster development on least-sensitive portions of a site while leaving the remaining land in a natural undisturbed condition.
- Limit clearing and grading of native vegetation at a site to the minimum amount needed to build lots, allow access, and provide fire protection.
- Maximize trees and other vegetation at each site by planting additional vegetation, clustering tree areas, and promoting the use of native and/or drought tolerant plants.
- Promote natural vegetation by using parking lot islands and other landscaped areas.
- Preserve riparian areas and wetlands.

## ***Maximize Natural Water Storage and Infiltration Opportunities Within the Landscape Unit***

- Promote the conservation of forest cover. Building on land that is already deforested affects basin hydrology to a lesser extent than converting forested land. Loss of forest cover reduces interception storage, detention in the organic forest floor layer, and water losses by evapotranspiration, resulting in large peak runoff increases and either their negative effects or the expense of countering them with structural solutions.
- Maintain natural storage reservoirs and drainage corridors, including depressions, areas of permeable soils, swales, and intermittent streams. Develop and implement policies and

# **Site Design & Landscape Planning SD-10**

---

regulations to discourage the clearing, filling, and channelization of these features. Utilize them in drainage networks in preference to pipes, culverts, and engineered ditches.

- Evaluating infiltration opportunities by referring to the stormwater management manual for the jurisdiction and pay particular attention to the selection criteria for avoiding groundwater contamination, poor soils, and hydrogeological conditions that cause these facilities to fail. If necessary, locate developments with large amounts of impervious surfaces or a potential to produce relatively contaminated runoff away from groundwater recharge areas.

## *Protection of Slopes and Channels during Landscape Design*

- Convey runoff safely from the tops of slopes.
- Avoid disturbing steep or unstable slopes.
- Avoid disturbing natural channels.
- Stabilize disturbed slopes as quickly as possible.
- Vegetate slopes with native or drought tolerant vegetation.
- Control and treat flows in landscaping and/or other controls prior to reaching existing natural drainage systems.
- Stabilize temporary and permanent channel crossings as quickly as possible, and ensure that increases in run-off velocity and frequency caused by the project do not erode the channel.
- Install energy dissipaters, such as riprap, at the outlets of new storm drains, culverts, conduits, or channels that enter unlined channels in accordance with applicable specifications to minimize erosion. Energy dissipaters shall be installed in such a way as to minimize impacts to receiving waters.
- Line on-site conveyance channels where appropriate, to reduce erosion caused by increased flow velocity due to increases in tributary impervious area. The first choice for linings should be grass or some other vegetative surface, since these materials not only reduce runoff velocities, but also provide water quality benefits from filtration and infiltration. If velocities in the channel are high enough to erode grass or other vegetative linings, riprap, concrete, soil cement, or geo-grid stabilization are other alternatives.
- Consider other design principles that are comparable and equally effective.

## ***Redeveloping Existing Installations***

Various jurisdictional stormwater management and mitigation plans (SUSMP, WQMP, etc.) define “redevelopment” in terms of amounts of additional impervious area, increases in gross floor area and/or exterior construction, and land disturbing activities with structural or impervious surfaces. The definition of “redevelopment” must be consulted to determine whether or not the requirements for new development apply to areas intended for redevelopment. If the definition applies, the steps outlined under “designing new installations” above should be followed.

## **SD-10 Site Design & Landscape Planning**

Redevelopment may present significant opportunity to add features which had not previously been implemented. Examples include incorporation of depressions, areas of permeable soils, and swales in newly redeveloped areas. While some site constraints may exist due to the status of already existing infrastructure, opportunities should not be missed to maximize infiltration, slow runoff, reduce impervious areas, disconnect directly connected impervious areas.

### **Other Resources**

A Manual for the Standard Urban Stormwater Mitigation Plan (SUSMP), Los Angeles County Department of Public Works, May 2002.

Stormwater Management Manual for Western Washington, Washington State Department of Ecology, August 2001.

Model Standard Urban Storm Water Mitigation Plan (SUSMP) for San Diego County, Port of San Diego, and Cities in San Diego County, February 14, 2002.

Model Water Quality Management Plan (WQMP) for County of Orange, Orange County Flood Control District, and the Incorporated Cities of Orange County, Draft February 2003.

Ventura Countywide Technical Guidance Manual for Stormwater Quality Control Measures, July 2002.



Rain Garden

---

## Design Objectives

---

- ✓ Maximize Infiltration
  - ✓ Provide Retention
  - ✓ Slow Runoff
  - Minimize Impervious Land Coverage
  - Prohibit Dumping of Improper Materials
  - ✓ Contain Pollutants
  - Collect and Convey
- 

## Description

Various roof runoff controls are available to address stormwater that drains off rooftops. The objective is to reduce the total volume and rate of runoff from individual lots, and retain the pollutants on site that may be picked up from roofing materials and atmospheric deposition. Roof runoff controls consist of directing the roof runoff away from paved areas and mitigating flow to the storm drain system through one of several general approaches: cisterns or rain barrels; dry wells or infiltration trenches; pop-up emitters, and foundation planting. The first three approaches require the roof runoff to be contained in a gutter and downspout system. Foundation planting provides a vegetated strip under the drip line of the roof.

## Approach

Design of individual lots for single-family homes as well as lots for higher density residential and commercial structures should consider site design provisions for containing and infiltrating roof runoff or directing roof runoff to vegetative swales or buffer areas. Retained water can be reused for watering gardens, lawns, and trees. Benefits to the environment include reduced demand for potable water used for irrigation, improved stormwater quality, increased groundwater recharge, decreased runoff volume and peak flows, and decreased flooding potential.

## Suitable Applications

Appropriate applications include residential, commercial and industrial areas planned for development or redevelopment.

## Design Considerations

### *Designing New Installations*

#### *Cisterns or Rain Barrels*

One method of addressing roof runoff is to direct roof downspouts to cisterns or rain barrels. A cistern is an above ground storage vessel with either a manually operated valve or a permanently open outlet. Roof runoff is temporarily stored and then released for irrigation or infiltration between storms. The number of rain



barrels needed is a function of the rooftop area. Some low impact developers recommend that every house have at least 2 rain barrels, with a minimum storage capacity of 1000 liters. Roof barrels serve several purposes including mitigating the first flush from the roof which has a high volume, amount of contaminants, and thermal load. Several types of rain barrels are commercially available. Consideration must be given to selecting rain barrels that are vector proof and childproof. In addition, some barrels are designed with a bypass valve that filters out grit and other contaminants and routes overflow to a soak-away pit or rain garden.

If the cistern has an operable valve, the valve can be closed to store stormwater for irrigation or infiltration between storms. This system requires continual monitoring by the resident or grounds crews, but provides greater flexibility in water storage and metering. If a cistern is provided with an operable valve and water is stored inside for long periods, the cistern must be covered to prevent mosquitoes from breeding.

A cistern system with a permanently open outlet can also provide for metering stormwater runoff. If the cistern outlet is significantly smaller than the size of the downspout inlet (say  $\frac{1}{4}$  to  $\frac{1}{2}$  inch diameter), runoff will build up inside the cistern during storms, and will empty out slowly after peak intensities subside. This is a feasible way to mitigate the peak flow increases caused by rooftop impervious land coverage, especially for the frequent, small storms.

#### *Dry wells and Infiltration Trenches*

Roof downspouts can be directed to dry wells or infiltration trenches. A dry well is constructed by excavating a hole in the ground and filling it with an open graded aggregate, and allowing the water to fill the dry well and infiltrate after the storm event. An underground connection from the downspout conveys water into the dry well, allowing it to be stored in the voids. To minimize sedimentation from lateral soil movement, the sides and top of the stone storage matrix can be wrapped in a permeable filter fabric, though the bottom may remain open. A perforated observation pipe can be inserted vertically into the dry well to allow for inspection and maintenance.

In practice, dry wells receiving runoff from single roof downspouts have been successful over long periods because they contain very little sediment. They must be sized according to the amount of rooftop runoff received, but are typically 4 to 5 feet square, and 2 to 3 feet deep, with a minimum of 1-foot soil cover over the top (maximum depth of 10 feet).

To protect the foundation, dry wells must be set away from the building at least 10 feet. They must be installed in solids that accommodate infiltration. In poorly drained soils, dry wells have very limited feasibility.

Infiltration trenches function in a similar manner and would be particularly effective for larger roof areas. An infiltration trench is a long, narrow, rock-filled trench with no outlet that receives stormwater runoff. These are described under Treatment Controls.

#### *Pop-up Drainage Emitter*

Roof downspouts can be directed to an underground pipe that daylight some distance from the building foundation, releasing the roof runoff through a pop-up emitter. Similar to a pop-up irrigation head, the emitter only opens when there is flow from the roof. The emitter remains flush to the ground during dry periods, for ease of lawn or landscape maintenance.

## *Foundation Planting*

Landscape planting can be provided around the base to allow increased opportunities for stormwater infiltration and protect the soil from erosion caused by concentrated sheet flow coming off the roof. Foundation plantings can reduce the physical impact of water on the soil and provide a subsurface matrix of roots that encourage infiltration. These plantings must be sturdy enough to tolerate the heavy runoff sheet flows, and periodic soil saturation.

## ***Redeveloping Existing Installations***

Various jurisdictional stormwater management and mitigation plans (SUSMP, WQMP, etc.) define “redevelopment” in terms of amounts of additional impervious area, increases in gross floor area and/or exterior construction, and land disturbing activities with structural or impervious surfaces. The definition of “redevelopment” must be consulted to determine whether or not the requirements for new development apply to areas intended for redevelopment. If the definition applies, the steps outlined under “designing new installations” above should be followed.

## **Supplemental Information**

### ***Examples***

- City of Ottawa’s Water Links Surface –Water Quality Protection Program
- City of Toronto Downspout Disconnection Program
- City of Boston, MA, Rain Barrel Demonstration Program

### **Other Resources**

Hager, Marty Catherine, Stormwater, “Low-Impact Development”, January/February 2003.  
[www.stormh2o.com](http://www.stormh2o.com)

Low Impact Urban Design Tools, Low Impact Development Design Center, Beltsville, MD.  
[www.lid-stormwater.net](http://www.lid-stormwater.net)

Start at the Source, Bay Area Stormwater Management Agencies Association, 1999 Edition

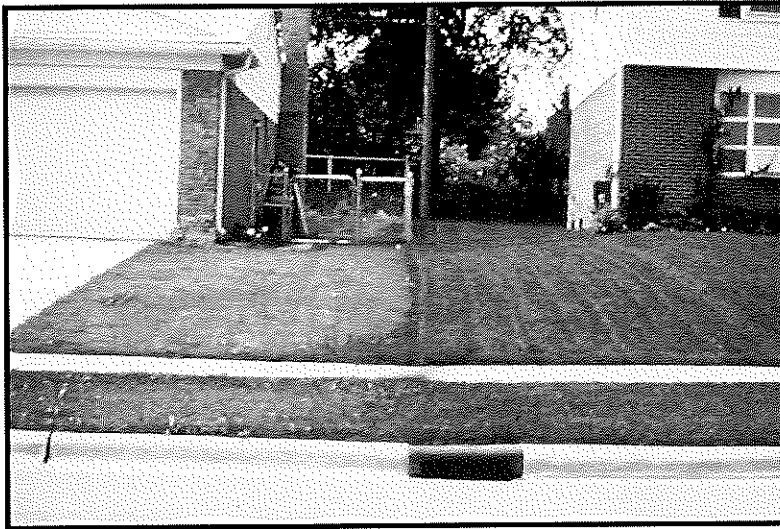

## Design Objectives

- ✓ Maximize Infiltration
- ✓ Provide Retention
- ✓ Slow Runoff
- Minimize Impervious Land Coverage
- Prohibit Dumping of Improper Materials
- Contain Pollutants
- Collect and Convey

## Description

Irrigation water provided to landscaped areas may result in excess irrigation water being conveyed into stormwater drainage systems.

## Approach

Project plan designs for development and redevelopment should include application methods of irrigation water that minimize runoff of excess irrigation water into the stormwater conveyance system.

## Suitable Applications

Appropriate applications include residential, commercial and industrial areas planned for development or redevelopment. (Detached residential single-family homes are typically excluded from this requirement.)

## Design Considerations

### *Designing New Installations*

The following methods to reduce excessive irrigation runoff should be considered, and incorporated and implemented where determined applicable and feasible by the Permittee:

- Employ rain-triggered shutoff devices to prevent irrigation after precipitation.
- Design irrigation systems to each landscape area's specific water requirements.
- Include design featuring flow reducers or shutoff valves triggered by a pressure drop to control water loss in the event of broken sprinkler heads or lines.
- Implement landscape plans consistent with County or City water conservation resolutions, which may include provision of water sensors, programmable irrigation times (for short cycles), etc.



- Design timing and application methods of irrigation water to minimize the runoff of excess irrigation water into the storm water drainage system.
- Group plants with similar water requirements in order to reduce excess irrigation runoff and promote surface filtration. Choose plants with low irrigation requirements (for example, native or drought tolerant species). Consider design features such as:
  - Using mulches (such as wood chips or bar) in planter areas without ground cover to minimize sediment in runoff
  - Installing appropriate plant materials for the location, in accordance with amount of sunlight and climate, and use native plant materials where possible and/or as recommended by the landscape architect
  - Leaving a vegetative barrier along the property boundary and interior watercourses, to act as a pollutant filter, where appropriate and feasible
  - Choosing plants that minimize or eliminate the use of fertilizer or pesticides to sustain growth
- Employ other comparable, equally effective methods to reduce irrigation water runoff.

***Redeveloping Existing Installations***

Various jurisdictional stormwater management and mitigation plans (SUSMP, WQMP, etc.) define “redevelopment” in terms of amounts of additional impervious area, increases in gross floor area and/or exterior construction, and land disturbing activities with structural or impervious surfaces. The definition of “redevelopment” must be consulted to determine whether or not the requirements for new development apply to areas intended for redevelopment. If the definition applies, the steps outlined under “designing new installations” above should be followed.

**Other Resources**

A Manual for the Standard Urban Stormwater Mitigation Plan (SUSMP), Los Angeles County Department of Public Works, May 2002.

Model Standard Urban Storm Water Mitigation Plan (SUSMP) for San Diego County, Port of San Diego, and Cities in San Diego County, February 14, 2002.

Model Water Quality Management Plan (WQMP) for County of Orange, Orange County Flood Control District, and the Incorporated Cities of Orange County, Draft February 2003.

Ventura Countywide Technical Guidance Manual for Stormwater Quality Control Measures, July 2002.



## Design Objectives

- Maximize Infiltration
- Provide Retention
- Slow Runoff
- Minimize Impervious Land Coverage
- ✓ Prohibit Dumping of Improper Materials
- Contain Pollutants
- Collect and Convey

## Description

Waste materials dumped into storm drain inlets can have severe impacts on receiving and ground waters. Posting notices regarding discharge prohibitions at storm drain inlets can prevent waste dumping. Storm drain signs and stencils are highly visible source controls that are typically placed directly adjacent to storm drain inlets.

## Approach

The stencil or affixed sign contains a brief statement that prohibits dumping of improper materials into the urban runoff conveyance system. Storm drain messages have become a popular method of alerting the public about the effects of and the prohibitions against waste disposal.

## Suitable Applications

Stencils and signs alert the public to the destination of pollutants discharged to the storm drain. Signs are appropriate in residential, commercial, and industrial areas, as well as any other area where contributions or dumping to storm drains is likely.

## Design Considerations

Storm drain message markers or placards are recommended at all storm drain inlets within the boundary of a development project. The marker should be placed in clear sight facing toward anyone approaching the inlet from either side. All storm drain inlet locations should be identified on the development site map.

## Designing New Installations

The following methods should be considered for inclusion in the project design and show on project plans:

- Provide stenciling or labeling of all storm drain inlets and catch basins, constructed or modified, within the project area with prohibitive language. Examples include “NO DUMPING –



DRAINS TO OCEAN” and/or other graphical icons to discourage illegal dumping.

- Post signs with prohibitive language and/or graphical icons, which prohibit illegal dumping at public access points along channels and creeks within the project area.

Note - Some local agencies have approved specific signage and/or storm drain message placards for use. Consult local agency stormwater staff to determine specific requirements for placard types and methods of application.

### ***Redeveloping Existing Installations***

Various jurisdictional stormwater management and mitigation plans (SUSMP, WQMP, etc.) define “redevelopment” in terms of amounts of additional impervious area, increases in gross floor area and/or exterior construction, and land disturbing activities with structural or impervious surfaces. If the project meets the definition of “redevelopment”, then the requirements stated under “designing new installations” above should be included in all project design plans.

### **Additional Information**

#### ***Maintenance Considerations***

- Legibility of markers and signs should be maintained. If required by the agency with jurisdiction over the project, the owner/operator or homeowner’s association should enter into a maintenance agreement with the agency or record a deed restriction upon the property title to maintain the legibility of placards or signs.

#### ***Placement***

- Signage on top of curbs tends to weather and fade.
- Signage on face of curbs tends to be worn by contact with vehicle tires and sweeper brooms.

### **Supplemental Information**

#### ***Examples***

- Most MS4 programs have storm drain signage programs. Some MS4 programs will provide stencils, or arrange for volunteers to stencil storm drains as part of their outreach program.

### **Other Resources**

A Manual for the Standard Urban Stormwater Mitigation Plan (SUSMP), Los Angeles County Department of Public Works, May 2002.

Model Standard Urban Storm Water Mitigation Plan (SUSMP) for San Diego County, Port of San Diego, and Cities in San Diego County, February 14, 2002.

Model Water Quality Management Plan (WQMP) for County of Orange, Orange County Flood Control District, and the Incorporated Cities of Orange County, Draft February 2003.

Ventura Countywide Technical Guidance Manual for Stormwater Quality Control Measures, July 2002.

## Description

Trash storage areas are areas where a trash receptacle (s) are located for use as a repository for solid wastes. Stormwater runoff from areas where trash is stored or disposed of can be polluted. In addition, loose trash and debris can be easily transported by water or wind into nearby storm drain inlets, channels, and/or creeks. Waste handling operations that may be sources of stormwater pollution include dumpsters, litter control, and waste piles.

## Approach

This fact sheet contains details on the specific measures required to prevent or reduce pollutants in stormwater runoff associated with trash storage and handling. Preventative measures including enclosures, containment structures, and impervious pavements to mitigate spills, should be used to reduce the likelihood of contamination.

## Suitable Applications

Appropriate applications include residential, commercial and industrial areas planned for development or redevelopment. (Detached residential single-family homes are typically excluded from this requirement.)

## Design Considerations

Design requirements for waste handling areas are governed by Building and Fire Codes, and by current local agency ordinances and zoning requirements. The design criteria described in this fact sheet are meant to enhance and be consistent with these code and ordinance requirements. Hazardous waste should be handled in accordance with legal requirements established in Title 22, California Code of Regulation.

Wastes from commercial and industrial sites are typically hauled by either public or commercial carriers that may have design or access requirements for waste storage areas. The design criteria in this fact sheet are recommendations and are not intended to be in conflict with requirements established by the waste hauler. The waste hauler should be contacted prior to the design of your site trash collection areas. Conflicts or issues should be discussed with the local agency.

## Designing New Installations

Trash storage areas should be designed to consider the following structural or treatment control BMPs:

- Design trash container areas so that drainage from adjoining roofs and pavement is diverted around the area(s) to avoid run-on. This might include berming or grading the waste handling area to prevent run-on of stormwater.
- Make sure trash container areas are screened or walled to prevent off-site transport of trash.

## Design Objectives

- Maximize Infiltration
- Provide Retention
- Slow Runoff
- Minimize Impervious Land Coverage
- Prohibit Dumping of Improper Materials
- ✓ Contain Pollutants
- Collect and Convey



- Use lined bins or dumpsters to reduce leaking of liquid waste.
- Provide roofs, awnings, or attached lids on all trash containers to minimize direct precipitation and prevent rainfall from entering containers.
- Pave trash storage areas with an impervious surface to mitigate spills.
- Do not locate storm drains in immediate vicinity of the trash storage area.
- Post signs on all dumpsters informing users that hazardous materials are not to be disposed of therein.

***Redeveloping Existing Installations***

Various jurisdictional stormwater management and mitigation plans (SUSMP, WQMP, etc.) define “redevelopment” in terms of amounts of additional impervious area, increases in gross floor area and/or exterior construction, and land disturbing activities with structural or impervious surfaces. The definition of “redevelopment” must be consulted to determine whether or not the requirements for new development apply to areas intended for redevelopment. If the definition applies, the steps outlined under “designing new installations” above should be followed.

**Additional Information*****Maintenance Considerations***

The integrity of structural elements that are subject to damage (i.e., screens, covers, and signs) must be maintained by the owner/operator. Maintenance agreements between the local agency and the owner/operator may be required. Some agencies will require maintenance deed restrictions to be recorded of the property title. If required by the local agency, maintenance agreements or deed restrictions must be executed by the owner/operator before improvement plans are approved.

**Other Resources**

A Manual for the Standard Urban Stormwater Mitigation Plan (SUSMP), Los Angeles County Department of Public Works, May 2002.

Model Standard Urban Storm Water Mitigation Plan (SUSMP) for San Diego County, Port of San Diego, and Cities in San Diego County, February 14, 2002.

Model Water Quality Management Plan (WQMP) for County of Orange, Orange County Flood Control District, and the Incorporated Cities of Orange County, Draft February 2003.

Ventura Countywide Technical Guidance Manual for Stormwater Quality Control Measures, July 2002.

## IC2. ANIMAL HANDLING AREAS

### Best Management Practices (BMPs)

A BMP is a technique, measure or structural control that is used for a given set of conditions to improve the quality of the stormwater runoff in a cost effective manner<sup>1</sup>. The minimum required BMPs for this activity are outlined in the box to the right. Implementation of pollution prevention/good housekeeping measures may reduce or eliminate the need to implement other more costly or complicated procedures. Proper employee training is key to the success of BMP implementation.

The BMPs outlined in this fact sheet target the following pollutants:

Targeted Constituents	
Sediment	x
Nutrients	x
Floatable Materials	x
Metals	
Bacteria	x
Oil & Grease	
Organics & Toxicants	
Pesticides	
Oxygen Demanding	x

MINIMUM BEST MANAGEMENT PRACTICES	
<u>Pollution Prevention/Good Housekeeping</u>	
<ul style="list-style-type: none"> <li>• Use dry cleaning methods to clean animal handling areas regularly.</li> <li>• Properly collect and dispose of water when water is used for cleaning.</li> <li>• Prevent animals from moving away from controlled areas where BMPs are in use (e.g. fencing, leashing, etc.)</li> <li>• Clean storm drain inlet(s) on a regular schedule and after large storms.</li> </ul>	
<u>Stencil storm drains</u>	
<u>Training</u>	
<ul style="list-style-type: none"> <li>• Train employees on these BMPs, storm water discharge prohibitions, and wastewater discharge requirements.</li> <li>• Provide on-going employee training in pollution prevention.</li> </ul>	

Provided below are specific procedures associated with each of the minimum BMPs along with procedures for additional BMPs that should be considered if this activity takes place at a facility located near a sensitive waterbody. In order to meet the requirements for medium and high priority facilities, the owners/operators must select, install and maintain appropriate BMPs on site. Since the selection of the appropriate BMPs is a site-specific process, the types and numbers of additional BMPs will vary for each facility.

1. **Use dry cleaning methods to clean animal handling areas regularly.**
  - Sweeping animal handling areas is encouraged over other methods.
  - Properly dispose of droppings, uneaten food, and other potential contaminants.
2. **If water is used for cleaning:**
  - Do not discharge wash water to storm drains or other receiving waters.
  - Wash water should be collected and pumped to the sanitary sewer, do not allow wash water to enter storm drains. Refer to fact sheet *IC24 Wastewater Disposal* for guidance on appropriate methods for disposal of wash water to the sanitary sewer.
3. **Keep animals in paved and covered areas, if feasible.**
4. **If keeping animals in covered areas is not feasible, cover the ground with vegetation or some other type of ground cover such as mulch.**
5. **Prevent animals from moving away from controlled areas where BMPs are in use (e.g. fencing, leashing, etc.).**

<sup>1</sup> EPA " Preliminary Data Summary of Urban Stormwater Best Management Practices"

## Training

1. Train employees on these BMPs, storm water discharge prohibitions, and wastewater discharge requirements.
2. Train employees on proper spill containment and cleanup.
  - Establish training that provides employees with the proper tools and knowledge to immediately begin cleaning up a spill.
  - Ensure that employees are familiar with the site's spill control plan and/or proper spill cleanup procedures.
  - Fact sheet IC17 discusses Spill Prevention and Control in detail.
3. Establish a regular training schedule, train all new employees, and conduct annual refresher training.
4. Use a training log or similar method to document training.

### Stencil storm drains

Storm drain system signs act as highly visible source controls that are typically stenciled directly adjacent to storm drain inlets. Stencils should read "No Dumping Drains to Ocean".

## References

California Storm Water Best Management Practice Handbook. Industrial and Commercial. 2003.  
[www.cabmphandbooks.com](http://www.cabmphandbooks.com)

King County Stormwater Pollution Control Manual. Best Management Practices for Businesses. King County Surface Water Management. July 1995. On-line: <http://dnr.metrokc.gov/wlr/dss/spcm.htm>

Stormwater Management Manual for Western Washington. Volume IV Source Control BMPs. Prepared by Washington State Department of Ecology Water Quality Program. Publication No. 99-14. August 2001.

For additional information contact:

County of Orange/ OC Watersheds

Main: (714) 955-0600

24 hr Water Pollution Hotline: 1-877-89-SPILL

or visit our website at [www.ocwatersheds.com](http://www.ocwatersheds.com)

### IC3. BUILDING MAINTENANCE

#### Best Management Practices (BMPs)

A BMP is a technique, measure or structural control that is used for a given set of conditions to improve the quality of the stormwater runoff in a cost effective manner<sup>1</sup>. The minimum required BMPs for this activity are outlined in the box to the right. Implementation of pollution prevention/good housekeeping measures may reduce or eliminate the need to implement other more costly or complicated procedures. Proper employee training is key to the success of BMP implementation.

The BMPs outlined in this fact sheet target the following pollutants:

Targeted Constituents	
Sediment	X
Nutrients	X
Floatable Materials	
Metals	X
Bacteria	X
Oil & Grease	
Organics & Toxicants	
Pesticides	
Oxygen Demanding	

**MINIMUM BEST MANAGEMENT PRACTICES**

Pollution Prevention/Good Housekeeping

- Properly collect and dispose of water when pressure washing buildings, rooftops, and other large objects.
- Properly prepare work area before conducting building maintenance.
- Properly clean and dispose of equipment and wastes used and generated during building maintenance.
- Store toxic material under cover when not in use and during precipitation events.

Stencil storm drains

Training

- Train employees on these BMPs, storm water discharge prohibitions, and wastewater discharge requirements.
- Provide on-going employee training in pollution prevention.

Provided below are specific procedures associated with each of the minimum BMPs along with procedures for additional BMPs that should be considered if this activity takes place at a facility located near a sensitive waterbody. In order to meet the requirements for medium and high priority facilities, the owners/operators must select, install and maintain appropriate BMPs on site. Since the selection of the appropriate BMPs is a site-specific process, the types and numbers of additional BMPs will vary for each facility.

1. **Properly collect and dispose of water when pressure washing buildings, rooftops, and other large objects.**
  - If pressure washing where the surrounding area is paved, use a water collection device that enables collection of wash water and associated solids. Use a sump pump, wet vacuum or similarly effective device to collect the runoff and loose materials. Dispose of the collected runoff and solids properly. Refer to fact sheet *IC24 Wastewater Disposal* for guidance on appropriate methods for disposal of wash water to the sanitary sewer.
  - If pressure washing on a landscaped area (with or without soap), runoff must be dispersed as sheet flow as much as possible, rather than as a concentrated stream. The wash runoff must remain on the landscaping and not drain to pavement.
2. **Properly prepare work area before conducting building maintenance.**
  - Use ground or drop cloths underneath outdoor painting, scraping, and sandblasting work, and properly dispose of collected material daily.
  - Use a ground cloth or oversized tub for activities such as paint mixing and tool cleaning.

<sup>1</sup> EPA " Preliminary Data Summary of Urban Stormwater Best Management Practices"

3. **Properly clean and dispose of equipment and wastes used and generated during building maintenance.**
  - Clean paint brushes and tools covered with water-based paints in sinks connected to sanitary sewers or in portable containers that can be dumped into a sanitary sewer drain. Brushes and tools covered with non-water-based paints, finishes, or other materials must be cleaned in a manner that enables collection of used solvents (e.g., paint thinner, turpentine, etc.) for recycling or proper disposal.
  - Properly dispose of wash water, sweepings, and sediments.
  - Properly store equipment, chemicals, and wastes.
  - Do not dump any toxic substance or liquid waste on the pavement, the ground, or toward a storm drain.

OPTIONAL:

  - Recycle residual paints, solvents, lumber, and other materials to the maximum extent practicable
4. **Employ soil erosion and stabilization techniques when exposing large areas of soil.**
  - Confine excavated materials to pervious surfaces away from storm drain inlets, sidewalks, pavement, and ditches. Material must be covered if rain is expected.
  - Use chemical stabilization or geosynthetics to stabilize bare ground surfaces.
5. **Store toxic material under cover when not in use and during precipitation events.**
6. **Properly dispose of fluids from air conditioning, cooling tower, and condensate drains.**
7. **Regularly inspect air emission control equipment under AQMD permit.**
8. **Switch to non-toxic chemicals for maintenance when possible.**
  - If cleaning agents are used, select biodegradable products whenever feasible
  - Consider using a waterless and non-toxic chemical cleaning method for graffiti removal (e.g. gels or spray compounds).
9. **Use chemicals that can be recycled.**
  - Buy recycled products to the maximum extent practicable

#### Training

1. **Train employees on these BMPs, storm water discharge prohibitions, and wastewater discharge requirements.**
2. **Train employees on proper spill containment and cleanup.**
  - Establish training that provides employees with the proper tools and knowledge to immediately begin cleaning up a spill.
  - Ensure that employees are familiar with the site's spill control plan and/or proper spill cleanup procedures.
  - Fact sheet IC17 discusses Spill Prevention and Control in detail.
3. **Establish a regular training schedule, train all new employees, and conduct annual refresher training.**
4. **Use a training log or similar method to document training.**

#### Stencil storm drains

Storm drain system signs act as highly visible source controls that are typically stenciled directly adjacent to storm drain inlets. Stencils should read "No Dumping Drains to Ocean".

## References

California Storm Water Best Management Practice Handbook. Industrial and Commercial. 2003.  
[www.cabmphandbooks.com](http://www.cabmphandbooks.com)

California Storm Water Best Management Practice Handbooks. Industrial/Commercial Best Management Practice Handbook. Prepared by Camp Dresser & McKee, Larry Walker Associates, Uribe and Associates, Resources Planning Associates for Stormwater Quality Task Force. March 1993.

King County Stormwater Pollution Control Manual. Best Management Practices for Businesses. King County Surface Water Management. July 1995. On-line: <http://dnr.metrokc.gov/wlr/dss/spcm.htm>

Stormwater Management Manual for Western Washington. Volume IV Source Control BMPs. Prepared by Washington State Department of Ecology Water Quality Program. Publication No. 99-14. August 2001.

### For additional information contact:

#### County of Orange/ OC Watersheds

Main: (714) 955-0600

24 hr Water Pollution Hotline: 1-877-89-SPILL

or visit our website at [www.ocwatersheds.com](http://www.ocwatersheds.com)

## IC7. LANDSCAPE MAINTENANCE

### Best Management Practices (BMPs)

A BMP is a technique, measure or structural control that is used for a given set of conditions to improve the quality of the stormwater runoff in a cost effective manner<sup>1</sup>. The minimum required BMPs for this activity are outlined in the box to the right. Implementation of pollution prevention/good housekeeping measures may reduce or eliminate the need to implement other more costly or complicated procedures. Proper employee training is key to the success of BMP implementation.

The BMPs outlined in this fact sheet target the following pollutants:

Targeted Constituents	
Sediment	x
Nutrients	x
Floatable Materials	x
Metals	
Bacteria	x
Oil & Grease	
Organics & Toxicants	
Pesticides	x
Oxygen Demanding	x

#### MINIMUM BEST MANAGEMENT PRACTICES

##### Pollution Prevention/Good Housekeeping

- Properly store and dispose of gardening wastes.
- Use mulch or other erosion control measures on exposed soils.
- Properly manage irrigation and runoff.
- Properly store and dispose of chemicals.
- Properly manage pesticide and herbicide use.
- Properly manage fertilizer use.

##### Stencil storm drains

##### Training

- Train employees on these BMPs, storm water discharge prohibitions, and wastewater discharge requirements.
- Provide on-going employee training in pollution prevention.

Provided below are specific procedures associated with each of the minimum BMPs along with procedures for additional BMPs that should be considered if this activity takes place at a facility located near a sensitive waterbody. In order to meet the requirements for medium and high priority facilities, the owners/operators must select, install and maintain appropriate BMPs on site. Since the selection of the appropriate BMPs is a site-specific process, the types and numbers of additional BMPs will vary for each facility.

#### 1. Take steps to reduce landscape maintenance requirements.

- Where feasible, retain and/or plant native vegetation with features that are determined to be beneficial. Native vegetation usually requires less maintenance than planting new vegetation.
- When planting or replanting consider using low water use flowers, trees, shrubs, and groundcovers.
- Consider alternative landscaping techniques such as naturoscaping and xeriscaping.

#### 2. Properly store and dispose of gardening wastes.

- Dispose of grass clippings, leaves, sticks, or other collected vegetation as garbage at a permitted landfill or by composting.
- Do not dispose of gardening wastes in streets, waterways, or storm drainage systems.
- Place temporarily stockpiled material away from watercourses and storm drain inlets, and berm and/or cover.

#### 3. Use mulch or other erosion control measures on exposed soils.

<sup>1</sup> EPA " Preliminary Data Summary of Urban Stormwater Best Management Practices"

4. **Properly manage irrigation and runoff.**
  - Irrigate slowly or pulse irrigate so the infiltration rate of the soil is not exceeded.
  - Inspect irrigation system regularly for leaks and to ensure that excessive runoff is not occurring.
  - If re-claimed water is used for irrigation, ensure that there is no runoff from the landscaped area(s).
  - If bailing of muddy water is required (e.g. when repairing a water line leak), do not put it in the storm drain; pour over landscaped areas.
  - Use automatic timers to minimize runoff.
  - Use popup sprinkler heads in areas with a lot of activity or where pipes may be broken. Consider the use of mechanisms that reduce water flow to broken sprinkler heads.
5. **Properly store and dispose of chemicals.**
  - Implement storage requirements for pesticide products with guidance from the local fire department and/or County Agricultural Commissioner.
  - Provide secondary containment for chemical storage.
  - Dispose of empty containers according to the instructions on the container label.
  - Triple rinse containers and use rinse water as product.
6. **Properly manage pesticide and herbicide use.**
  - Follow all federal, state, and local laws and regulations governing the use, storage, and disposal of pesticides and herbicides and training of applicators and pest control advisors.
  - Follow manufacturers' recommendations and label directions.
  - Use pesticides only if there is an actual pest problem (not on a regular preventative schedule). When applicable use less toxic pesticides that will do the job. Avoid use of copper-based pesticides if possible. Use the minimum amount of chemicals needed for the job.
  - Do not apply pesticides if rain is expected or if wind speeds are above 5 mph.
  - Do not mix or prepare pesticides for application near storm drains. Prepare the minimum amount of pesticide needed for the job and use the lowest rate that will effectively control the targeted pest.
  - Whenever possible, use mechanical methods of vegetation removal rather than applying herbicides. Use hand weeding where practical.
  - Do not apply any chemicals directly to surface waters, unless the application is approved and permitted by the state. Do not spray pesticides within 100 feet of open waters.
  - Employ techniques to minimize off-target application (e.g. spray drift) of pesticides, including consideration of alternative application techniques.
  - When conducting mechanical or manual weed control, avoid loosening the soil, which could lead to erosion.
  - Purchase only the amount of pesticide that you can reasonably use in a given time period.
  - Careful soil mixing and layering techniques using a topsoil mix or composted organic material can be used as an effective measure to reduce herbicide use and watering.
7. **Properly manage fertilizer use.**
  - Follow all federal, state, and local laws and regulations governing the use, storage, and disposal of fertilizers.
  - Follow manufacturers' recommendations and label directions.
  - Employ techniques to minimize off-target application (e.g. spray drift) of fertilizer, including consideration of alternative application techniques. Calibrate fertilizer distributors to avoid excessive application.
  - Periodically test soils for determining proper fertilizer use.
  - Fertilizers should be worked into the soil rather than dumped or broadcast onto the surface.
  - Sweep pavement and sidewalk if fertilizer is spilled on these surfaces before applying irrigation water.
  - Use slow release fertilizers whenever possible to minimize leaching

**8. Incorporate the following integrated pest management techniques where appropriate:**

- Mulching can be used to prevent weeds where turf is absent.
- Remove insects by hand and place in soapy water or vegetable oil. Alternatively, remove insects with water or vacuum them off the plants.
- Use species-specific traps (e.g. pheromone-based traps or colored sticky cards).
- Sprinkle the ground surface with abrasive diatomaceous earth to prevent infestations by soft-bodied insects and slugs. Slugs also can be trapped in small cups filled with beer that are set in the ground so the slugs can get in easily.
- In cases where microscopic parasites, such as bacteria and fungi, are causing damage to plants, the affected plant material can be removed and disposed of (pruning equipment should be disinfected with bleach to prevent spreading the disease organism).
- Small mammals and birds can be excluded using fences, netting, and tree trunk guards.
- Promote beneficial organisms, such as bats, birds, green lacewings, ladybugs, praying mantis, ground beetles, parasitic nematodes, trichogramma wasps, seedhead weevils, and spiders that prey on detrimental pest species.

**Training**

1. **Train employees on these BMPs, storm water discharge prohibitions, and wastewater discharge requirements.**
2. **Educate and train employees on the use of pesticides and pesticide application techniques. Only employees properly trained to use pesticides can apply them.**
3. **Train and encourage employees to use integrated pest management techniques.**
4. **Train employees on proper spill containment and cleanup.**
  - Establish training that provides employees with the proper tools and knowledge to immediately begin cleaning up a spill.
  - Ensure that employees are familiar with the site's spill control plan and/or proper spill cleanup procedures.
  - Fact sheet IC17 discusses Spill Prevention and Control in detail.
5. **Establish a regular training schedule, train all new employees, and conduct annual refresher training.**
6. **Use a training log or similar method to document training.**

**Stencil storm drains**

Storm drain system signs act as highly visible source controls that are typically stenciled directly adjacent to storm drain inlets. Stencils should read "No Dumping Drains to Ocean".

**References**

California Storm Water Best Management Practice Handbook. Industrial and Commercial. 2003. [www.cabmphandbooks.com](http://www.cabmphandbooks.com)

California Storm Water Best Management Practice Handbooks. Industrial/Commercial Best Management Practice Handbook. Prepared by Camp Dresser & McKee, Larry Walker Associates, Uribe and Associates, Resources Planning Associates for Stormwater Quality Task Force. March 1993.

King County Stormwater Pollution Control Manual. Best Management Practices for Businesses. King County Surface Water Management. July 1995. On-line: <http://dnr.metrokc.gov/wlr/dss/spcm.htm>

Stormwater Management Manual for Western Washington. Volume IV Source Control BMPs. Prepared by Washington State Department of Ecology Water Quality Program. Publication No. 99-14. August 2001.

Water Quality Handbook for Nurseries. Oklahoma Cooperative Extension Service. Division of Agricultural Sciences and Natural Resources. Oklahoma State University. E-951. September 1999.

**For additional information contact:**

**County of Orange/ OC Watersheds**

Main: (714) 955-0600

24 hr Water Pollution Hotline: 1-877-89-SPILL

or visit our website at [www.ocwatersheds.com](http://www.ocwatersheds.com)

## IC15. PARKING AND STORAGE AREA MAINTENANCE

### Best Management Practices (BMPs)

A BMP is a technique, measure or structural control that is used for a given set of conditions to improve the quality of the stormwater runoff in a cost effective manner<sup>1</sup>. The minimum required BMPs for this activity are outlined in the box to the right. Implementation of pollution prevention/good housekeeping measures may reduce or eliminate the need to implement other more costly or complicated procedures. Proper employee training is key to the success of BMP implementation.

The BMPs outlined in this fact sheet target the following pollutants:

Targeted Constituents	
Sediment	x
Nutrients	x
Floatable Materials	x
Metals	x
Bacteria	x
Oil & Grease	x
Organics & Toxicants	x
Pesticides	x
Oxygen Demanding	x

#### MINIMUM BEST MANAGEMENT PRACTICES Pollution Prevention/Good Housekeeping

- Conduct regular cleaning.
- Properly collect and dispose of wash water.
- Keep the parking and storage areas clean and orderly.
- Use absorbent materials and properly dispose of them when cleaning heavy oily deposits.
- When conducting surface repair work cover materials and clean paintbrushes and tools appropriately.

#### Stencil storm drains

#### Training

- Train employees on these BMPs, storm water discharge prohibitions, and wastewater discharge requirements.
- Provide on-going employee training in pollution prevention.

Provided below are specific procedures associated with each of the minimum BMPs along with procedures for additional BMPs that should be considered if this activity takes place at a facility located near a sensitive waterbody. In order to meet the requirements for medium and high priority facilities, the owners/operators must select, install and maintain appropriate BMPs on site. Since the selection of the appropriate BMPs is a site-specific process, the types and numbers of additional BMPs will vary for each facility.

#### 1. Conduct regular cleaning.

- Sweeping or vacuuming the parking facility is encouraged over other methods.
- Sweep all parking lots at least once before the onset of the wet season.
- Establish frequency of sweeping based on usage and field observations of waste accumulation.

#### 2. Properly collect and dispose of wash water.

- Block the storm drain or contain runoff.
- Wash water should be collected and pumped to the sanitary sewer or discharged to a pervious surface, do not allow wash water to enter storm drains. Refer to fact sheet *IC24 Wastewater Disposal* for guidance on appropriate methods for disposal of wash water to the sanitary sewer.
- Dispose of parking lot sweeping debris and dirt at a landfill.

#### 3. Consider use of source treatment BMPs to treat runoff.

- Allow sheet runoff to flow into biofilters (vegetated strip and swale) and/or infiltration devices.
- Utilize sand filters or oleophilic collectors for oily waste in low quantities.

<sup>1</sup> EPA " Preliminary Data Summary of Urban Stormwater Best Management Practices"

4. **Keep the parking and storage areas clean and orderly.**
  - Clean out and cover litter receptacles frequently to prevent spillage.
  - Remove debris in a timely fashion.OPTIONAL:
  - Post “No Littering” signs.
5. **When cleaning heavy oily deposits:**
  - If possible, clean oily spots with absorbent materials.
  - Do not allow discharges to the storm drain.
  - Appropriately dispose of spilled materials and absorbents.
6. **When conducting surface repair work:**
  - Pre-heat, transfer or load hot bituminous material away from storm drain inlets.
  - Conduct surface repair work during dry weather to prevent contamination from contacting stormwater runoff.
  - Cover and seal nearby storm drain inlets (with waterproof material or mesh) and manholes before applying seal coat, slurry seal, etc. Leave covers in place until job is complete and clean any debris for proper disposal.
  - To avoid runoff, use only as much water as necessary for dust control.
  - Use drip pans or absorbent material to catch drips from paving equipment that is not in use. Dispose of collected material and absorbents properly.
7. **Conduct inspections on a regular basis.**
  - Designate personnel to conduct inspections of the parking facilities and stormwater conveyance systems associated with them.
  - Inspect cleaning equipment/sweepers for leaks on a regular basis.
8. **Keep accurate maintenance logs to evaluate materials removed/stored and improvements made.**
9. **Arrange rooftop drains to prevent drainage directly onto paved surfaces.**

#### Training

1. **Train employees on these BMPs, storm water discharge prohibitions, and wastewater discharge requirements.**
2. **Train employees on proper spill containment and cleanup.**
  - Establish training that provides employees with the proper tools and knowledge to immediately begin cleaning up a spill.
  - Ensure that employees are familiar with the site’s spill control plan and/or proper spill cleanup procedures.
  - Fact sheet IC17 discusses Spill Prevention and Control in detail.
3. **Provide regular training to field employees and/or contractors regarding cleaning of paved areas and proper operation of equipment.**
4. **Establish a regular training schedule, train all new employees, and conduct annual refresher training.**
5. **Use a training log or similar method to document training.**

#### Stencil storm drains

Storm drain system signs act as highly visible source controls that are typically stenciled directly adjacent to storm drain inlets. Stencils should read “No Dumping Drains to Ocean”.

## References

California Storm Water Best Management Practice Handbook. Industrial and Commercial. 2003.  
[www.cabmphandbooks.com](http://www.cabmphandbooks.com)

California Storm Water Best Management Practice Handbooks. Industrial/Commercial Best Management Practice Handbook. Prepared by Camp Dresser & McKee, Larry Walker Associates, Uribe and Associates, Resources Planning Associates for Stormwater Quality Task Force. March 1993.

King County Stormwater Pollution Control Manual. Best Management Practices for Businesses. King County Surface Water Management. July 1995. On-line: <http://dnr.metrokc.gov/wlr/dss/spcm.htm>

Model Urban Runoff Program: A How-To Guide for Developing Urban Runoff Programs for Small Municipalities. Prepared by City of Monterey, City of Santa Cruz, California Coastal Commission, Monterey Bay National Marine Sanctuary, Association of Monterey Bay Area Governments, Woodward-Clyde, Central Coast Regional Water Quality Control Board. July 1998 (Revised February 2002 by the California Coastal Commission).

Stormwater Management Manual for Western Washington. Volume IV Source Control BMPs. Prepared by Washington State Department of Ecology Water Quality Program. Publication No. 99-14. August 2001.

### For additional information contact:

#### County of Orange/ OC Watersheds

Main: (714) 955-0600

24 hr Water Pollution Hotline: 1-877-89-SPILL

or visit our website at [www.ocwatersheds.com](http://www.ocwatersheds.com)

## IC17. SPILL PREVENTION AND CLEANUP

### Best Management Practices (BMPs)

A BMP is a technique, measure or structural control that is used for a given set of conditions to improve the quality of the stormwater runoff in a cost effective manner<sup>1</sup>. The minimum required BMPs for this activity are outlined in the box to the right. Implementation of pollution prevention/good housekeeping measures may reduce or eliminate the need to implement other more costly or complicated procedures. Proper employee training is key to the success of BMP implementation.

The BMPs outlined in this fact sheet target the following pollutants:

Targeted Constituents	
Sediment	x
Nutrients	x
Floatable Materials	x
Metals	x
Bacteria	x
Oil & Grease	x
Organics & Toxicants	x
Pesticides	x
Oxygen Demanding	x

Provided below are specific procedures associated with each of the minimum BMPs along with procedures for additional BMPs that should be considered if this activity takes place at a facility located near a sensitive waterbody. In order to meet the requirements for medium and high priority facilities, the owners/operators must select, install and maintain appropriate BMPs on site. Since the selection of the appropriate BMPs is a site-specific process, the types and numbers of additional BMPs will vary for each facility.

### Spill Prevention

1. **Develop procedures to prevent/mitigate spills to storm drain systems.**  
Standardize reporting procedures, containment, storage, and disposal activities, documentation, and follow-up procedures.
2. **Post "No Dumping" signs with a phone number for reporting illegal dumping and disposal.**
3. **Conduct routine cleaning, inspections, and maintenance**
  - Sweep and clean storage areas consistently at a designated frequency (e.g. weekly, monthly). **DO NOT** hose down areas to storm drains.
  - Place drip pans or absorbent materials beneath all mounted taps, and at all potential drip and spill locations during filling and unloading of tanks. Reuse, recycle, or properly dispose of any collected liquids or soiled absorbent materials.
  - Check tanks (and any containment sumps) frequently for leaks and spills. Replace tanks that are leaking, corroded, or otherwise deteriorating with tanks in good condition. Collect all spilled liquids and properly dispose of them.

#### MINIMUM BEST MANAGEMENT PRACTICES Pollution Prevention/Good Housekeeping

- Develop procedures to prevent/mitigate spills to storm drain systems.
- Post "No Dumping" signs with a phone number for reporting illegal dumping and disposal.
- Conduct routine cleaning, inspections, and maintenance.
- Properly store and handle chemical materials.
- Protect materials stored outside from stormwater runoff.
- Secure drums stored in an area where unauthorized persons may gain access to prevent accidental spillage, pilferage, or any unauthorized use.
- Identify key spill response personnel.
- Clean up leaks and spills immediately.
- Report and track spills.

#### Stencil storm drains

#### Training

- Train employees on these BMPs, storm water discharge prohibitions, and wastewater discharge requirements.
- Provide on-going employee training in pollution prevention.

<sup>1</sup> EPA " Preliminary Data Summary of Urban Stormwater Best Management Practices"

- Check for external corrosion of material containers, structural failures, spills and overfills due to operator error, failure of piping system, etc.
  - Inspect tank foundations, connections, coatings, and tank walls and piping system.
4. **Properly store and handle chemical materials.**
    - Designate a secure material storage area that is paved with Portland cement concrete, free of cracks and gaps, and impervious in order to contain leaks and spills.
    - Do not store chemicals, drums, or bagged materials directly on the ground. Place these items in secondary containers.
    - Keep chemicals in their original containers, if feasible.
    - Keep containers well labeled according to their contents (e.g., solvent, gasoline).
    - Label hazardous substances regarding the potential hazard (corrosive, radioactive, flammable, explosive, poisonous).
    - Prominently display required labels on transported hazardous and toxic materials (per US DOT regulations).
  5. **Utilize secondary containment systems for liquid materials.**
    - Surround storage tanks with a berm or other secondary containment system.
    - Slope the area inside the berm to a drain.
    - Drain liquids to the sanitary sewer if available. **DO NOT** discharge wash water to sanitary sewer until contacting the local sewer authority to find out if pretreatment is required
    - Pass accumulated stormwater in petroleum storage areas through an oil/water separator.
    - Use catch basin filtration inserts.
  6. **Protect materials stored outside from stormwater runoff.** Construct a berm around the perimeter of the material storage area to prevent the runoff of uncontaminated stormwater from adjacent areas as well as runoff of stormwater from the material.
  7. **Secure drums stored in an area where unauthorized persons may gain access to prevent accidental spillage, pilferage, or any unauthorized use.**

#### Spill Control and Cleanup Activities

8. **Identify key spill response personnel.**
9. **Adopt the Orange County Hazardous Materials Area Plan or an equivalent plan, which includes a set of planned responses to hazardous materials emergencies. The plan should include:**
  - Description of the facility, owner and address, activities and chemicals present
  - Facility map
  - Notification and evacuation procedures
  - Cleanup instructions
  - Identification of responsible departments
10. **Clean up leaks and spills immediately.**
  - Place a stockpile of spill cleanup materials where they will be readily accessible (e.g. near storage and maintenance areas).
  - Utilize dry cleaning methods to clean up spills to minimize the use of water. Use a rag for small spills, a damp mop for general cleanup, and absorbent material for larger spills. If the spilled material is hazardous, then used cleanup materials are also hazardous and must be sent to a certified laundry (rags) or disposed of as hazardous waste. Physical methods for the cleanup of dry chemicals include the use brooms, shovels, sweepers, or plows.
  - Never hose down or bury dry material spills. Sweep up the material and dispose of properly.
  - Clean up chemical materials with absorbents, gels, and foams. Use adsorbent materials on small spills rather than hosing down the spill. Remove the adsorbent materials promptly and dispose of properly.
  - For larger spills, a private spill cleanup company or Hazmat team may be necessary.

## 11. Reporting

1. Report spills that pose an immediate threat to human health or the environment to local agencies, such as the fire department, and the Regional Water Quality Control Board.
2. Establish a system for tracking incidents. The system should be designed to identify the following:
  - Types and quantities (in some cases) of wastes
  - Patterns in time of occurrence (time of day/night, month, or year)
  - Mode of dumping (abandoned containers, "midnight dumping" from moving vehicles, direct dumping of materials, accidents/spills)
  - Responsible parties
3. Federal regulations require that any oil spill into a water body or onto an adjoining shoreline be reported to the National Response Center (NRC) at 800-424-8802 (24 hour).

## Training

1. Educate employees about spill prevention and cleanup.
  - Establish training that provides employees with the proper tools and knowledge to immediately begin cleaning up a spill.
  - Educate employees on aboveground storage tank requirements.
  - Train all employees upon hiring and conduct annual refresher training.
2. Train employees responsible for aboveground storage tanks and liquid transfers on the Spill Prevention Control and Countermeasure Plan.

## Stencil storm drains

Storm drain system signs act as highly visible source controls that are typically stenciled directly adjacent to storm drain inlets. Stencils should read "No Dumping Drains to Ocean".

## References

California Storm Water Best Management Practice Handbook. Industrial and Commercial. 2003.  
[www.cabmphandbooks.com](http://www.cabmphandbooks.com)

California Storm Water Best Management Practice Handbooks. Industrial/Commercial Best Management Practice Handbook. Prepared by Camp Dresser & McKee, Larry Walker Associates, Uribe and Associates, Resources Planning Associates for Stormwater Quality Task Force. March 1993.

Model Urban Runoff Program: A How-To Guide for Developing Urban Runoff Programs for Small Municipalities. Prepared by City of Monterey, City of Santa Cruz, California Coastal Commission, Monterey Bay National Marine Sanctuary, Association of Monterey Bay Area Governments, Woodward-Clyde, Central Coast Regional Water Quality Control Board. July 1998 (Revised February 2002 by the California Coastal Commission).

Stormwater Management Manual for Western Washington. Volume IV Source Control BMPs. Prepared by Washington State Department of Ecology Water Quality Program. Publication No. 99-14. August 2001.

## For additional information contact:

### County of Orange/ OC Watersheds

Main: (714) 955-0600

24 hr Water Pollution Hotline: 1-877-89-SPILL

or visit our website at [www.ocwatersheds.com](http://www.ocwatersheds.com)

# **Attachment B: Operations and Maintenance Plan**

# **Operation & Maintenance (O&M) Plan for WQMP WQ21-0033**

## **Project Name:**

**Dana Point Harbor Revitalization - Commercial Core Area**

## **Prepared for:**

**Dana Point Harbor Partners LLC  
610 Newport Center Drive, Suite 490  
Newport Beach, CA 92660  
949-723-7788**

## **Prepared on:**

**11/18/2021**

# Contents

Page No.

Section 1	Project Description and BMP Overview .....	1
Section 2	Personnel, Documentation, and Reporting .....	1
2.1	Maintenance Roles and Responsibilities .....	1
2.2	Qualification and Training Requirements for Personnel .....	2
2.3	Maintenance Agreements and Funding Mechanisms .....	3
2.4	Record Keeping Requirements .....	3
2.5	Required Permits Associated with Maintenance Activities .....	4
2.6	Self-Reporting Requirements.....	4
2.7	City Inspections.....	4
2.8	Electronic Data Submittal .....	4
Section 3	Inspection and Maintenance Activities .....	5
3.1	Inspection and Maintenance of Source Control BMPs .....	5
3.2	Inspection and Maintenance of Hydrologic Source Controls.....	10
3.3	Inspection and Maintenance of Structural LID and Hydromodification BMPs .....	11
3.4	Emergency Response Plan.....	14
3.5	Vector Control.....	15
Attachment 1:	Photos and Exhibits.....	16
Attachment 2:	Maintenance Agreement and Funding Mechanism Documentation .....	17
Attachment 3:	Training Log Form .....	18
Attachment 4:	Inspection and Maintenance Log Form .....	20
Attachment 5:	Inspection and O&M Checklist (Optional).....	24
Attachment 6:	Vendor O&M Information .....	25

# Section 1 Project Description and BMP Overview

General Project Attributes and Stormwater Control Measures	
Site Location	Dana Point Harbor
Project Area (ft <sup>2</sup> ): 537,095ft <sup>2</sup>	Number of Dwelling Units: 0      SIC Code: 0919, 4493
Narrative Project Description:	<p>This Project is comprised of the Commercial Core Area which covers approx. 12.33 acres within the 277-acre Dana Point Harbor.</p> <p><u>Commercial Core Area</u></p> <p>Commercial Core Area consists of 7 new two story buildings with retail, restaurants, office shell tenant space buildings with an ocean front boardwalk (located along the waterfront of the East Cove Marina). The new buildings are separated by landscape and hardscape walkways and some consist of a 2<sup>nd</sup> level deck. The proposed improvements also include multiple paved surface parking lots, and newly landscaped areas.</p> <p>The building have been numbered from 6 to 12 and range in size from 7,258 sf to 9,905 sf.</p>
Project-specific Source Control BMPs	<ul style="list-style-type: none"> <li>• Education for Property Owners, Tenants and Occupants</li> <li>• Activity Restrictions</li> <li>• Common Area Landscape Management</li> <li>• BMP Maintenance</li> <li>• Title 22 CCR Compliance (How development will comply)</li> <li>• Spill Contingency Plan</li> <li>• Hazardous Materials Disclosure Compliance</li> <li>• Uniform Fire Code Implementation</li> <li>• Common Area Litter Control</li> </ul>

## General Project Attributes and Stormwater Control Measures

- Employee Training
- Common Area Catch Basin Inspection
- Street Sweeping Private Streets and Parking Lots
- Provide storm drain system stenciling and signage
- Design and construct trash and waste storage areas to reduce pollution introduction
- Use efficient irrigation systems & landscape design, water conservation, smart controllers, and source control

Summary of Drainage  
Patterns

### Commercial Core Area

The project has been broken down into 7 major drainage areas discharging to one of three outfalls:

- Drainage area 1 consists of sub-areas C1.1 to C1.3 with a total acreage of 1.06 ac consisting of the northeast portion of the parking lot with landscape islands. Stormwater sheet flows from the parking lot to one of three Modular Wetlands Treatment Units. These Areas also have grated inlets with a highflow bypass in excess of the treatment flow rate. Low flows are diverted to the Modular Wetlands Units via a Dvert System. Stormwater is then conveyed to and underground storm drain system (Storm Drain Lateral C1). Stormwater then flows east to the backbone storm drain system ultimately discharging to Outfall 3.
- Drainage area 2 consists of sub-areas C3.2 to C3.9 with a total acreage of 3.34 ac consisting of a majority of the parking lot with landscape islands and sidewalk. Stormwater sheet flows from the parking lot to one of six Modular Wetlands Treatment Units. These Areas also have grated inlets with a highflow bypass in excess of the treatment flow rate. Low flows are diverted to the Modular Wetlands Units via a Dvert System. Area C3.5 has an internal bypass system to divert high flow directly to the stormdrain system. Stormwater is then conveyed to and underground storm drain system (Storm Drain Lateral C3). Stormwater then flows east to the backbone storm drain system ultimately discharging to Outfall 3.
- Drainage area 3 consists of sub-areas C4.1 and C4.2 with a total acreage of 1.54 ac consisting of the southwest parking lot, landscaped areas, sidewalk and roofs including overdrains and

## General Project Attributes and Stormwater Control Measures

- second floor decks. Stormwater flows from portions of Buildings 11, 10, 9 and 8 to ground level via overdrains then surface flows to the parking lot and ultimately to one of two Modular Wetlands Treatment Units. These Areas also have grated inlets with a highflow bypass in excess of the treatment flow rate. Low flows are diverted to the Modular Wetlands Units via a Dvert System. Stormwater is then conveyed to and underground storm drain system (Storm Drain Lateral C4). Stormwater then flows east to the backbone storm drain system ultimately discharging to Outfall 3.
- Drainage area 4 consists of one sub-areas C-5 with a total acreage of 0.78 ac consisting of sidewalk, landscaped areas and roofs including overdrains and second floor decks. Stormwater flows from portions of Buildings 9 & 10 either to ground level via down drains or overdrains connected to the storm drain system. Stormwater then flow to area drains and then to the underground storm drain system and treated via a StormVault with StormSafe cartridges. Stormwater then flows east to the backbone storm drain system ultimately discharging to Outfall 3.
  - Drainage area 5 consists of one sub-areas C-6 with a total acreage of 0.58 ac consisting of sidewalk, landscaped areas and roofs including overdrains and second floor decks. Stormwater flows from Building 8 to overdrains connected to the storm drain system. Surface stormwater flows to area drains and then to the underground storm drain system and treated via a StormVault with StormSafe cartridges. Stormwater then flows west to the backbone storm drain system ultimately discharging to Outfall 3.
  - Drainage area 6 consists of one sub-area D-1 with a total acreage of 3.05 ac consisting of sidewalk, landscaped areas, roofs including overdrains and second floor decks, and future improvements along the east/southeast side of D-1 (that includes buildings, a small parking lot, drive aisles, landscaping, sidewalk, etc). Stormwater flows from portions of Buildings 6 and 7 to overdrains connected to the storm drain system. Surface stormwater flows to area drains and then to the underground storm drain system (Storm Drain Lateral D) and treated via a StormVault with StormSafe cartridges. The StormVault system has been sized to also treat the abovementioned future improvements. Stormwater then flows southwest to storm drain system ultimately discharging to Outfall 4.
  - Drainage area 7 consists of sub-areas E.1 to E.7 with a total acreage of 1.98 ac consisting of the southwest portion of the parking lot, the eastern half of Casitas Place, landscape areas,

## General Project Attributes and Stormwater Control Measures

sidewalk, and roofs/decks of Building 11 and 12. Stormwater sheet flows from the parking lot and the eastern half Casitas Place drive isle to one of three Modular Wetlands Treatment Units for areas E.1 to E.5 along with Building 12. Areas E.1, E.2, E.3, and E.4 areas also have grated inlets with a highflow bypass in excess of the treatment flow rate. Low flows are diverted to the Modular Wetlands Units via a Dvert System. Stormwater is then conveyed to and underground storm drain system (Storm Drain Lateral E). Stormwater then flows south to area E.5. Stormwater from portions of Building 11 and 12 discharge to ground level via roof drains and surface flows to adjacent area. Area E.5 has an internal bypass system to divert high flow directly to the storm drain system. Stormwater is then conveyed from Lateral E. Areas E.6 & E.7 have area drains that are connected to one of two StormVault with StormSafe cartridges. These two are connected to Lateral E and then discharged to outfall 5. This DMA also includes the event lawn south of Building 11 which is designed as synthetic turf and the westerly side of Building 12 where there will be synthetic turf landscape area serving as a fire lane and an area for kayak and paddle board rentals. In addition, the southerly portions include the pedestrian boardwalk along the seawall and a treated timber boardwalk, that drains below to a storm drain collector which then takes the water to StormSafe units. These units will provide treatment for possible leached metals from the boardwalk.

Outfalls 3, 4 and 5 are piped to the ocean through existing storm drain outlets. Portion of the existing boardwalk in the Dana Wharf will sheet flow directly to the marina/harbor.

Summary of Hydrologic  
Source Controls

Where feasible, impervious area dispersion will be utilized. Calculations will be provided with final WQMP.

## **General Project Attributes and Stormwater Control Measures**

Structural Treatment and  
Hydromodification BMPs

This project will utilize two proprietary structural treatment system.

1. Modular Wetlands by BioClean
2. StormSafe by Jensen Precast

Hydromodification BMPs are not required for this project.

**WQMP Operations and Maintenance Plan**  
**Dana Point Harbor Revitalization - Marina**

<u>BMP ID</u>	<u>BMP Type</u>	<u>Narrative Description</u>	<u>Location</u>	<u>Other Considerations</u>
BMP 1	Modular Wetlands BIO-5/7	Proprietary Bio-treatment	Approx. 33°27'42.43"N 117°41'41.43"W	
BMP 2	Modular Wetlands BIO-5/7	Proprietary Bio-treatment	Approx. 33°27'42.14"N 117°41'40.26"W	
BMP 3	Modular Wetlands BIO-5/7	Proprietary Bio-treatment	Approx. 33°27'41.69"N 117°41'39.57"W	
BMP 4	Modular Wetlands BIO-5/7	Proprietary Bio-treatment	Approx. 33°27'41.48"N 117°41'44.00"W	
BMP 5	Modular Wetlands BIO-5/7	Proprietary Bio-treatment	Approx. 33°27'41.40"N 117°41'42.92"W	
BMP 6	Modular Wetlands BIO-5/7	Proprietary Bio-treatment	Approx. 33°27'40.84"N 117°41'42.30"W	
BMP 7	Modular Wetlands BIO-5/7	Proprietary Bio-treatment	Approx. 33°27'41.18"N 117°41'41.91"W	
BMP 8	Modular Wetlands BIO-5/7	Proprietary Bio-treatment	Approx. 33°27'41.57"N 117°41'40.63"W	
BMP 9	Modular Wetlands BIO-5/7	Proprietary Bio-treatment	Approx. 33°27'40.71"N 117°41'41.37"W	
BMP 10	Modular Wetlands	Proprietary Bio-treatment	Approx. 33°27'40.17"N	

**WQMP Operations and Maintenance Plan**  
**Dana Point Harbor Revitalization - Marina**

	BIO-5/7		117°41'40.21"W	
BMP 11	Modular Wetlands BIO-5/7	Proprietary Bio-treatment	Approx. 33°27'40.50"N 117°41'42.64"W	
BMP 12	StormSafe TRT-2	Proprietary Filtration Media Unit	Approx. 33°27'39.23"N 117°41'38.57"W	
BMP 13	StormSafe TRT-2	Proprietary Filtration Media Unit	Approx. 33°27'36.72"N 117°41'33.29"W	
BMP 14	StormSafe TRT-2	Proprietary Filtration Media Unit	Approx. 33°27'38.32"N 117°41'41.33"W	
BMP 15	Modular Wetlands BIO-5/7	Proprietary Bio-treatment	Approx. 33°27'37.81"N 117°41'38.58"W	
BMP 16	Modular Wetlands BIO-5/7	Proprietary Bio-treatment	Approx. 33°27'41.44"N 117°41'45.37"W	
BMP 17	Modular Wetlands BIO-5/7	Proprietary Bio-treatment	Approx. 33°27'40.97"N 117°41'44.34"W	
BMP 18	StormSafe TRT-2	Proprietary Filtration Media Unit	Approx. 33°27'40.66"N 117°41'44.91"W	
BMP 19	StormSafe TRT-2	Proprietary Filtration Media Unit	Approx. 33°27'39.04"N 117°41'44.32"W	

## **Section 2 Personnel, Documentation, and Reporting**

### **2.1 Maintenance Roles and Responsibilities**

The roles related to O&M of the BMPs are defined as follows:

- **Facility Owner** – *The Facility Owner is the party who is ultimately responsible for the functionality of all BMPs. The maintenance agreement (Attachment 2) identifies the facility owner for each BMP, including the timing of any ownership transitions.*
- **Responsible Party** – *The Responsible Party is the party that shall have direct responsibility for the O&M of the BMPs. This party shall be the designated contact with inspectors and lead maintenance personnel. The Responsible Party shall sign self-inspection reports and any correspondence regarding the verification of inspections and required maintenance. The Responsible Party will establish a system to delegate general inquiries to the appropriate maintenance personnel concerning the operation and maintenance of the BMPs. The Responsible Party reports directly to the Facility Owner and operates and manages the BMPs on the Facility Owner’s behalf.*
- **Designated Emergency Respondent** – *The Designated Emergency Respondent is the party responsible for directing activities and communications during emergencies such as broken irrigation pipes, landslides, hazardous spill responses etc., that would require immediate response should they occur during off-hours. It is the responsibility of the Designated Emergency Respondent to communicate the emergent situation with the Responsible Party as soon as possible.*
- **Key Maintenance Personnel** – *Key Maintenance Personnel are the designated lead field manager(s) or supervisor(s) who directly oversee and delegate the maintenance activities, maintain the scheduling, and coordinate activities between all personnel. These tend to change more often than other personnel over time, so their names do not necessarily need to be included in the O&M Plan. However, they must be properly trained as recorded in the training logs (Section 2.2).*

The table below lists the roles for this project. This table must be updated whenever changes occur.

Role	Name (Title and Affiliation)	Phone Number	Address	Email Address
Facility Owner	County of Orange	714-834- 3767	333 W. Santa Ana Blvd., Suite 144  Santa Ana, CA 92701	james.campbell@ocgov.com
Responsible Party	Dana Point Harbor Partners, LLC	949-760- 9150	111 Newport Center Dr., Suite 200  Newport Beach, CA 92660	jueberroth@bellwetherfinancialgroup.com

Designated Emergency Respondent	Joe Ueberroth	949-723- 7788	610 Newport Center Dr., Suite 490  Newport Beach, CA 92660	jueberroth@bellwetherfinancialgroup.com
---------------------------------------	---------------	------------------	--	---

## 2.2 Qualification and Training Requirements for Personnel

Many of the activities presented in this O&M plan can be completed by personnel with basic landscaping and yard maintenance skills and project-specific orientation. However, there are activities that require a more experienced skillset to identify and remediate potential issues that could compromise the functionality of each BMP. The Responsible Party shall exercise discretion in determining the skillset required to complete each task.

Activities that can typically be completed by maintenance personnel with basic training and/or qualifications include:

- General landscaping activities (pruning, weeding, and raking)
- Routine sediment, trash and debris removal;
- Filling in minor scour or erosion areas, or replacing rip rap that has become displaced; and
- Watering or irrigation, as necessary.

Activities that typically require maintenance personnel with specialized qualifications, training, and/or engineering oversight include:

- Inspection and/or repair of inflow and outflow structures;
- Inspection and/or repair of underground elements;
- Large-volume sediment or media removal requiring specialized equipment;
- Inspection, diagnosis, and remediation of significant erosion issues potentially compromising function and/or structural stability; and
- Spill response and remediation.

Maintenance personnel who have identified a potential major issue with any facility should contact the designated key maintenance personnel for the facility immediately.

Training must be provided for all personnel performing maintenance tasks on or providing maintenance oversight of structural BMPs. The table below provides the personnel and relevant training topics.

Training Logs contained in Attachment 3 should be used to document training of maintenance personnel.

Training Topic	Responsible Party	Designated Emergency Respondent	Key Maintenance Personnel
Proper Maintenance of all BMP components	X		X
Identification and clean-up procedures for spills and overflows	X	X	X
Safety concerns when maintaining devices and responding to emergency situations	X	X	X

### **2.3 Maintenance Agreements and Funding Mechanisms**

Dana Point Harbor Partner’s LLC. will provide the long term funding and maintenance for BMP’s. Since, DPHP LLC. will be responsible for the long term maintenance of the project’s BMPs, no maintenance agreement is required. The funding will be provided in accordance with the long term lease agreement between the DPHP LLC. and the County of Orange.

### **2.4 Record Keeping Requirements**

Documentation of site conditions, maintenance activities performed, and any other remaining maintenance required is necessary during each inspection/maintenance visit. Inspection and maintenance records shall be retained in an accessible, secure location for the life of the facility, and not less than 10 years.

The following documentation mechanisms and procedures have been established for this O&M Plan:

- **Training Logs:** Personnel must document training activities as part of implementing this O&M Plan. Attachment 3 contains a sample training log.
- **Inspection and Routine Maintenance Logs:** Maintenance personnel are required to maintain logs of inspection and maintenance activities. Attachment 4 contain inspection and maintenance logs.
- **Rehabilitative and Corrective Maintenance Log and Reporting:** Rehabilitation and corrective maintenance activities should be documented at a degree of detail that is

commensurate to the complexity/significance of the activity. Any significant changes to the BMP designs that arise from rehabilitation/corrective maintenance will be documented via an update to the Project WQMP and as-built drawings. Corrective maintenance that does not result in design changes will be documented as a special entry in the maintenance logs to provide pertinent details of that rehabilitative or corrective maintenance activity.

At this time, the City or other agencies do not require a monitoring plan.

## **2.5 Required Permits Associated with Maintenance Activities**

At this time, no additional permit are required for the implementation, operation, and maintenance of the BMPs.

## **2.6 Self-Reporting Requirements**

At this time, no additional self-reporting requirement are required from the local jurisdiction.

## **2.7 City Inspections**

The City of Dana Point may conduct a site inspection to evaluate compliance with the Project WQMP, at any time, in accordance with Dana Point Municipal Code 15.10.

## **2.8 Electronic Data Submittal**

This document, along with the attachments, shall be provided to the City or County in PDF format. Autocad files and/or GIS coordinates of BMPs shall also be submitted to the City/County.

## **Section 3      Inspection and Maintenance Activities**

This section identifies the inspection and O&M activities for each BMP incorporated into the project. Section 3.1 and 3.2 contain common maintenance activities and frequencies associated with Source Control BMPs and HSCs, respectively. Section 3.3 contains individual tables for each structural LID or hydromodification BMP with an explanation of the various types of maintenance activities associated with these BMPs.

### **3.1      Inspection and Maintenance of Source Control BMPs**

<b>Source Control BMP</b>	<b>Activity</b>	<b>Frequency</b>
Dry Weather Flow Source Control  <b>Note: this is a South Orange County High Priority Water Quality Condition for All Projects</b>	Check for dry weather flows such as street washing, irrigation overspray, air conditioner condensate in areas of the project that do not drain to LID BMPs, the sanitary sewer, or landscaped pervious areas. Notify residents of any dry weather flows and follow up to correct.	Twice per year during dry season
	Inspect project outfall or most-downstream project manhole for presence of dry weather flow. If present, conduct reconnaissance to determine source and implement actions to eliminate source.	Twice per year during dry season
N1. Education for Property Owner's Tenants and Occupants	Distribute appropriate materials to owners, tenants, and/or occupants via contract language, mailings, website, or meetings.	Information provided to owners and tenants upon sale or lease. Reminders sent or posted as needed.
	Check <a href="http://www.ocwatersheds.com">www.ocwatersheds.com</a> and/or City website for updated educational materials.	Annually

Source Control BMP	Activity	Frequency
N2. Activity Restrictions	<p>Within the CC&amp;R's or lease agreement, restrict the following activities:</p> <ul style="list-style-type: none"> <li>-Prohibit discharges of fertilizer, pesticides, or animal wastes to streets or storm drains.</li> <li>-Prohibit blowing or sweeping of debris (leaf litter, grass clippings, litter, etc.) into parking lots or storm drains.</li> <li>-Requirement to keep dumpster lids closed at all times.</li> <li>-Prohibit vehicle washing, maintenance, or repair on the premises or restrict those activities to designated areas.</li> </ul>	Information provided to owners and tenants upon sale or lease. Reminders sent or posted as needed.
N3/S4. Common Area Landscape Management, Efficient Landscape Design, and Efficient Irrigation	Check that fertilizer and pesticide usage is in accordance with the Integrated Pest Management Program. Adjust, if needed.	Annually
	Check the irrigation system water budget to ensure efficiency targets are being met and the system is in good condition. Adjust/repair irrigation system and controllers, if needed.	Annually prior to irrigation system activation
	Check landscaping for presence of invasive species and remove, if needed.	Annually
N11. Common Area Litter Control	Remove trash from around trash enclosure, inspect to ensure lids closed, structurally sound, and not overflowing. Repair or replace, as needed.	Monthly
	Inspect common area for litter and trash disposal violations by homeowners and reporting to the POA or responsible party for investigation. Remove litter, as needed.	Weekly

**WQMP Operations and Maintenance Plan**  
**Dana Point Harbor Revitalization - Marina**

Source Control BMP	Activity	Frequency
N14. Common Area Catch Basin Inspection	Remove trash and debris from catch basins and grates. Check for damage, clogging, and standing water. Repair or mitigate clogging/standing water, as needed.	Four times per year during wet season, including inspection just before the wet season and within 24 hours after at least two storm events >0.5 inches
N15. Street Sweeping Private Streets and Parking Lots	Sweep curb and gutter areas using a vacuum street sweeper. Report any significant or illicit debris in curb/gutter to POA or responsible party, as needed.	Weekly to Monthly
S1. Provide Storm Drain System Stenciling and Signage	Check that all catch basins in paved areas marked or stenciled with “No dumping-Drains to Ocean; No Descargue Basura” language. Replace/repaint markings if faded, damaged, removed, or otherwise illegible.	Annually
S3. Design and Construct Trash and Waste Storage Areas	Check that outdoor waste storage structure is consistently covered, that structural stability is sound, and that no run-on or contact of the trash with runoff is occurring. Repair leaks or damage and mitigate if trash coming into contact with stormwater, as needed.	Twice per year
	Check that trash is removed by local waste management contractor on at least a weekly basis for proper disposal.	Weekly

<p>S4 Efficient Irrigation Systems &amp; Landscape Design, Water Conservation, Smart Controllers, and Source Control</p>	<p>All irrigation systems will be inspected to ensure that the systems are functioning properly and that the programmable timers are set correctly.</p> <p>Timing and application methods of irrigation water shall be designed to minimize the runoff of excess irrigation water into the municipal storm drain system. The following methods to reduce excessive irrigation runoff shall be incorporated in common areas of development:</p> <ol style="list-style-type: none"> <li>1. Employing rain shutoff devices to prevent irrigation after precipitation.</li> <li>2. Designing irrigation systems to each landscape area's specific water requirements.</li> <li>3. Using flow reducers or shutoff valves triggered by a pressure drop to control water loss in the event of broken sprinkler heads or lines.</li> <li>4. Implementing landscape plan consistent with County Water Conservation Resolution or city equivalent, which may include provision of water sensors, programmable irrigation times (for short cycle), etc.</li> <li>5. The timing and application methods or irrigation water shall be designed to minimize the runoff of excess irrigation water into the municipal storm drain system.</li> <li>6. Employing other comparable, equally effective, methods to reduce irrigation water runoff.</li> <li>7. Group plants with similar water requirements in order to reduce excess irrigation runoff and promote surface filtration. Choose</li> </ol>	<p>Continually</p>
--	---	--------------------

Source Control BMP	Activity	Frequency
	<p>plants with low irrigation requirements (for example, native or drought tolerant species). Consider other design features, such as:</p> <ul style="list-style-type: none"> <li>• Use mulches (such as wood chips or shredded wood products) in planter areas without ground cover to minimize sediment in runoff.</li> <li>• Install appropriate plant materials for the location, in accordance with amount of sunlight and climate, and use native plant material where possible and/or as recommended by the landscape architect.</li> <li>• Leave a vegetative barrier along the property boundary and interior watercourse, to act as a pollutant filter, where appropriate and feasible.</li> <li>• Choose plants that minimize or eliminate the use of fertilizer or pesticides to sustain growth.</li> </ul>	

### **3.2 Inspection and Maintenance of Hydrologic Source Controls**

<b>HSCs</b>	<b>Activity</b>	<b>Frequency</b>
Impervious Area Dispersion (E.g. Downspout Disconnect, Sheet Flow Dispersion)	Confirm presence of HSC. Remove trash from pervious area. Check pervious area erosion, channelization, loss of vegetation. Check downspout and flow spreader for damage or clogging. Decompact, level, reseed, or other activities, as needed, to restore functionality.	Annually

### **3.3 Inspection and Maintenance of Structural LID and Hydromodification BMPs**

The section is organized by type of structural LID or hydromodification BMP with separate tables for each BMP type included in the project. The section identifies four categories of activities related to O&M of the BMPs:

**General Inspections** - Evaluations conducted at regularly scheduled intervals to indicate the need for maintenance of structural BMPs.

**Routine Maintenance Activities** - Activities conducted at regularly scheduled intervals to sustain long-term performance of each BMP, including inspections and normal upkeep.

**Corrective (Major) Maintenance Activities** - Includes activities conducted to replace or rehabilitate system components at the end of their usable life as well as activities conducted to resolve major issues that are not anticipated.

**Emergency Response Activities** - Activities related to emergencies, primarily concerning spills, which may require immediate action and notifications (Section 3.4).

<b>BMP ID</b>	<b>BMP Type</b>	<b>Reference Maintenance Table</b>
BMP 1-11	Modular Wetlands Units	Manufacturer O&M Manual (Attachment 6)
BMP 12-14	StormSafe	Manufacturer O&M Manual (Attachment 6)
BMP 15-17	Modular Wetlands Units	Manufacturer O&M Manual (Attachment 6)
BMP 18-19	StormSafe	Manufacturer O&M Manual (Attachment 6)

<b>BIO-5/7 Proprietary Biotreatment</b>	
Activity	Frequency
GENERAL INSPECTIONS	
Remove trash and debris	Four times per year during wet season, including inspection just before the wet season and within 24 hours after at least two storm events $\geq 0.5$ inches.
Identify excess erosion or scour	
Identify sediment accumulation that requires maintenance	
Inspect during storm event, when possible, to estimate treatment capacity and determine if premature bypass is occurring	
Evaluate plant health and need for corrective action	
Identify any needed corrective maintenance that will require site-specific planning or design	
OPERATION AND MAINTENANCE	
<ul style="list-style-type: none"> <li>• O&amp;M of proprietary BMPs must follow established manufacturer guidelines</li> <li>• O&amp;M of accompanying retention BMPs should follow the guidelines established in the associated fact sheet for that BMP.</li> </ul>	

<b>TRT-2 Proprietary Treatment Control BMPs</b>	
Activity	Frequency
GENERAL INSPECTIONS	
Remove trash and debris	Four times per year during wet season, including inspection just before the wet season and within 24 hours after at least two storm events $\geq 0.5$ inches
Identify excess erosion or scour	
Identify sediment accumulation that requires maintenance	
Inspect during storm event, when possible, to estimate treatment capacity and determine if premature bypass is occurring	
Identify any needed corrective maintenance that will require site-specific planning or design	
OPERATION AND MAINTENANCE	
O&M of proprietary treatment control BMPs must follow established manufacturer guidelines	

### **3.4 Emergency Response Plan**

In some cases, adverse conditions may occur which could be an imminent threat to human or environmental health or severe damage to infrastructure or property. For example, a spill of hazardous substances in the contributing area to a BMP could cause harmful substances to enter the BMP and be released downstream, affecting environmental and public health. Other emergencies could arise related to the stormwater features or water quality protection, such as landsliding, major erosion, or burst pipes in the tributary area.

In the event of an actual or suspected hazardous material release, the following plan shall take effect.

The primary importance of initial response to an actual or suspected spill will be public safety, control of the source of pollution, and containment of spills that have occurred, as applicable. The table below provides the emergency contact information for hazardous materials spills affecting BMPs.

Name	Phone	When to Report
Local Emergency Response (Fire Department)	911	Immediately
Orange County 24-Hour Water Pollution Problem Reporting Hotline	1-877-897-7455	Immediately
CalOES State Warning Center	1-800-852-7550	Immediately

The first number to call is emergency response (9-1-1), followed by the California Governor’s Office of Emergency Services (CalOES), formerly the California Emergency Management Agency (CalEMA). (CalOES) maintains guidance and instructions of what to do in the event of a spill of hazardous substances (<http://www.caloes.ca.gov/cal-oes-divisions/fire-rescue/hazardous-materials/spill-release-reporting>). This plan is based on the guidance provided by CalOES (CalOES, 2014).

1. If an actual or suspected hazardous material incident exists, maintenance personnel will immediately call 911 and the CalOES State Warning Center <https://www.caloes.ca.gov/cal-oes-divisions/warning-center>
2. The Designated Emergency Respondent and Responsible Party assigned to the facility (from Section 2.1) must also be notified of any actual or potential spill.
3. Remediation of contamination in the water quality facility should be handled as a corrective maintenance issue per Section 3.2 of this O&M plan.

In the event that a potential spill is identified prior to it reaching the BMPs, the Designated Emergency Respondent will implement an isolation protocol to prevent the spill from entering the BMP. An inflatable plug, Hazmat Plug, or equivalent device as approved by the Designated Emergency Respondent will be installed within the storm drains or catch basins to block upstream flow from reaching and contaminating the BMP. The temporary plug will be an interim measure until the spill is properly maintained and remediated and the Designated Emergency Respondent has determined the risk to the BMP of contamination no longer exists.

Similar measures should be taken in the event of a landslide, mudslide, or major erosion within the tributary area of the BMP to prevent sediment from damaging the BMP to the extent possible.

### **3.5 Vector Control**

In addition to the inspection and maintenance activities listed in Section 3, all BMPs shall be inspected for standing water on a regular basis. Standing water which exists for longer than 72 hours may contribute to mosquito breeding areas. Standing water may indicate that the BMP is not functioning properly and proper action to remedy the situation shall be taken in a timely manner.

Elimination of standing water and managing garbage, lawn clippings, and pet droppings can help decrease the present of mosquitoes and flies in the area.

The Orange County Vector Control District may be contacted for more information and support at 714-971-2421 or 949-654-2421 or [www.ocvcd.org](http://www.ocvcd.org).

# **Attachment 1: Photos and Exhibits**

To be provided with Final WQMP

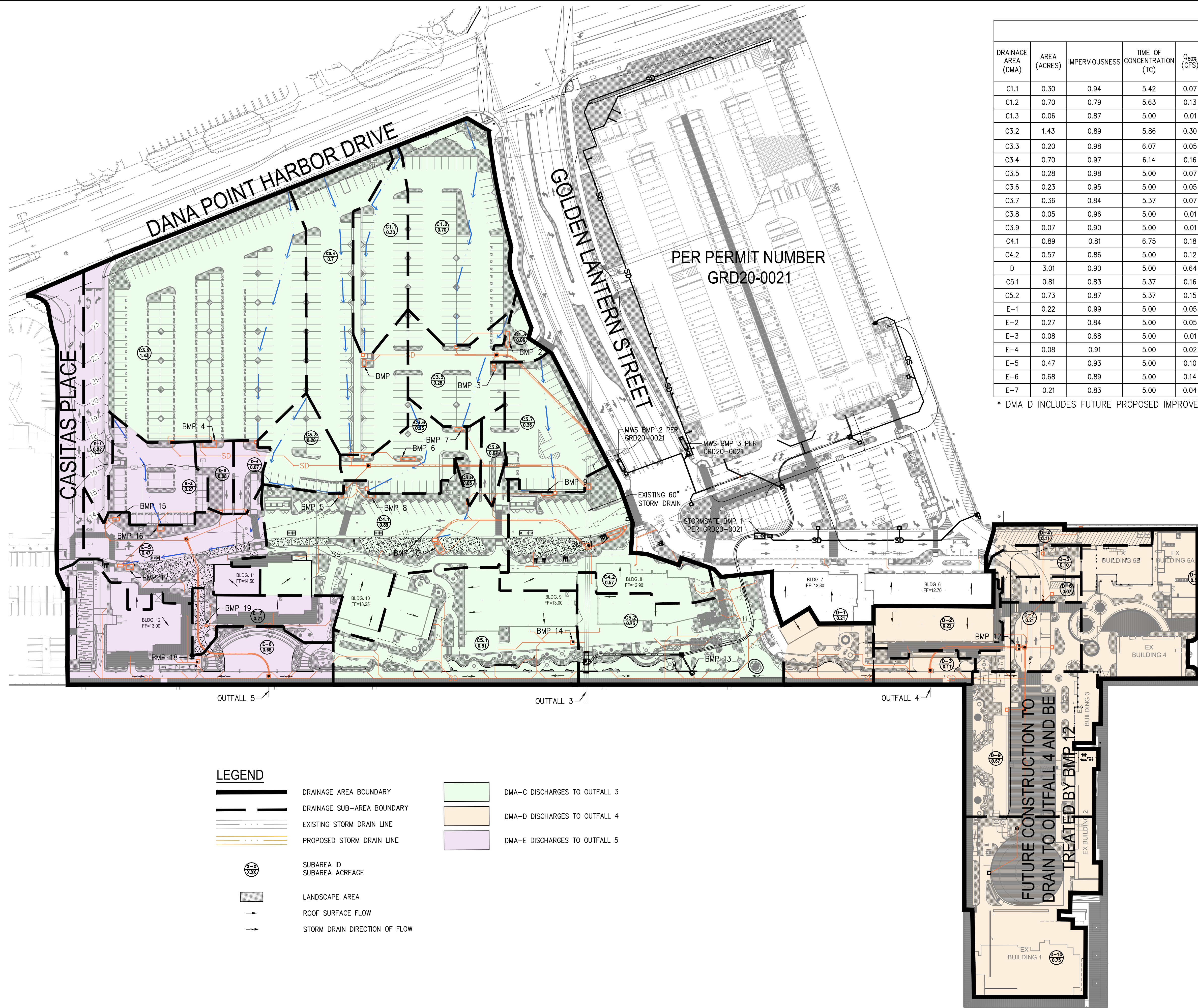

DRAINAGE MANAGEMENT AREA SUMMARY												
DRAINAGE AREA (DMA)	AREA (ACRES)	IMPERVIOUSNESS	TIME OF CONCENTRATION (TC)	Q <sub>0.05</sub> (CFS)	Q <sub>0.025</sub> (CFS)	BEST MANAGEMENT PRACTICE (BMP)	BMP TYPE	BMP MODEL	BMP SIZING	FLOW TREATMENT CAPACITY (CFS)	No. OF INLETS W/ DIVERT	OUTFALL LOCATION
C1.1	0.30	0.94	5.42	0.07	0.1	1	MWS	L-4-8-V	5' x 9'	0.1	YES (1)	OUTFALL 3
C1.2	0.70	0.79	5.63	0.13	0.202	2	MWS	L-4-19-V	5' x 20'	0.202	YES (1)	OUTFALL 3
C1.3	0.06	0.87	5.00	0.01	0.019	3	MWS	L-4-4-V	5' x 5'	0.019	YES (1)	OUTFALL 3
C3.2	1.43	0.89	5.86	0.30	0.457	4	MWS	L-8-16-V HC=3.6	9' x 17'	0.462	YES (2)	OUTFALL 3
C3.3	0.20	0.98	6.07	0.05	0.069	5	MWS	L-4-6-V	4' x 6'	0.069	YES (1)	OUTFALL 3
C3.4	0.70	0.97	6.14	0.16	0.239	6	MWS	L-4-17-V	5' x 18'	0.239	YES (1)	OUTFALL 3
C3.5	0.28	0.98	5.00	0.07	0.104	7	MWS	L-4-8-C	5' x 9'	0.105	NO	OUTFALL 3
C3.6	0.23	0.95	5.00	0.05	0.077	8	MWS	L-4-8-V	5' x 9'	0.078	YES (1)	OUTFALL 3
C3.7	0.36	0.84	5.37	0.07	0.110						YES (1)	
C3.8	0.05	0.96	5.00	0.01	0.017	9	MWS	L-4-13-V	5' x 14'	0.148	YES (1)	OUTFALL 3
C3.9	0.07	0.90	5.00	0.01	0.022						YES (1)	
C4.1	0.89	0.81	6.75	0.18	0.264	10	MWS	L-8-12-V	9' x 13'	0.265	YES (1)	OUTFALL 3
C4.2	0.57	0.86	5.00	0.12	0.177	11	MWS	L-4-17-V	5' x 18'	0.177	YES (1)	OUTFALL 3
D	3.01	0.90	5.00	0.64	0.967	12	STORMSAFE	STORMFILTER	10 PACK	2.56	-	OUTFALL 4
C5.1	0.81	0.83	5.37	0.16	0.245	14	STORMSAFE	STORMFILTER	3 PACK	0.768	-	OUTFALL 3
C5.2	0.73	0.87	5.37	0.15	0.228	13	STORMSAFE	STORMFILTER	3 PACK	0.768	-	OUTFALL 3
E-1	0.22	0.99	5.00	0.05	0.077	15	MWS	L-4-8-V	5' x 9'	0.078	YES (1)	OUTFALL 5
E-2	0.27	0.84	5.00	0.05	0.082						YES (1)	
E-3	0.08	0.68	5.00	0.01	0.021	16	MWS	L-6-8-C W/ 2 PIPE INLETS	7' x 9'	0.129	YES (1)	OUTFALL 5
E-4	0.08	0.91	5.00	0.02	0.026						-	
E-5	0.47	0.93	5.00	0.10	0.155	17	MWS	L-6-8-C	7' x 9'	0.155	YES (1)	OUTFALL 5
E-6	0.68	0.89	5.00	0.14	0.217	18	STORMSAFE	STORMFILTER	3 PACK	0.768	-	OUTFALL 5
E-7	0.21	0.83	5.00	0.04	0.063	19	STORMSAFE	STORMFILTER	1 PACK	0.256	-	OUTFALL 5

\* DMA D INCLUDES FUTURE PROPOSED IMPROVEMENTS FOR THE DESIGN OF STORMSAFE UNIT BMP 12.

NOTES:

- PROJECT IS EXEMPT FROM HYDROLOGIC CONDITION OF CONCERN (HCO). SEE SECTION 3.5 IN WQMP REPORT.
- DESIGN CAPTURE VOLUME (DCV) IS NOT APPLICABLE. FLOW-BASED DESIGN USED.

LEGEND

- DRAINAGE AREA BOUNDARY
- DRAINAGE SUB-AREA BOUNDARY
- EXISTING STORM DRAIN LINE
- PROPOSED STORM DRAIN LINE
- SUBAREA ID
- SUBAREA ACREAGE
- LANDSCAPE AREA
- ROOF SURFACE FLOW
- STORM DRAIN DIRECTION OF FLOW
- DMA-C DISCHARGES TO OUTFALL 3
- DMA-D DISCHARGES TO OUTFALL 4
- DMA-E DISCHARGES TO OUTFALL 5

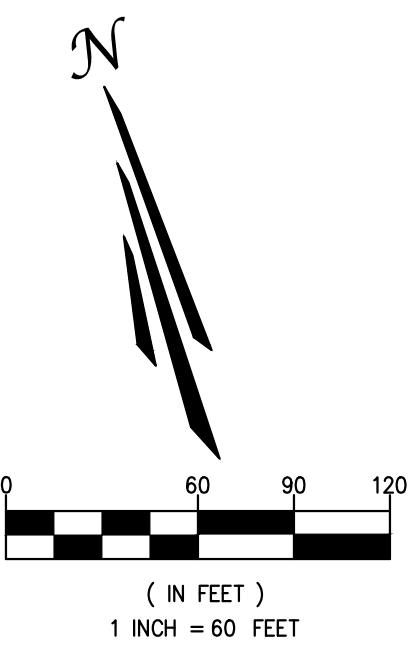

NO.	DATE	REVISIONS	ENGR.	APPROV.	DATE
7					
6					
5					
4					
3					
2					
1					

PREPARED UNDER THE SUPERVISION OF:

**TAIT**  
Since 1964

701 N. Parkcenter Drive  
Santa Ana, CA 92705  
p: 714/560/8200 f: 714/560/8211  
www.tait.com

Los Angeles Sacramento San Francisco Dallas Phoenix  
Ontario San Diego Boise Denver Portland

DESIGN ENGINEER R.C.E. No. 9/12/22 DATE

DRAWN BY:	DATE:
DESIGNED BY:	DATE:
CHECKED BY:	DATE:
RECOMMENDED BY:	DATE:

DANA POINT HARBOR REVITALIZATION

DANA POINT HARBOR PARTNERS, LLC



BUILDINGS 6-12 AND SURFACE PARKING LOT  
PRECISE GRADING PLANS

COMMERCIAL CORE DMA EXHIBIT

## **Attachment 2: Maintenance Agreement and Funding Mechanism Documentation**

Dana Point Harbor Partner's LLC. will provide the long term funding and maintenance for BMP's. Since, DPHP LLC. will be responsible for the long term maintenance of the project's BMPs, no maintenance agreement is required. The funding will be provided in accordance with the long term lease agreement between the DPHP LLC. and the County of Orange.

# **Attachment 3: Training Log Form**

**TRAINING / EDUCATIONAL LOG**

Date of Training/Educational Activity: \_\_\_\_\_

Name of Person Performing Activity  
(Printed): \_\_\_\_\_

Signature: \_\_\_\_\_

Topic of Training/Educational Activity:  
\_\_\_\_\_  
\_\_\_\_\_

Name of Participant	Signature of Participant

For newsletter or mailer educational activities, please include the following information:

- Date of mailing:
- Number distributed:
- Method of distribution:
- Topics addressed:

If a newsletter article was distributed, please include a copy of it.

# **Attachment 4: Inspection and Maintenance Log Form**

**BMP OPERATION & MAINTENANCE LOG**

**Dana Point Harbor Revitalization - Commercial Core Area**

Today's Date: \_\_\_\_\_

Name of Person Performing Activity  
(Printed): \_\_\_\_\_

Signature: \_\_\_\_\_

BMP Name or Type (As Shown in O&M Plan)	Brief Description of Operation, Maintenance, or Inspection Activity Performed	Summary of Notable Observations or Outcomes from Activity
BMP-1		
BMP-2		
BMP-3		
BMP-4		
BMP-5		
BMP-6		

**WQMP Operations and Maintenance Plan**  
Dana Point Harbor Revitalization - Marina

---

---

<b>BMP Name or Type (As Shown in O&amp;M Plan)</b>	<b>Brief Description of Operation, Maintenance, or Inspection Activity Performed</b>	<b>Summary of Notable Observations or Outcomes from Activity</b>
BMP-7		
BMP-8		
BMP-9		
BMP-10		
BMP-11		
BMP-12		
BMP-13		
BMP-14		

**WQMP Operations and Maintenance Plan**  
Dana Point Harbor Revitalization - Marina

---

---

<b>BMP Name or Type (As Shown in O&amp;M Plan)</b>	<b>Brief Description of Operation, Maintenance, or Inspection Activity Performed</b>	<b>Summary of Notable Observations or Outcomes from Activity</b>
BMP-15		
BMP-16		
BMP-17		
BMP-18		
BMP-19		

# Attachment 5: Inspection and O&M Checklist (Optional)

*Guidance: Based on the BMPs present at the site, this checklist is intended to summarize the activities necessary at each frequency. Include more details if desired.*

<b>Weekly Activities</b>	<b>Check Box</b>
Selected source control/housekeeping activities (See Section 3.1)	
<b>Monthly Activities</b>	
Selected source control/housekeeping activities (See Section 3.1)	
<b>Quarterly Activities            (before wet season, after wet season, plus twice after rain &gt; 0.5 inches)</b>	
Inspections of selected source control BMPs (See Section 3.1)	
Inspections and as-needed minor maintenance of all structural treatment and hydromodification BMPs (See Section 3.3)	
<b>Twice Yearly Activities            (during dry weather)</b>	
Dry weather flow inspections (non-structural source control) (See Section 3.1)	
Inspection and as-needed maintenance of other selected source control BMPs(See Section 3.1)	
<b>Annual Activities</b>	
Self-certification (See Section 2.6)	
Various source control BMP and housekeeping activities (See Section 3.1)	
Inspection and maintenance of HSCs (See Section 3.2)	
Various planned maintenance activities of treatment and hydromodification BMPs, such as vegetation maintenance, minor sediment maintenance, etc. (See Section 3.3)	

## **Attachment 6: Vendor O&M Information**



# StormSafe 4C

## Storm water Filtration Chamber

# Inspection And Maintenance Guide

### Important:

- Inspection and maintenance to be performed by qualified personnel only.
- Helical filter replacement may require personnel properly trained for confined space activity in accordance with local and OSHA regulations.

66 Central Ave • Farmingdale New York 11735  
Tel: (631) 393-6024 • Fax: (631) 501-5528 • Web: [www.fabco-industries.com](http://www.fabco-industries.com)

## Inspection and Cleaning Overview

The StormSafe-4C, like any other storm water remediation device, requires regular maintenance intervals to remain effective as a storm water filter. Since maintenance requirements and frequency are dependent on the pollutant load characteristics of each site, Fabco recommends a regular inspection and maintenance regime to maintain peak performance of the cartridge filters. As required, both the influent and effluent chambers should be cleaned of any collected oil, trash, debris and sediment that may inhibit filter performance.

## Recommended Cleaning Frequency

Site conditions will determine the required cleaning frequency to maintain peak performance of the StormSafe-4C treatment chamber. There is no universal rule to predict the optimal cleanout cycle for storm water filter systems; however locations with stabilized surface conditions will require less frequent cleaning than areas exposed to erosion or construction. Over a short period of time, regular inspection by maintenance personnel will dictate the appropriate cleaning frequency. For new installations, Fabco recommends at least two (2) inspections per year. Additional inspections are recommended following major rain events. Cleaning and filter replacement should be "as needed" based on these inspections. Fabco recommends an initial filter replacement frequency of once per year until sufficient historical data predicts otherwise.

## In Case of Spills

In the event of a spill, all inspection and cleaning operations should be aborted until trained HAZMAT personnel secure the jobsite.

## Included Reference Material

StormSafe-4C Detail (Figure 1), Maintenance Log Sheet

## Visual Inspection Procedure

Inspection and cleaning should be performed only after NO rainfall for at least 24 hours.  
If working in the street, wear proper safety equipment and follow the local road safety rules & regulations.  
Begin by removing both the 36" manhole access cover located over the influent and effluent chambers of the StormSafe-4C. Allow several minutes for the system to vent.  
**CAUTION:** Grates are extremely heavy. Some type of lifting mechanism is high recommended.

---

Visually inspect both chambers for heavy sediment, trash and debris loading that may limit or prevent water flow into the filter housing. A battery powered flashlight or droplight is recommended for thorough inspection.  
Some telltale signs that cleaning or filter replacement is necessary are as follows:  
Waterline marks less than 12-in below the top of the bypass weir.  
Water level differential between the influent chamber and effluent chamber.  
Obvious heavy loading of leaves, sticks or construction debris.  
Record observations and comments on the maintenance log sheet. In addition, the use of digital photographs and/or sketches may be warranted to maintain the most accurate historical records.

## Cleaning and Filter Replacement

If cleaning or replacing a filter is deemed necessary, the following procedure is recommended:

1. Secure the worksite with the appropriate safety equipment in accordance with local and OSHA regulations.
2. Remove the 36" manhole access cover located over the influent and effluent chambers of the StormSafe-4C. Allow several minutes for the chambers to vent.
3. Perform an internal and external visual inspection of the vault's general condition including the access manhole cover and casting, as well as any exposed concrete surfaces. Record any visual anomalies such as cracks, gouges, hollows, excess wear and settling.
4. Without entering the vault, both the influent and effluent chambers can be cleaned using a typical vacuum truck or similar vacuum equipment with sufficient storage capacity.
5. Both the influent and effluent chambers are designed to accommodate standard suction hoses typical to vacuum equipment. Thoroughly vacuum liquids, debris sediment from both chambers.
6. If filter replacement is deemed unnecessary, reinstall the 36" manhole access cover. Clean the jobsite as necessary and record pertinent information on the attached "Maintenance Log Sheet" to complete the job.
7. If filter replacement is deemed necessary, vault entry is required and OSHA rules for confined space entry may be required. Check local regulations and proceed accordingly.
8. Removal of the filters is done from the influent chamber. Due to possible slippery floor conditions, care should be taken to avoid falls.
9. Use a ladder if necessary, enter the influent chamber and start by twisting and lifting one of the four cartridge filters in a **counter-clockwise** direction.
10. Repeat until all four filters have been removed, proceed to inspect and clean the cartridge openings to ensure correct fit for the new set of cartridge filters.

## Disposal

All removed water, oils, sediment, debris, trash and other accumulates collected in the StormSafe must be handled and disposed of in accordance with local, state and federal regulations.

Disposal considerations must be part of a well-planned and scheduled vault maintenance regime. Solid waste disposal can typically be coordinated with a local landfill, whereas liquid waste can be disposed of at either a wastewater treatment plant, or a municipal vacuum truck decant facility.

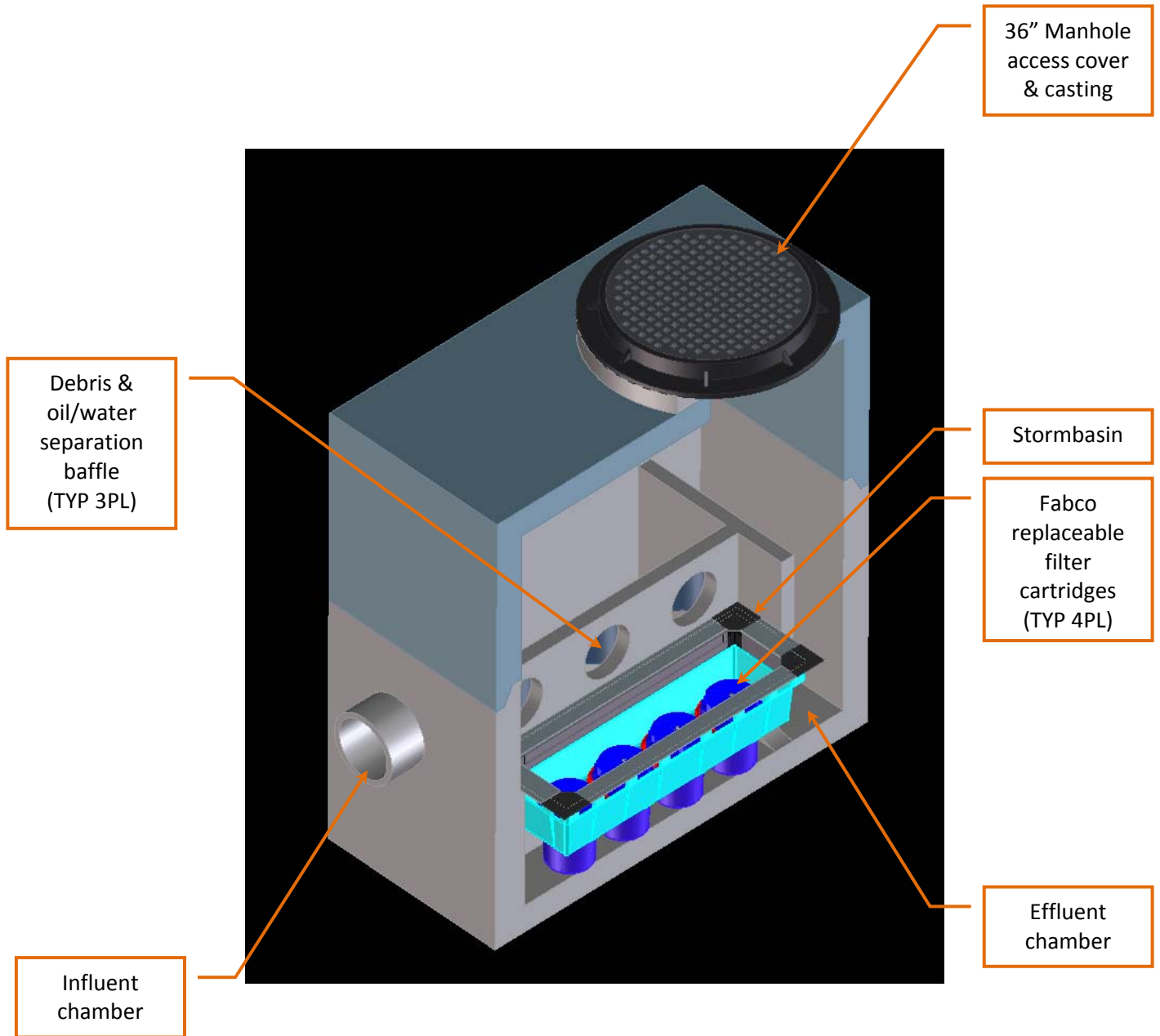

StormSafe-4C Detail (Figure 1)

<b><u>Inspection and Maintenance Log-Sheet</u></b>	
<b>StormSafe 4C – Stormwater Filtration Chamber</b>	
<b>Maintenance Company Information</b>	
Company Name:	
Onsite Technician:	
Contact Phone No:	
<b>StormSafe 4C - Vault Information</b>	
Date of Maintenance:	Fabco Vault P/N:
Vault Location:	
Water Depth (prior to maintenance):	<b><u>Comments</u></b>
Sediment Depth (prior to maintenance):	
Structural Damage:	
Maintenance Performed:	
Water level differential between chambers:	
Additional Work Required:	
Structural Repairs:	

## Maintenance Guidelines for Modular Wetland System - Linear

### Maintenance Summary

- Remove Trash from Screening Device – average maintenance interval is 6 to 12 months.
  - *(5 minute average service time).*
- Remove Sediment from Separation Chamber – average maintenance interval is 12 to 24 months.
  - *(10 minute average service time).*
- Replace Cartridge Filter Media – average maintenance interval 12 to 24 months.
  - *(10-15 minute per cartridge average service time).*
- Replace Drain Down Filter Media – average maintenance interval is 12 to 24 months.
  - *(5 minute average service time).*
- Trim Vegetation – average maintenance interval is 6 to 12 months.
  - *(Service time varies).*

### System Diagram

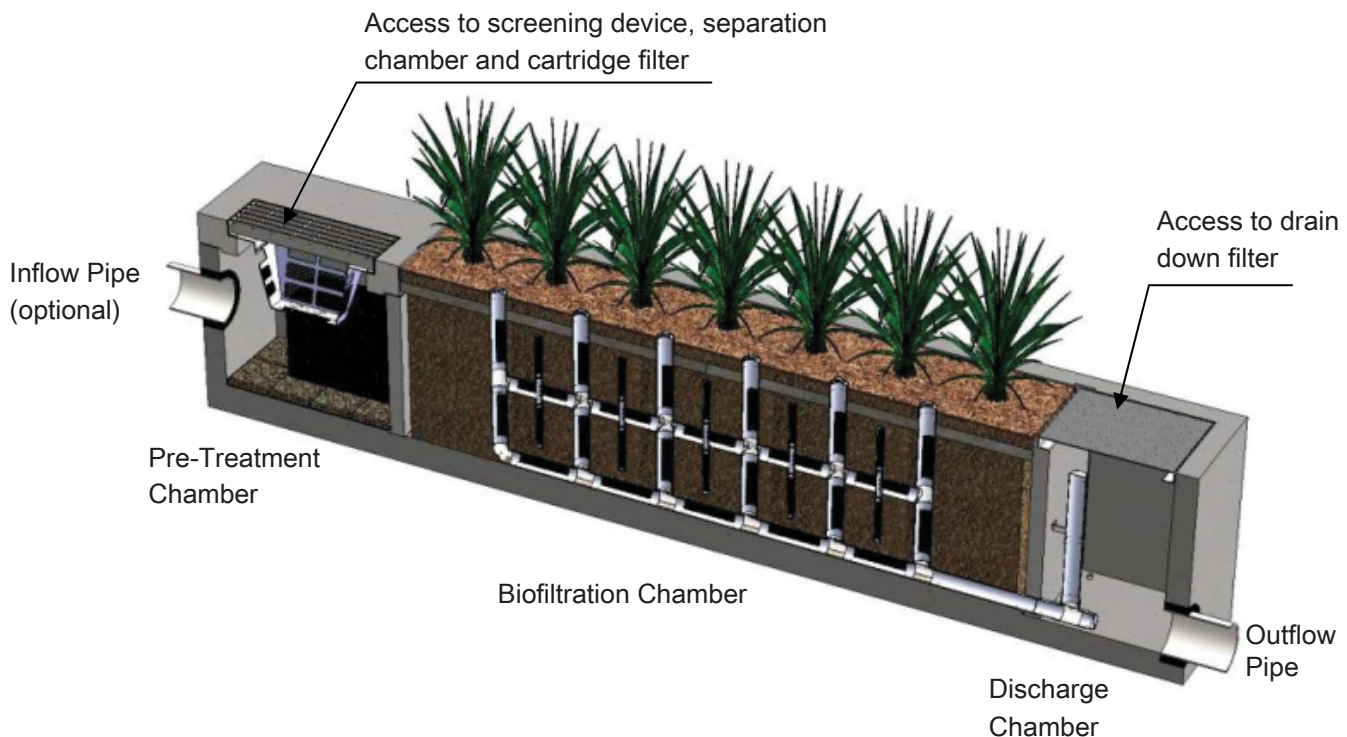

## Maintenance Procedures

### Screening Device

1. Remove grate or manhole cover to gain access to the screening device in the Pre-Treatment Chamber. Vault type units do not have screening device. Maintenance can be performed without entry.
2. Remove all pollutants collected by the screening device. Removal can be done manually or with the use of a vacuum truck. The hose of the vacuum truck will not damage the screening device.
3. Screening device can easily be removed from the Pre-Treatment Chamber to gain access to separation chamber and media filters below. Replace grate or manhole cover when completed.

### Separation Chamber

1. Perform maintenance procedures of screening device listed above before maintaining the separation chamber.
2. With a pressure washer spray down pollutants accumulated on walls and cartridge filters.
3. Vacuum out Separation Chamber and remove all accumulated pollutants. Replace screening device, grate or manhole cover when completed.

### Cartridge Filters

1. Perform maintenance procedures on screening device and separation chamber before maintaining cartridge filters.
2. Enter separation chamber.
3. Unscrew the two bolts holding the lid on each cartridge filter and remove lid.
4. Remove each of 4 to 8 media cages holding the media in place.
5. Spray down the cartridge filter to remove any accumulated pollutants.
6. Vacuum out old media and accumulated pollutants.
7. Reinstall media cages and fill with new media from manufacturer or outside supplier. Manufacturer will provide specification of media and sources to purchase.
8. Replace the lid and tighten down bolts. Replace screening device, grate or manhole cover when completed.

### Drain Down Filter

1. Remove hatch or manhole cover over discharge chamber and enter chamber.
2. Unlock and lift drain down filter housing and remove old media block. Replace with new media block. Lower drain down filter housing and lock into place.
3. Exit chamber and replace hatch or manhole cover.



## Maintenance Notes

1. Following maintenance and/or inspection, it is recommended the maintenance operator prepare a maintenance/inspection record. The record should include any maintenance activities performed, amount and description of debris collected, and condition of the system and its various filter mechanisms.
2. The owner should keep maintenance/inspection record(s) for a minimum of five years from the date of maintenance. These records should be made available to the governing municipality for inspection upon request at any time.
3. Transport all debris, trash, organics and sediments to approved facility for disposal in accordance with local and state requirements.
4. Entry into chambers may require confined space training based on state and local regulations.
5. No fertilizer shall be used in the Biofiltration Chamber.
6. Irrigation should be provided as recommended by manufacturer and/or landscape architect. Amount of irrigation required is dependent on plant species. Some plants may require irrigation.

## Maintenance Procedure Illustration

### Screening Device

The screening device is located directly under the manhole or grate over the Pre-Treatment Chamber. It's mounted directly underneath for easy access and cleaning. Device can be cleaned by hand or with a vacuum truck.



### Separation Chamber

The separation chamber is located directly beneath the screening device. It can be quickly cleaned using a vacuum truck or by hand. A pressure washer is useful to assist in the cleaning process.

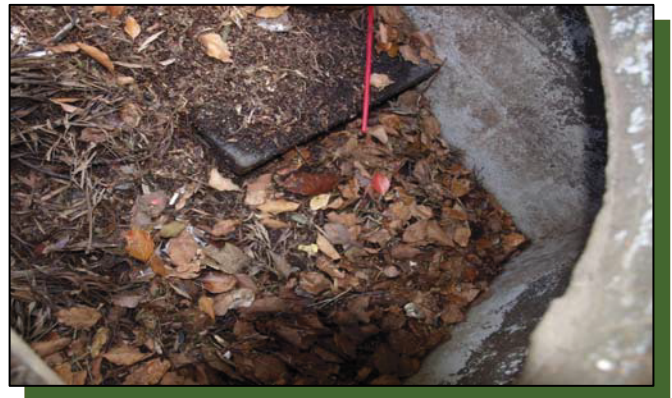

### Cartridge Filters

The cartridge filters are located in the Pre-Treatment chamber connected to the wall adjacent to the biofiltration chamber. The cartridges have removable tops to access the individual media filters. Once the cartridge is open media can be easily removed and replaced by hand or a vacuum truck.

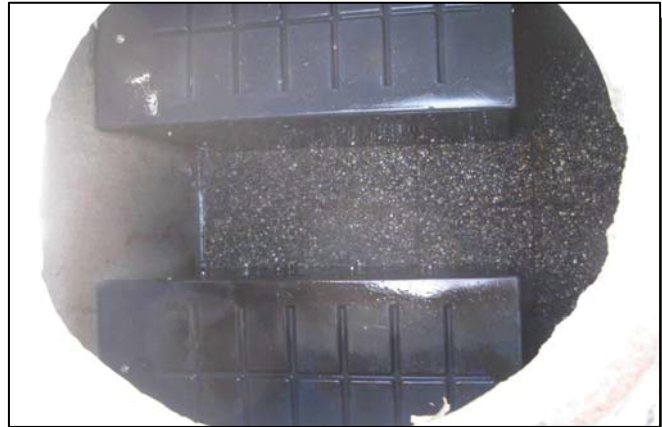

### Drain Down Filter

The drain down filter is located in the Discharge Chamber. The drain filter unlocks from the wall mount and hinges up. Remove filter block and replace with new block.



### Trim Vegetation

Vegetation should be maintained in the same manner as surrounding vegetation and trimmed as needed. No fertilizer shall be used on the plants. Irrigation per the recommendation of the manufacturer and or landscape architect. Different types of vegetation requires different amounts of irrigation.





## Inspection Form



**Modular Wetland System, Inc.**

**P. 760.433-7640**

**F. 760-433-3176**

**E. [Info@modularwetlands.com](mailto:Info@modularwetlands.com)**

**[www.modularwetlands.com](http://www.modularwetlands.com)**



# Inspection Report Modular Wetlands System



Project Name \_\_\_\_\_

Project Address \_\_\_\_\_ (city) (Zip Code)

Owner / Management Company \_\_\_\_\_

Contact \_\_\_\_\_

Phone ( ) -

Inspector Name \_\_\_\_\_

Date \_\_\_\_ / \_\_\_\_ / \_\_\_\_

Time \_\_\_\_\_ AM / PM

Type of Inspection  Routine  Follow Up  Complaint

Storm

Storm Event in Last 72-hours?  No  Yes

Weather Condition \_\_\_\_\_

Additional Notes \_\_\_\_\_

For Office Use Only

(Reviewed By)

(Date)  
Office personnel to complete section to the left.

## Inspection Checklist

Modular Wetland System Type (Curb, Grate or UG Vault): \_\_\_\_\_ Size (22', 14' or etc.): \_\_\_\_\_

Structural Integrity:	Yes	No	Comments
Damage to pre-treatment access cover (manhole cover/grate) or cannot be opened using normal lifting pressure?			
Damage to discharge chamber access cover (manhole cover/grate) or cannot be opened using normal lifting pressure?			
Does the MWS unit show signs of structural deterioration (cracks in the wall, damage to frame)?			
Is the inlet/outlet pipe or drain down pipe damaged or otherwise not functioning properly?			
<b>Working Condition:</b>			
Is there evidence of illicit discharge or excessive oil, grease, or other automobile fluids entering and clogging the unit?			
Is there standing water in inappropriate areas after a dry period?			
Is the filter insert (if applicable) at capacity and/or is there an accumulation of debris/trash on the shelf system?			
Does the depth of sediment/trash/debris suggest a blockage of the inflow pipe, bypass or cartridge filter? If yes, specify which one in the comments section. Note depth of accumulation in in pre-treatment chamber.			Depth:
Does the cartridge filter media need replacement in pre-treatment chamber and/or discharge chamber?			Chamber:
Any signs of improper functioning in the discharge chamber? Note issues in comments section.			
<b>Other Inspection Items:</b>			
Is there an accumulation of sediment/trash/debris in the wetland media (if applicable)?			
Is it evident that the plants are alive and healthy (if applicable)? Please note Plant Information below.			
Is there a septic or foul odor coming from inside the system?			

Waste:	Yes	No
Sediment / Silt / Clay		
Trash / Bags / Bottles		
Green Waste / Leaves / Foliage		

Recommended Maintenance	
No Cleaning Needed	
Schedule Maintenance as Planned	
Needs Immediate Maintenance	

Plant Information	
Damage to Plants	
Plant Replacement	
Plant Trimming	

Additional Notes: \_\_\_\_\_

## Maintenance Report



**Modular Wetland System, Inc.**

**P. 760.433-7640**

**F. 760-433-3176**

**E. [Info@modularwetlands.com](mailto:Info@modularwetlands.com)**

**[www.modularwetlands.com](http://www.modularwetlands.com)**



# Cleaning and Maintenance Report Modular Wetlands System



Project Name \_\_\_\_\_

Project Address \_\_\_\_\_ (city) (Zip Code)

Owner / Management Company \_\_\_\_\_

Contact \_\_\_\_\_ Phone ( ) -

Inspector Name \_\_\_\_\_ Date \_\_\_\_ / \_\_\_\_ / \_\_\_\_ Time \_\_\_\_ AM / PM

Type of Inspection  Routine  Follow Up  Complaint  Storm Storm Event in Last 72-hours?  No  Yes

Weather Condition \_\_\_\_\_ Additional Notes \_\_\_\_\_

For Office Use Only

---

(Reviewed By)

---

(Date)  
Office personnel to complete section to the left.

Site Map #	GPS Coordinates of Insert	Manufacturer / Description / Sizing	Trash Accumulation	Foliage Accumulation	Sediment Accumulation	Total Debris Accumulation	Condition of Media 25/50/75/100 (will be changed @ 75%)	Operational Per Manufactures' Specifications (If not, why?)
	Lat: Long:	MWS Catch Basins						
		MWS Sedimentation Basin						
		Media Filter Condition						
		Plant Condition						
		Drain Down Media Condition						
		Discharge Chamber Condition						
		Drain Down Pipe Condition						
		Inlet and Outlet Pipe Condition						

Comments:

---



---

# **Attachment C: Site Plans**

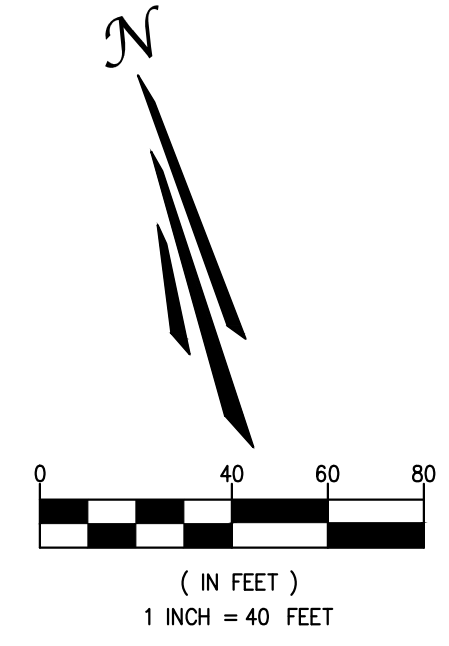
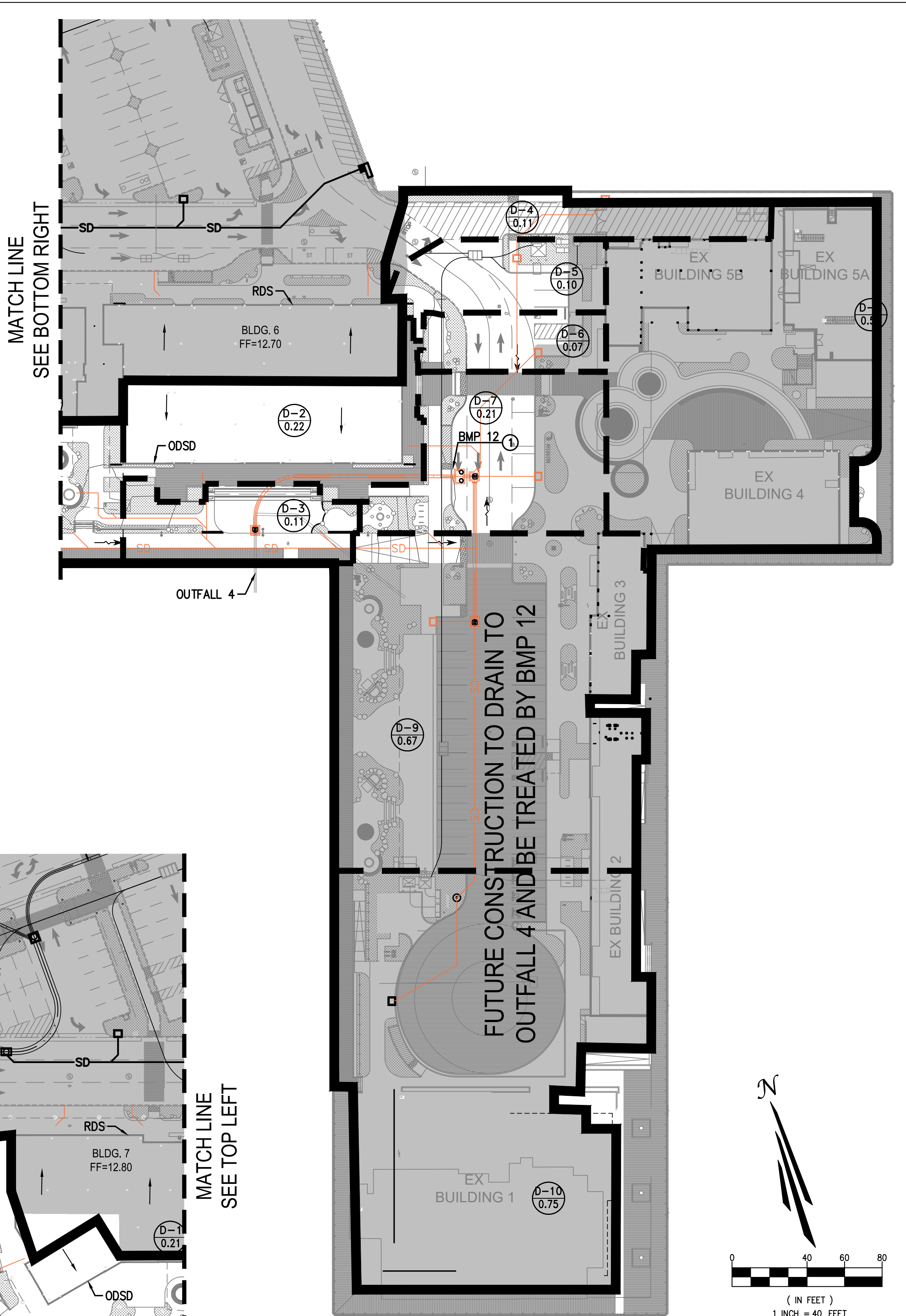
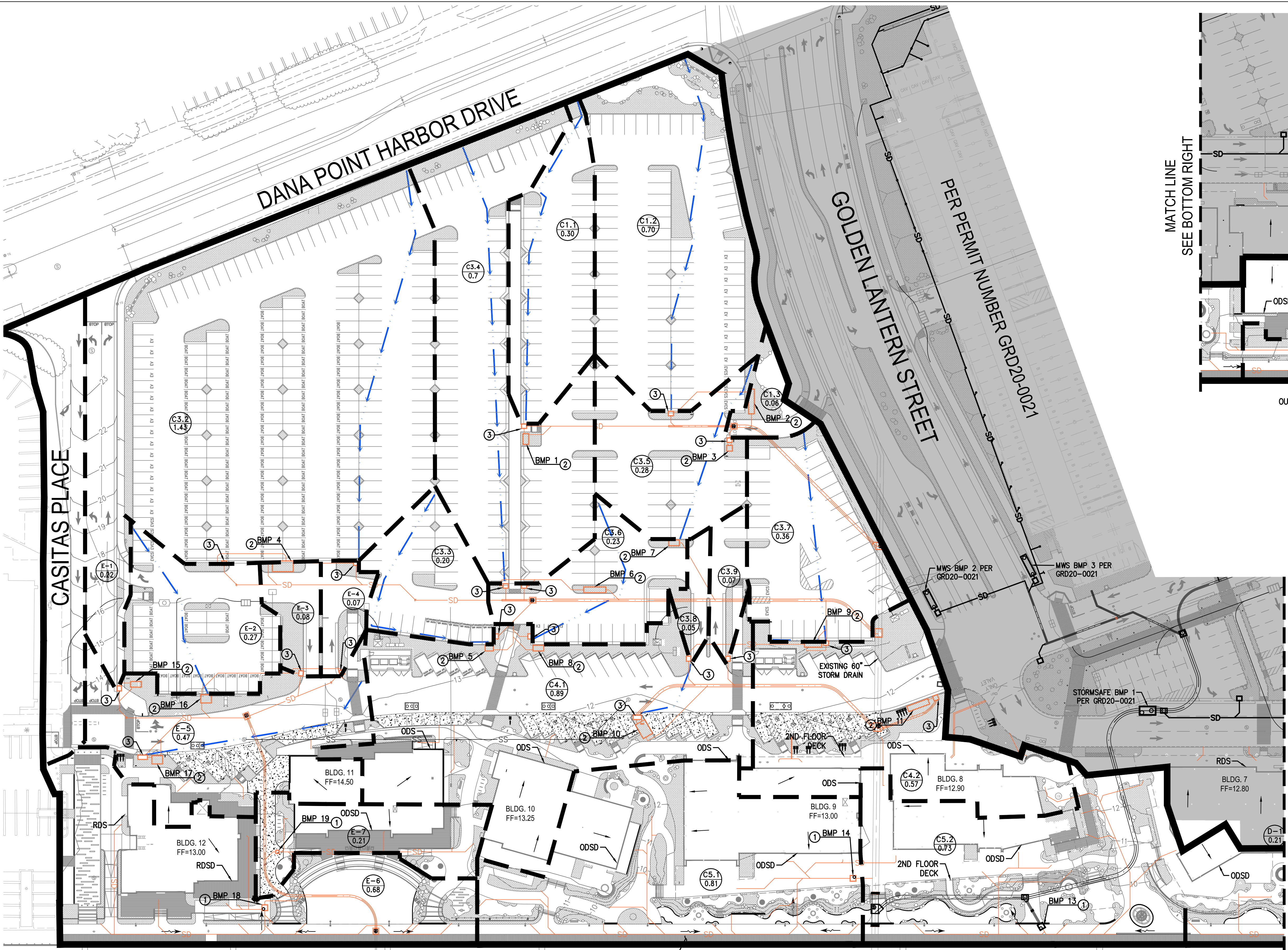

**LEGEND**

	DRAINAGE AREA BOUNDARY		ROOF SURFACE FLOW
	DRAINAGE SUB-AREA BOUNDARY		STORM DRAIN DIRECTION OF FLOW
	EXISTING STORM DRAIN LINE		ROOF DRAINS TO SURFACE
	PROPOSED STORM DRAIN LINE		ROOF DRAINS CONNECT TO STORM DRAIN
	SUBAREA ID		OVER DRAINS TO SURFACE
	SUBAREA ACREAGE		OVER DRAINS CONNECT TO STORM DRAIN
	LANDSCAPE AREA		

**WQMP NOTES**

- ① INSTALL JENSEN STORMSAFE FILTRATION VAULT PER MANUFACTURER SPECIFICATIONS AND RECOMMENDATIONS.
- ② INSTALL MODULAR WETLAND SYSTEM (MWS) PER MANUFACTURER SPECIFICATIONS AND RECOMMENDATIONS, SIZE AS SHOWN ON TABLE ON SHEET 2.
- ③ CATCH BASINS WITH STORM DRAIN INLET MARKING AND BIOCLEAN DIVERT SYSTEM.

NOTE: SEE SHEETS 3 AND 4 FOR DETAILS.

**NOTE**  
SEE SHEET 2 FOR DRAINAGE MANAGEMENT AREA SUMMARY

NO.	DATE	REVISIONS	ENGR.	APPROV.	DATE
7					
6					
5					
4					
3					
2					
1					

PREPARED UNDER THE SUPERVISION OF:

**TAIT**  
Since 1964

701 N. Parkcenter Drive  
Santa Ana, CA 92705  
p: 714/560/8200 f: 714/560/8211  
www.tait.com

Los Angeles Sacramento San Francisco Dallas Phoenix  
Ontario San Diego Boise Denver Portland

DESIGN ENGINEER R.C.E. No. DATE 9/12/22

DRAWN BY:	DATE
DESIGNED BY:	DATE
CHECKED BY:	DATE
RECOMMENDED BY:	DATE

**DANA POINT HARBOR REVITALIZATION**  
DANA POINT HARBOR PARTNERS, LLC

**BWP** BURNHAM I WARD PROPERTIES **R.D. OLSON** DEVELOPMENT **BELLWETHER** FINANCIAL GROUP

**BUILDINGS 6-12 AND SURFACE PARKING LOT PRECISE GRADING PLANS**

COMMERCIAL CORE WQMP SITE MAP

SHT 1 OF 4

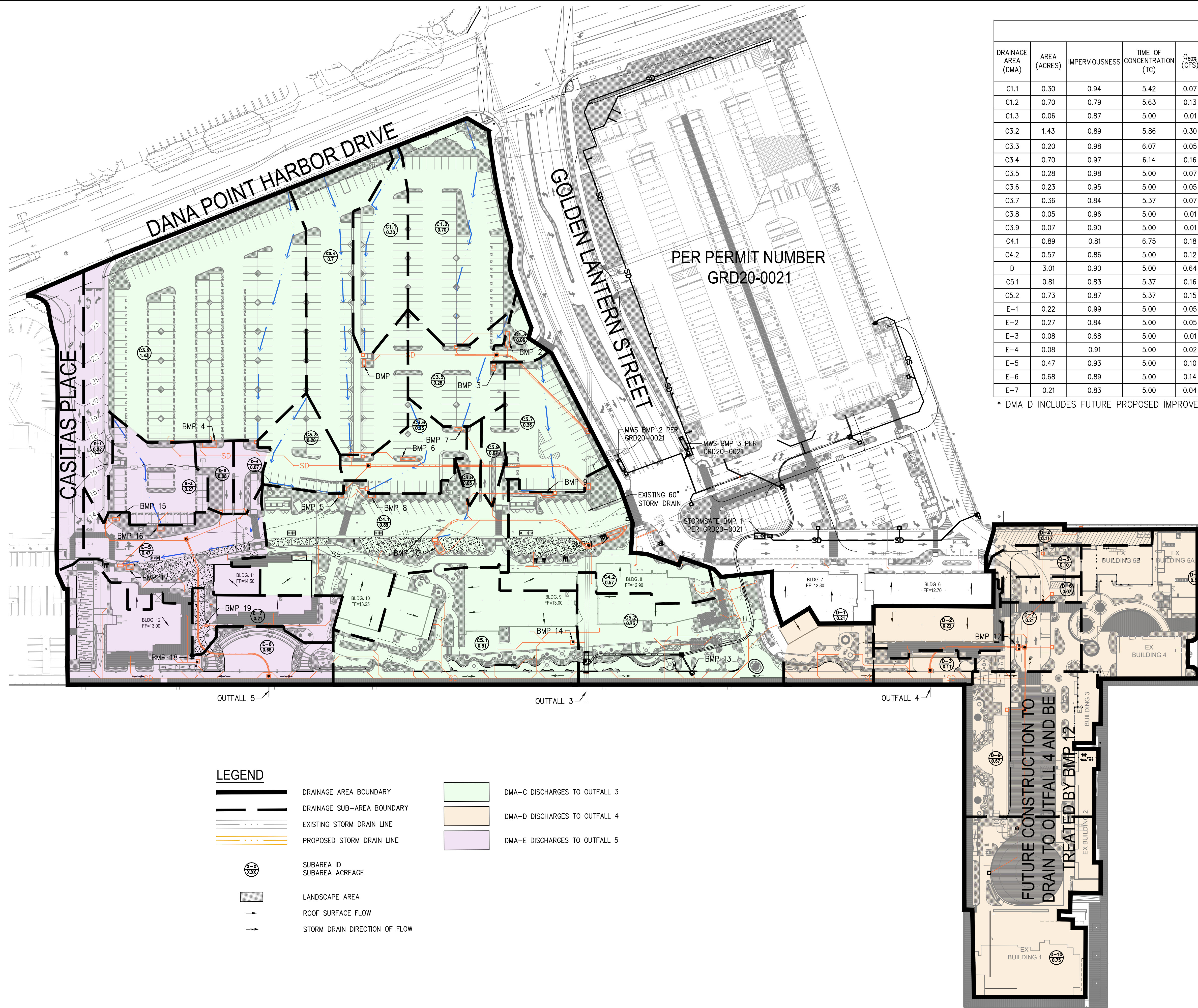

PER PERMIT NUMBER  
GRD20-0021

DRAINAGE MANAGEMENT AREA SUMMARY												
DRAINAGE AREA (DMA)	AREA (ACRES)	IMPERVIOUSNESS	TIME OF CONCENTRATION (TC)	Q <sub>0.05</sub> (CFS)	Q <sub>0.025</sub> (CFS)	BEST MANAGEMENT PRACTICE (BMP)	BMP TYPE	BMP MODEL	BMP SIZING	FLOW TREATMENT CAPACITY (CFS)	No. OF INLETS W/ DIVERT	OUTFALL LOCATION
C1.1	0.30	0.94	5.42	0.07	0.1	1	MWS	L-4-8-V	5' x 9'	0.1	YES (1)	OUTFALL 3
C1.2	0.70	0.79	5.63	0.13	0.202	2	MWS	L-4-19-V	5' x 20'	0.202	YES (1)	OUTFALL 3
C1.3	0.06	0.87	5.00	0.01	0.019	3	MWS	L-4-4-V	5' x 5'	0.019	YES (1)	OUTFALL 3
C3.2	1.43	0.89	5.86	0.30	0.457	4	MWS	L-8-16-V HC=3.6	9' x 17'	0.462	YES (2)	OUTFALL 3
C3.3	0.20	0.98	6.07	0.05	0.069	5	MWS	L-4-6-V	4' x 6'	0.069	YES (1)	OUTFALL 3
C3.4	0.70	0.97	6.14	0.16	0.239	6	MWS	L-4-17-V	5' x 18'	0.239	YES (1)	OUTFALL 3
C3.5	0.28	0.98	5.00	0.07	0.104	7	MWS	L-4-8-C	5' x 9'	0.105	NO	OUTFALL 3
C3.6	0.23	0.95	5.00	0.05	0.077	8	MWS	L-4-8-V	5' x 9'	0.078	YES (1)	OUTFALL 3
C3.7	0.36	0.84	5.37	0.07	0.110						YES (1)	
C3.8	0.05	0.96	5.00	0.01	0.017	9	MWS	L-4-13-V	5' x 14'	0.148	YES (1)	OUTFALL 3
C3.9	0.07	0.90	5.00	0.01	0.022						YES (1)	
C4.1	0.89	0.81	6.75	0.18	0.264	10	MWS	L-8-12-V	9' x 13'	0.265	YES (1)	OUTFALL 3
C4.2	0.57	0.86	5.00	0.12	0.177	11	MWS	L-4-17-V	5' x 18'	0.177	YES (1)	OUTFALL 3
D	3.01	0.90	5.00	0.64	0.967	12	STORMSAFE	STORMFILTER	10 PACK	2.56	-	OUTFALL 4
C5.1	0.81	0.83	5.37	0.16	0.245	14	STORMSAFE	STORMFILTER	3 PACK	0.768	-	OUTFALL 3
C5.2	0.73	0.87	5.37	0.15	0.228	13	STORMSAFE	STORMFILTER	3 PACK	0.768	-	OUTFALL 3
E-1	0.22	0.99	5.00	0.05	0.077	15	MWS	L-4-8-V	5' x 9'	0.078	YES (1)	OUTFALL 5
E-2	0.27	0.84	5.00	0.05	0.082						YES (1)	
E-3	0.08	0.68	5.00	0.01	0.021	16	MWS	L-6-8-C W/ 2 PIPE INLETS	7' x 9'	0.129	YES (1)	OUTFALL 5
E-4	0.08	0.91	5.00	0.02	0.026						-	
E-5	0.47	0.93	5.00	0.10	0.155	17	MWS	L-6-8-C	7' x 9'	0.155	YES (1)	OUTFALL 5
E-6	0.68	0.89	5.00	0.14	0.217	18	STORMSAFE	STORMFILTER	3 PACK	0.768	-	OUTFALL 5
E-7	0.21	0.83	5.00	0.04	0.063	19	STORMSAFE	STORMFILTER	1 PACK	0.256	-	OUTFALL 5

\* DMA D INCLUDES FUTURE PROPOSED IMPROVEMENTS FOR THE DESIGN OF STORMSAFE UNIT BMP 12.

NOTES:

- PROJECT IS EXEMPT FROM HYDROLOGIC CONDITION OF CONCERN (HCO). SEE SECTION 3.5 IN WQMP REPORT.
- DESIGN CAPTURE VOLUME (DCV) IS NOT APPLICABLE. FLOW-BASED DESIGN USED.

LEGEND

- DRAINAGE AREA BOUNDARY
- DRAINAGE SUB-AREA BOUNDARY
- EXISTING STORM DRAIN LINE
- PROPOSED STORM DRAIN LINE
- SUBAREA ID  
SUBAREA ACREAGE
- LANDSCAPE AREA
- ROOF SURFACE FLOW
- STORM DRAIN DIRECTION OF FLOW
- DMA-C DISCHARGES TO OUTFALL 3
- DMA-D DISCHARGES TO OUTFALL 4
- DMA-E DISCHARGES TO OUTFALL 5

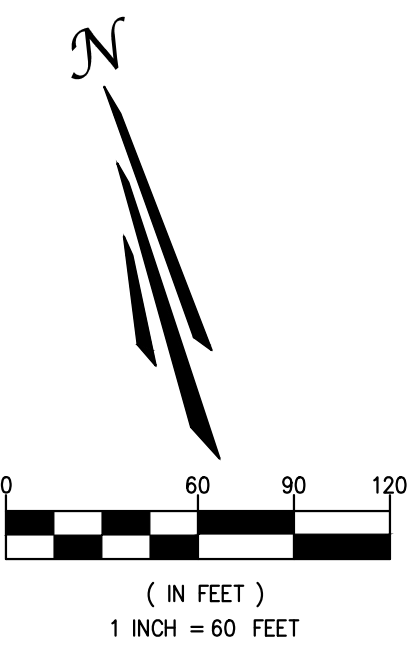

NO.	DATE	REVISIONS	ENGR.	APPROV.	DATE
7					
6					
5					
4					
3					
2					
1					

PREPARED UNDER THE SUPERVISION OF:

**TAIT**  
Since 1964

701 N. Parkcenter Drive  
Santa Ana, CA 92705  
p: 714/560/8200 f: 714/560/8211  
www.tait.com

Los Angeles Sacramento San Francisco Dallas Phoenix  
Ontario San Diego Boise Denver Portland

DESIGN ENGINEER R.C.E. No. 9/12/22 DATE

DRAWN BY:	DATE:
DESIGNED BY:	DATE:
CHECKED BY:	DATE:
RECOMMENDED BY:	DATE:

DANA POINT HARBOR REVITALIZATION

DANA POINT HARBOR PARTNERS, LLC



BUILDINGS 6-12 AND SURFACE  
PARKING LOT  
PRECISE GRADING PLANS

COMMERCIAL CORE DMA EXHIBIT



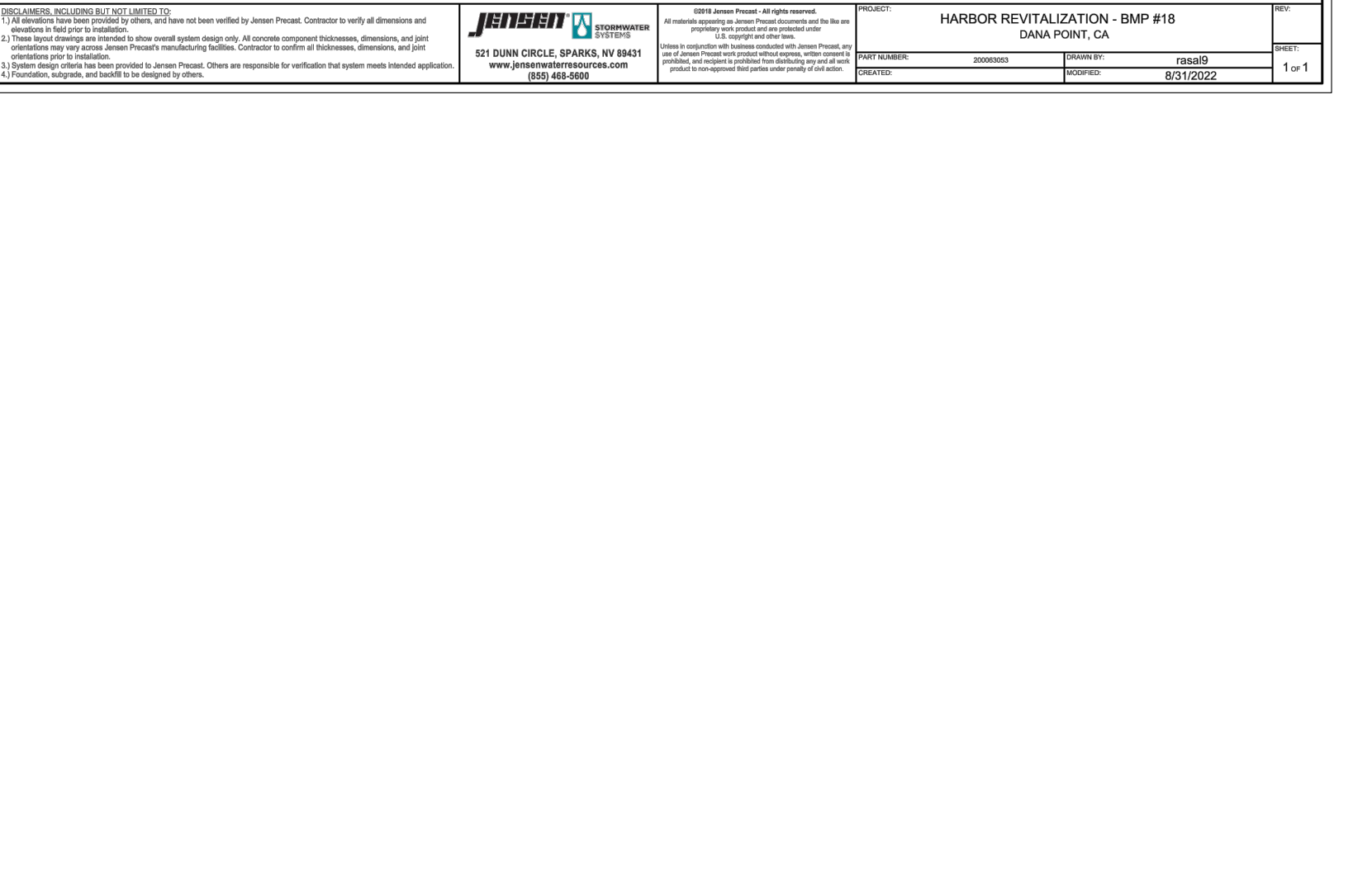
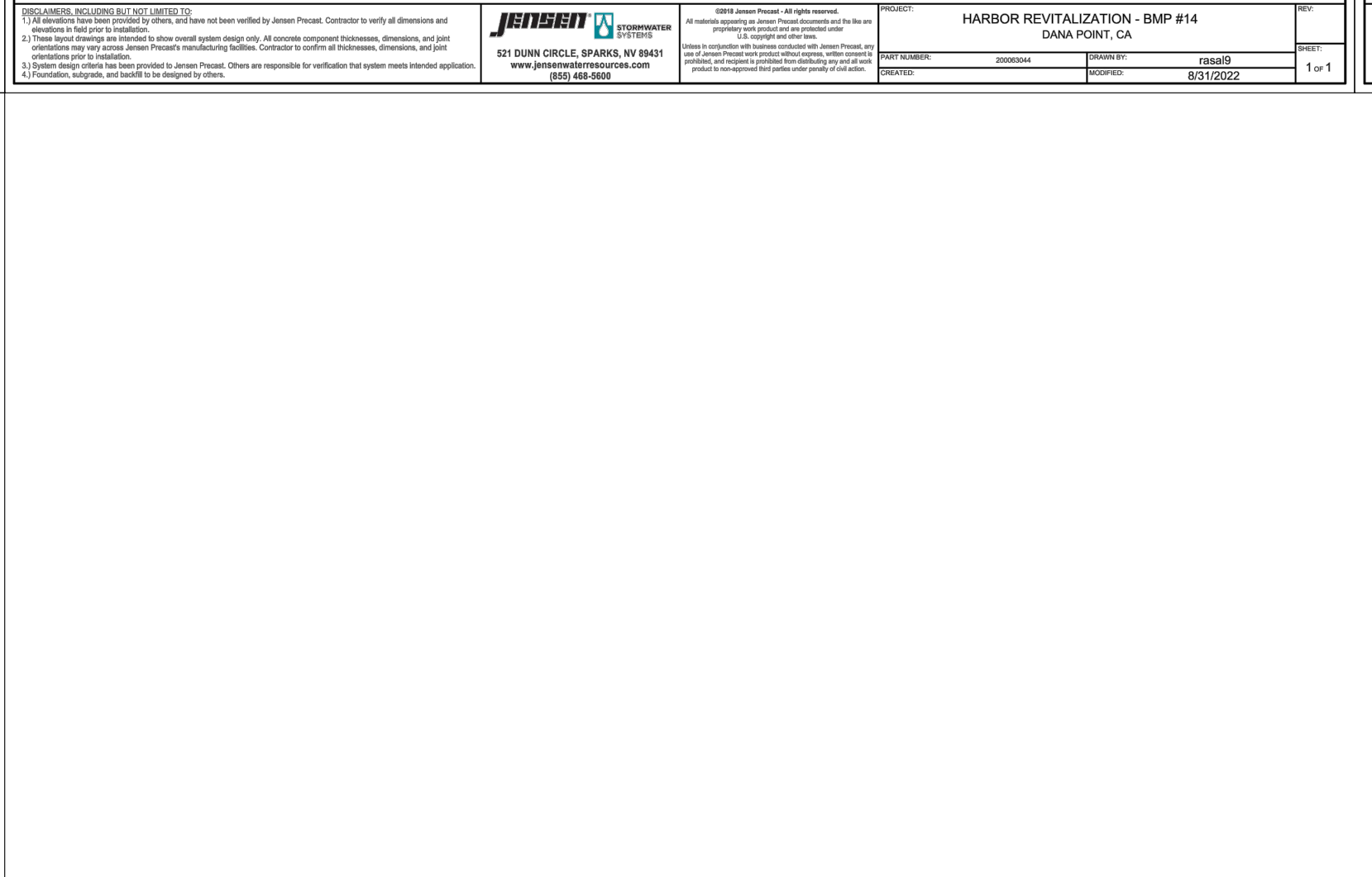
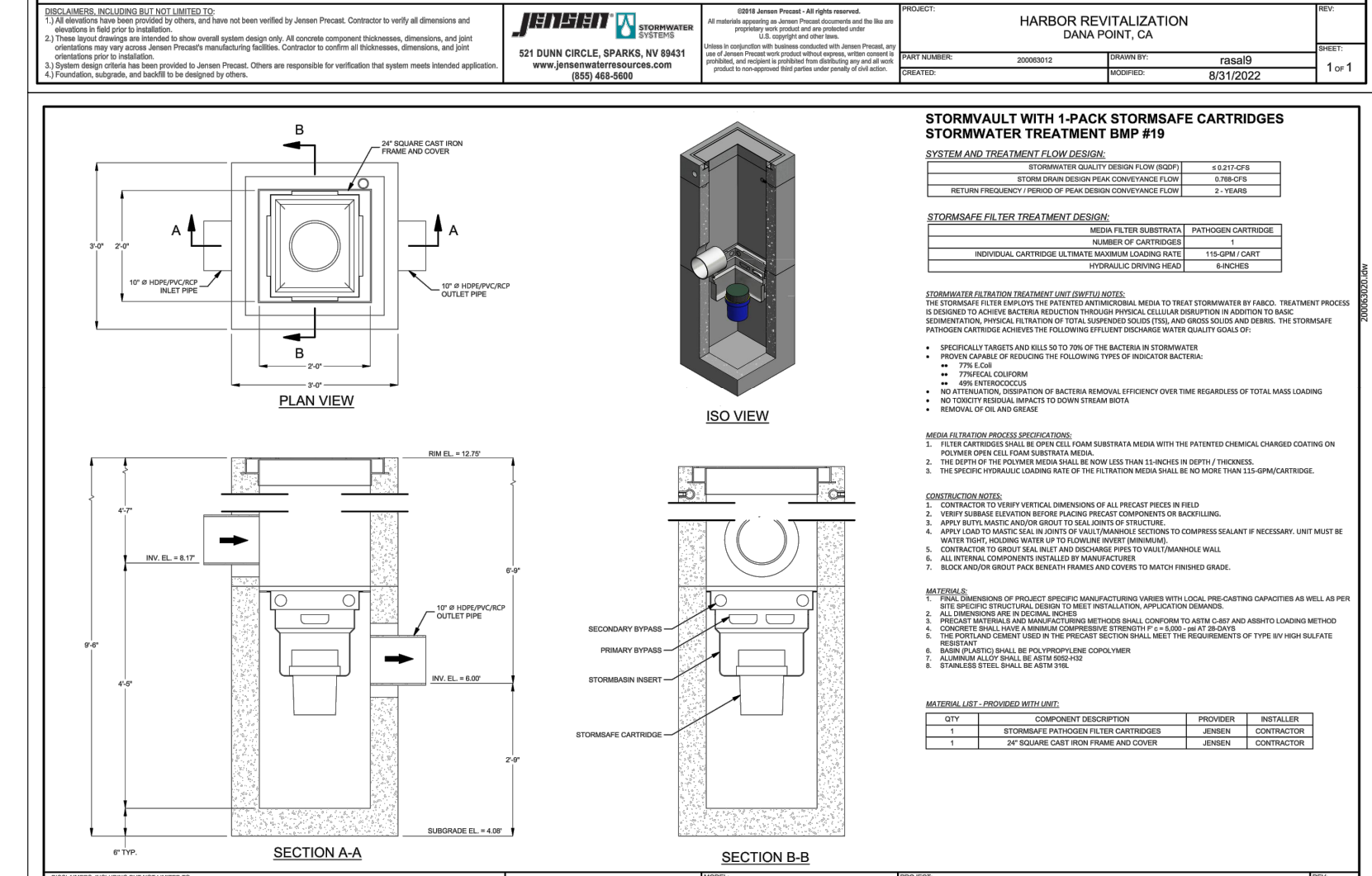
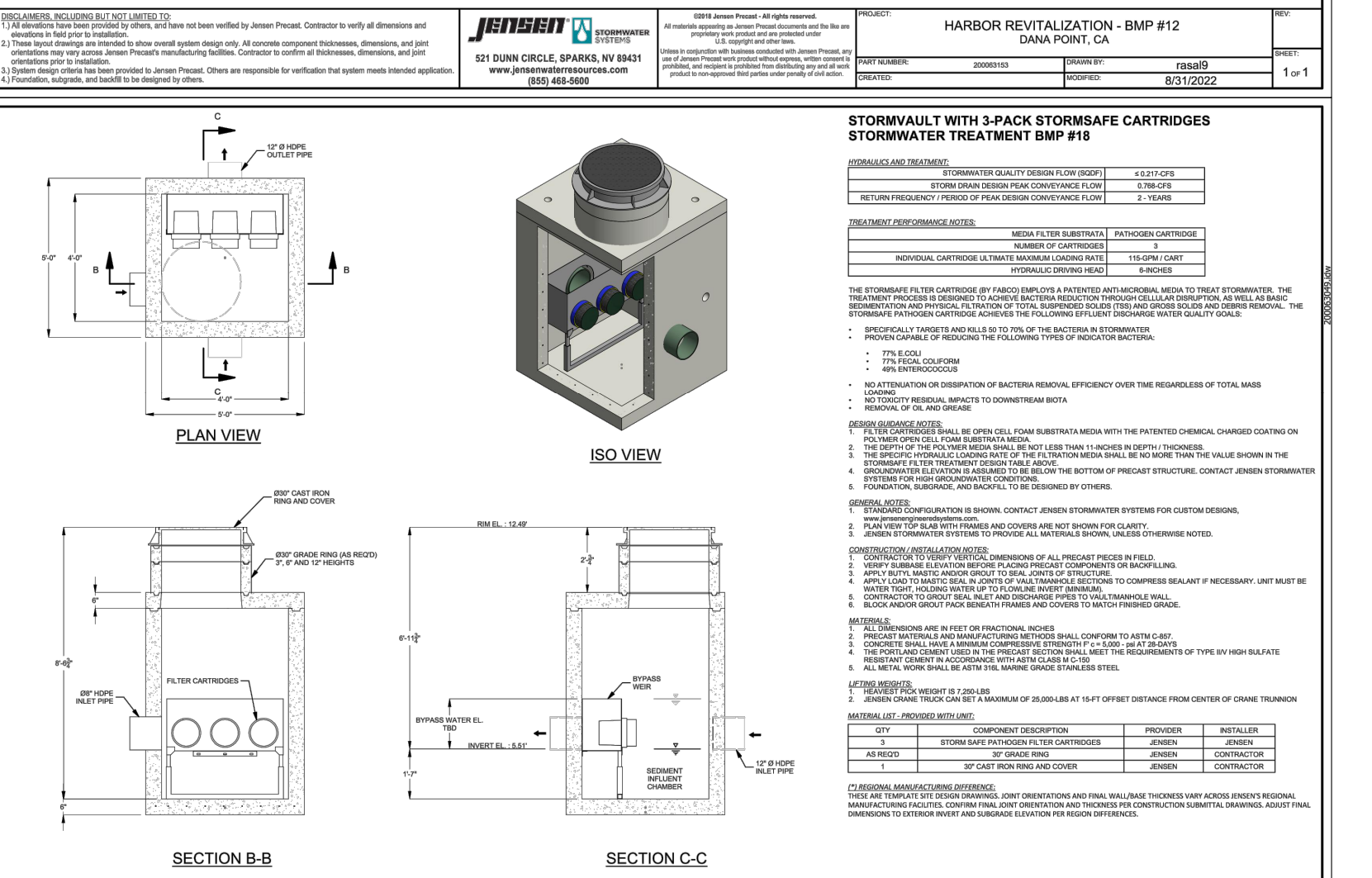
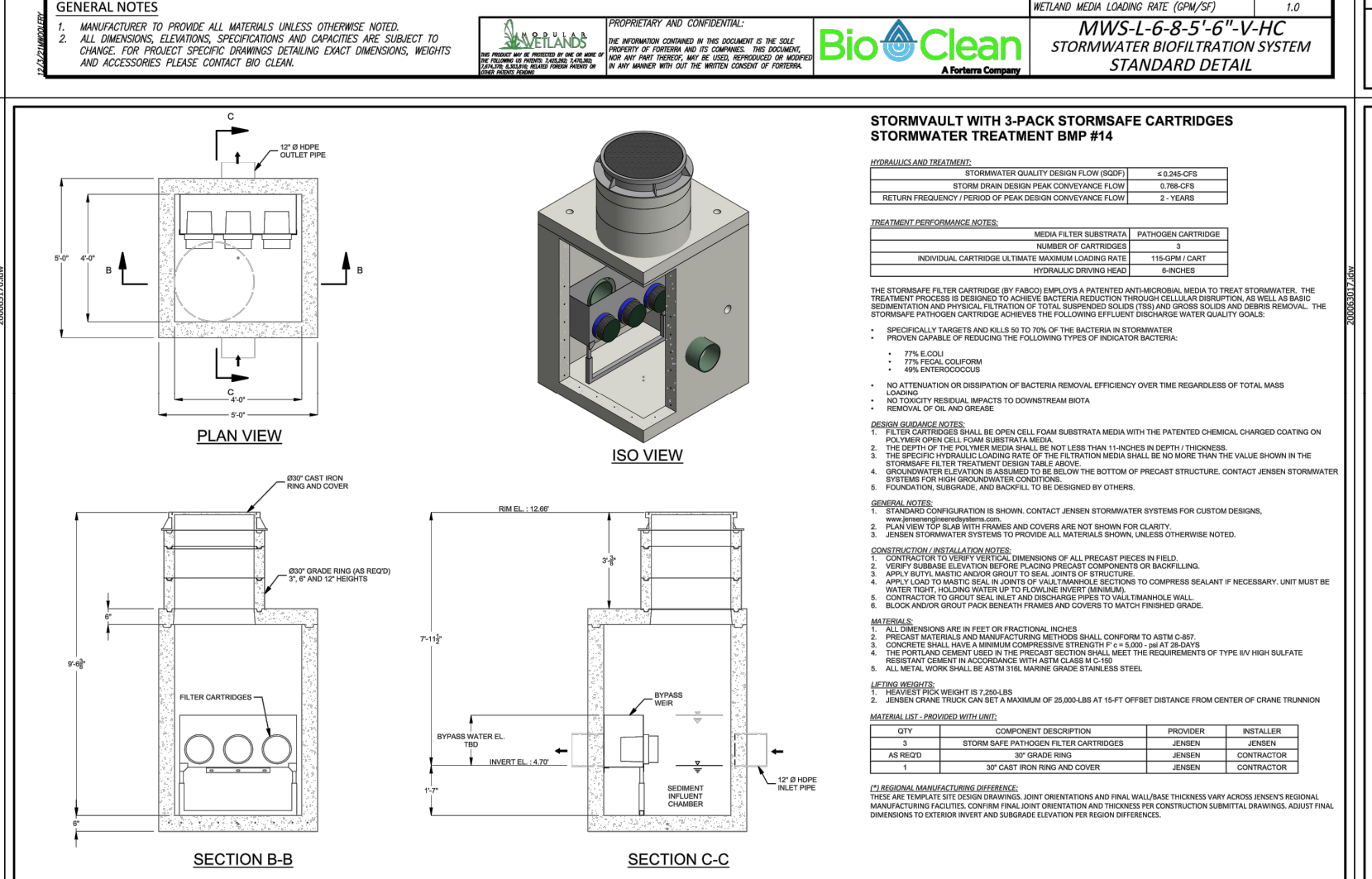
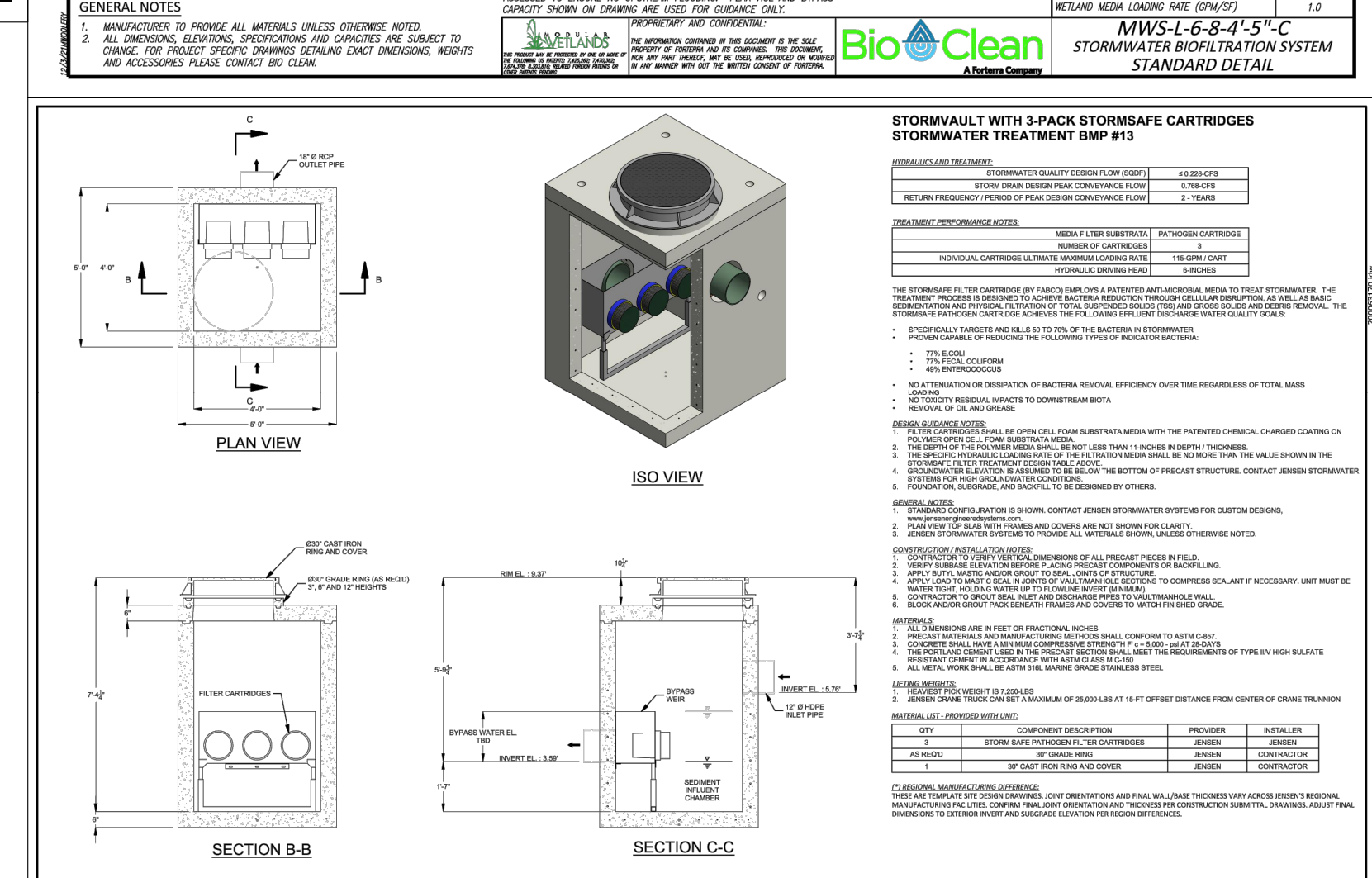
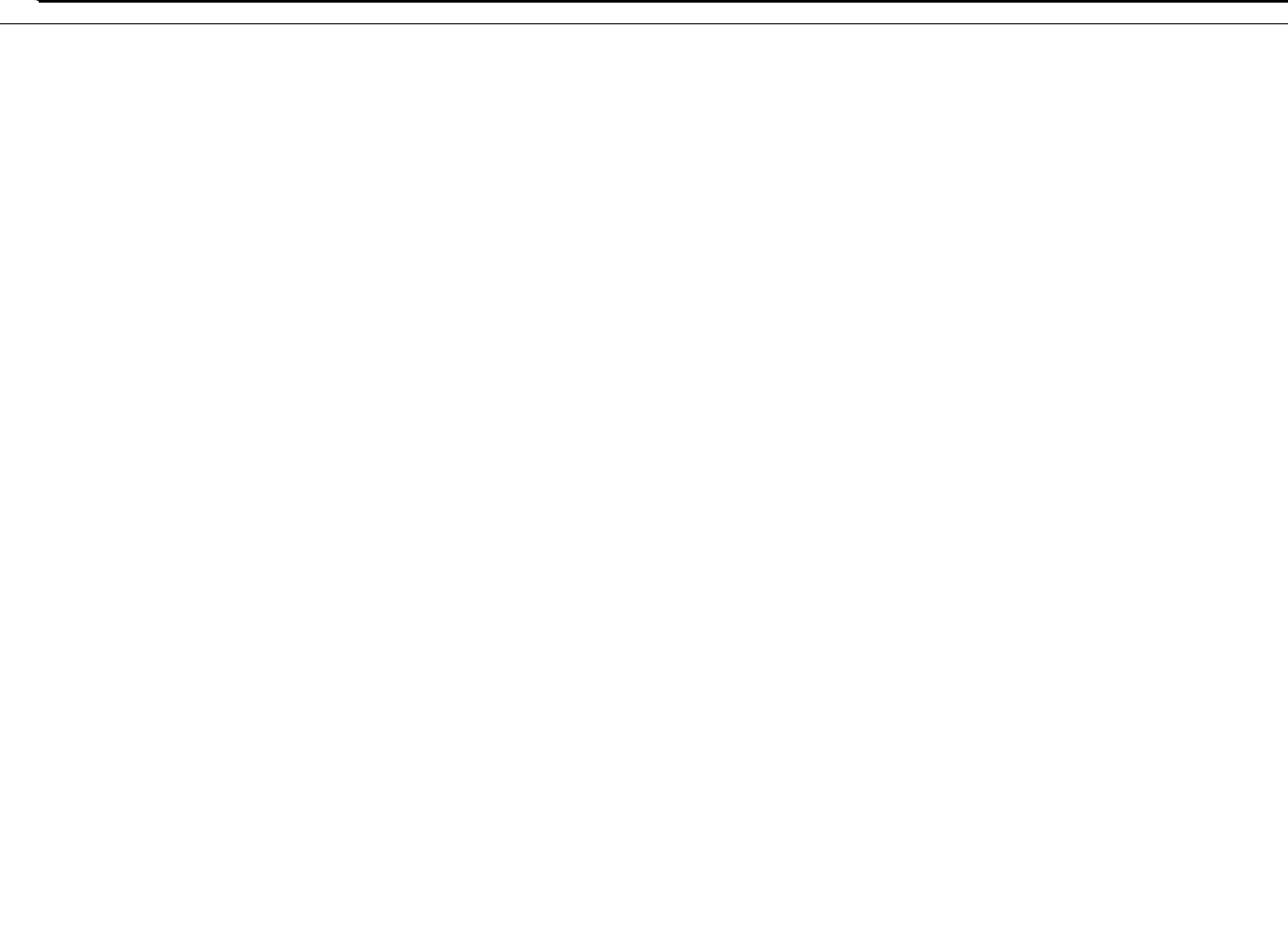
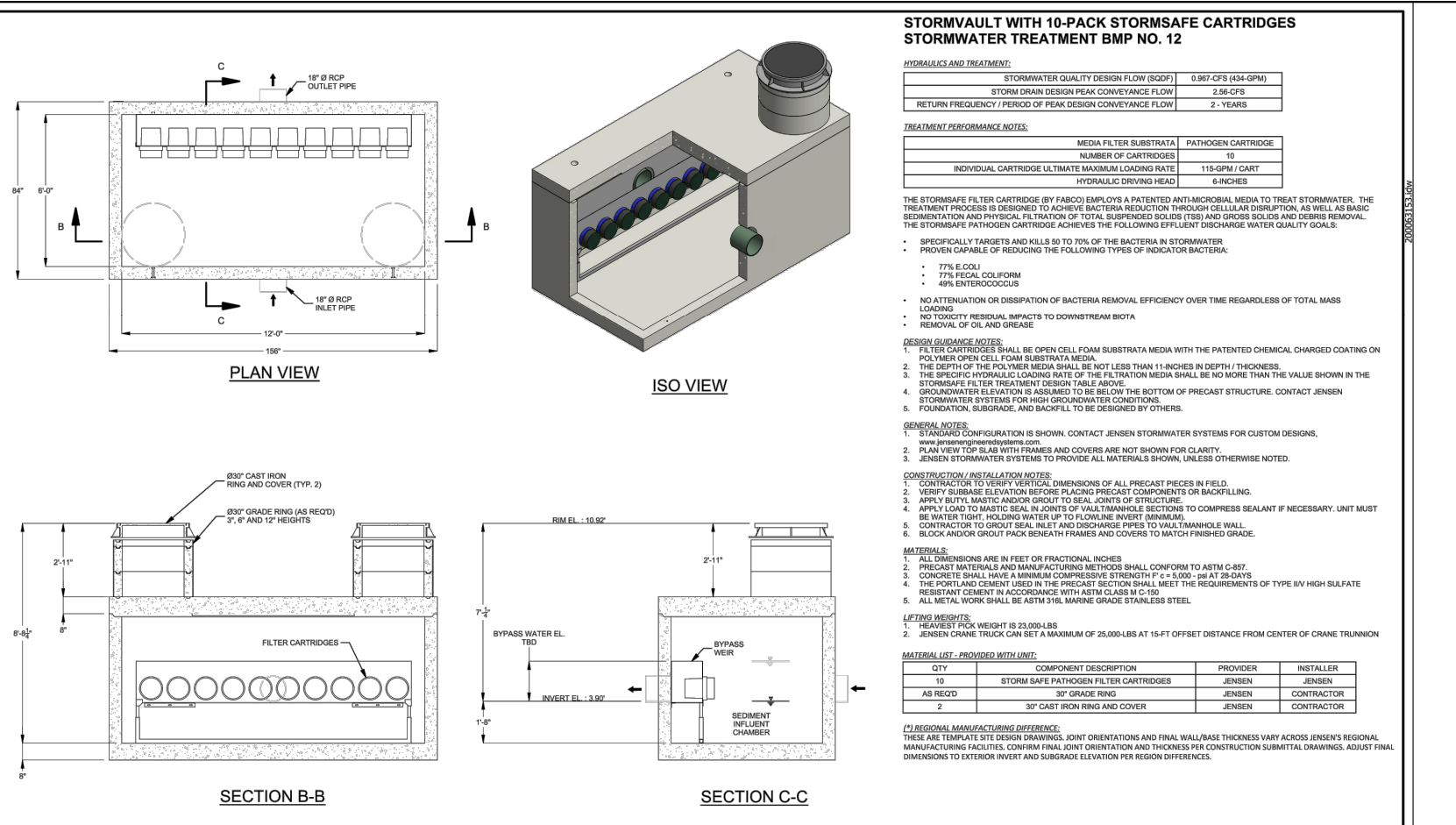
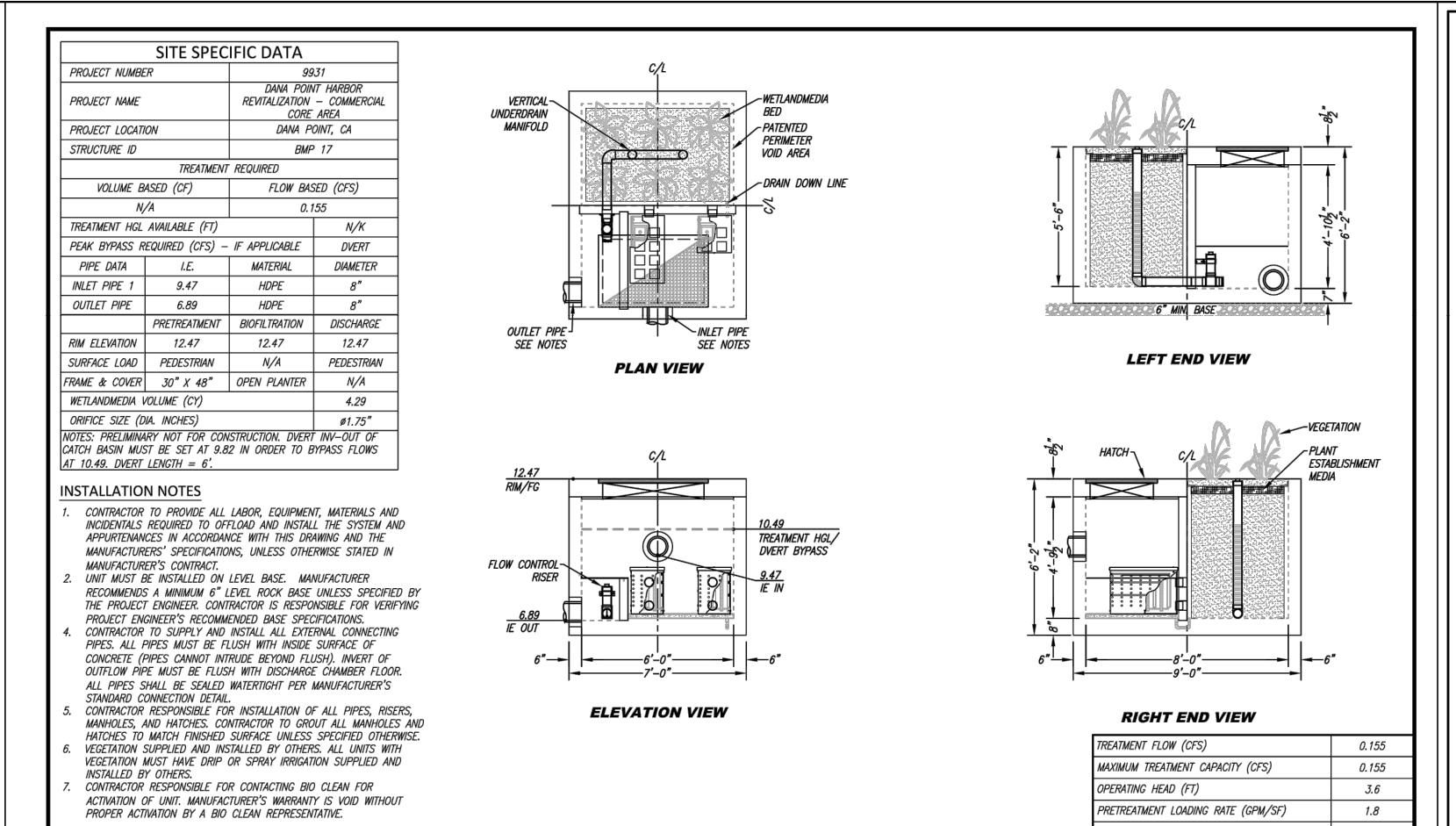
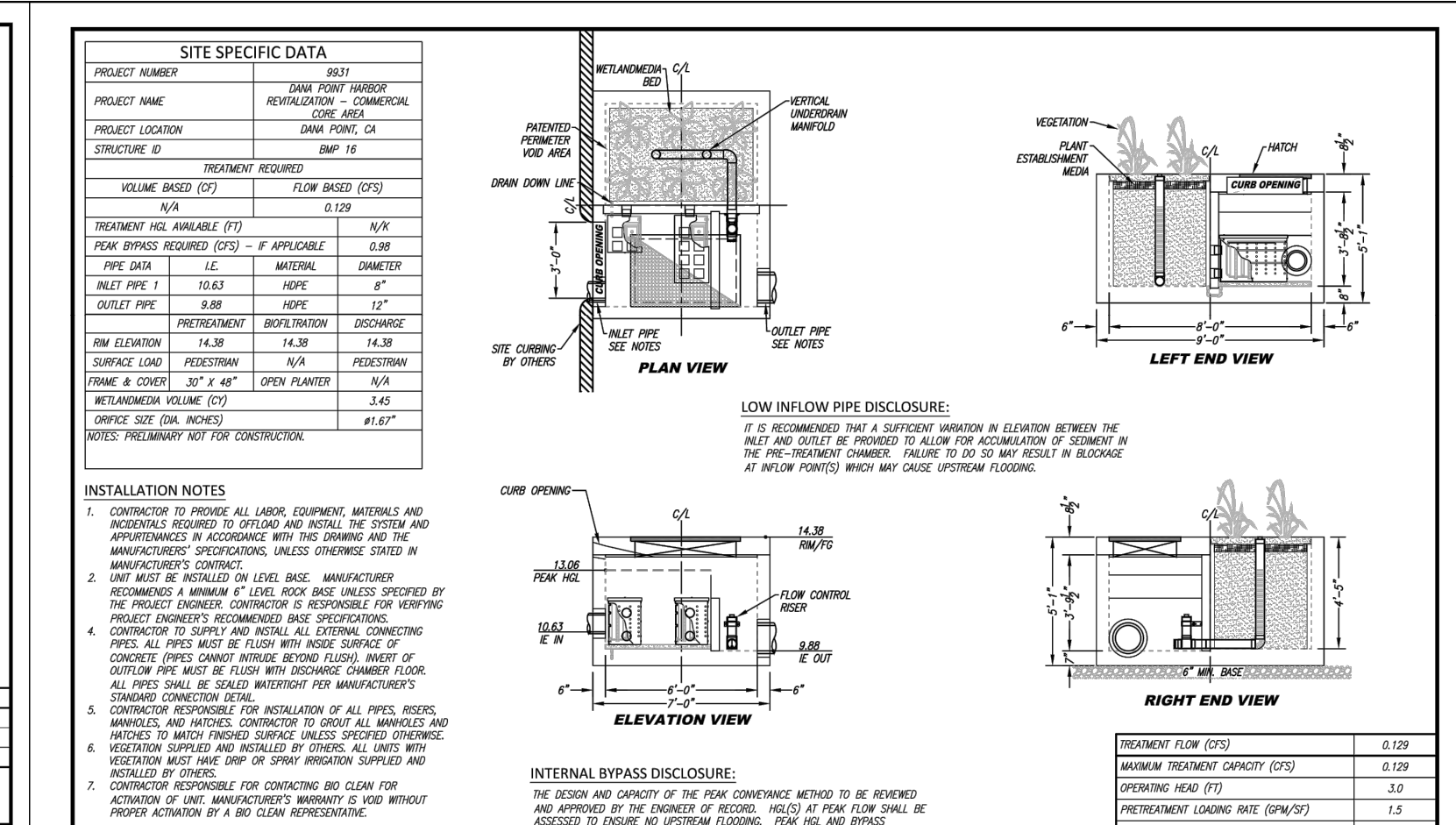
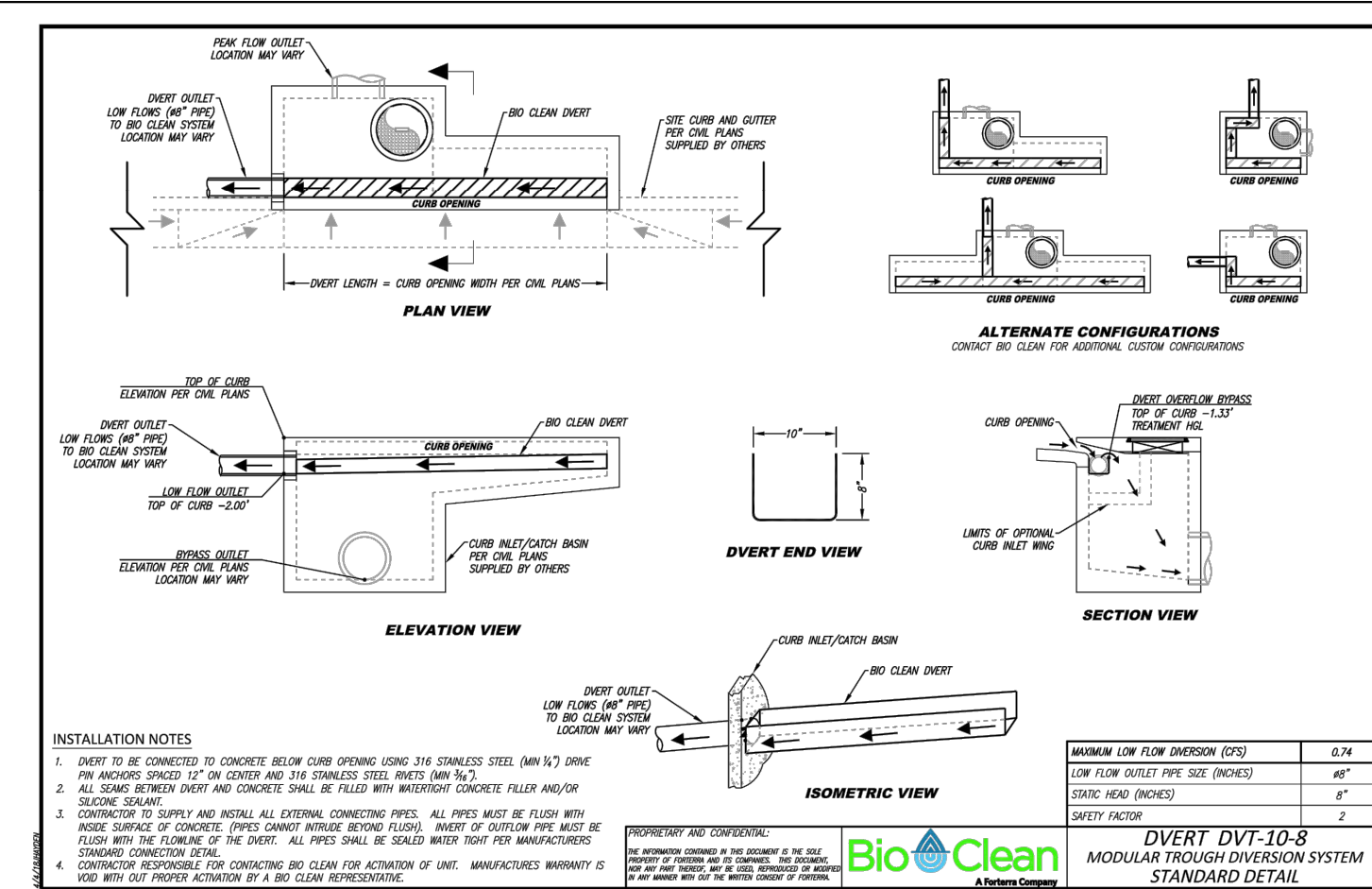

NO.	DATE	REVISIONS	ENGR.	APPROV.	DATE
7					
6					
5					
4					
3					
2					
1					

PREPARED UNDER THE SUPERVISION OF:

**TAIT**  
Since 1964

701 N. Parkcenter Drive  
Santa Ana, CA 92705  
p: 714/560/8200 f: 714/560/8211  
www.tait.com

Los Angeles Sacramento San Francisco Dallas Phoenix  
Ontario San Diego Boise Denver Portland

DESIGN ENGINEER R.C.E. No. DATE 9/12/22

DRAWN BY: DATE

DESIGNED BY: DATE

CHECKED BY: DATE

RECOMMENDED BY: DATE

**DANA POINT HARBOR REVITALIZATION**  
DANA POINT HARBOR PARTNERS, LLC

**BWP BURNHAM IWARD PROPERTIES** **R.D. OLSON DEVELOPMENT** **BELLWETHER FINANCIAL GROUP**

**BUILDINGS 6-12 AND SURFACE PARKING LOT PRECISE GRADING PLANS**

COMMERCIAL CORE WQMP DETAILS

SHT 4 OF 4

# **Attachment D: Orange County Tech. Guidance Doc. Maps**

SUBJECT TO FURTHER REVISION

**LEGEND**

- Orange County Precipitation Stations
- 24 Hour, 85th Percentile Rainfall (Inches)
- - - 24 Hour, 85th Percentile Rainfall (Inches) - Extrapolated
- City Boundaries

**Rainfall Zones**

**Design Capture Storm Depth (inches)**

- 0.65"
- 0.7
- 0.75
- 0.80
- 0.85
- 0.90
- 0.95
- 1.00
- 1.10"

Note: Events defined as 24-hour periods (calendar days) with greater than 0.1 inches of rainfall.  
For areas outside of available data coverage, professional judgment shall be applied.

**Site Location  
Depth = 0.8"**

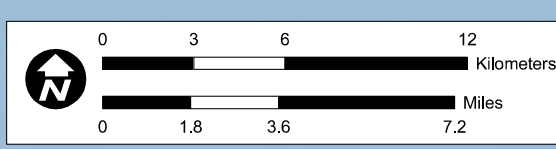

RAINFALL ZONES

ORANGE COUNTY  
TECHNICAL GUIDANCE  
DOCUMENT

SCALE	1" = 1.8 miles
DESIGNED	TH
DRAWING	TH
CHECKED	BMP
DATE	04/22/10
JOB NO.	9526-E



FIGURE  
**XVI-1**

P:\9526E\6-GIS\Mxd\Reports\Infiltration\Feasibility\_20110215\9526E\_FigureXVI-1\_RainfallZones\_20110215.mxd

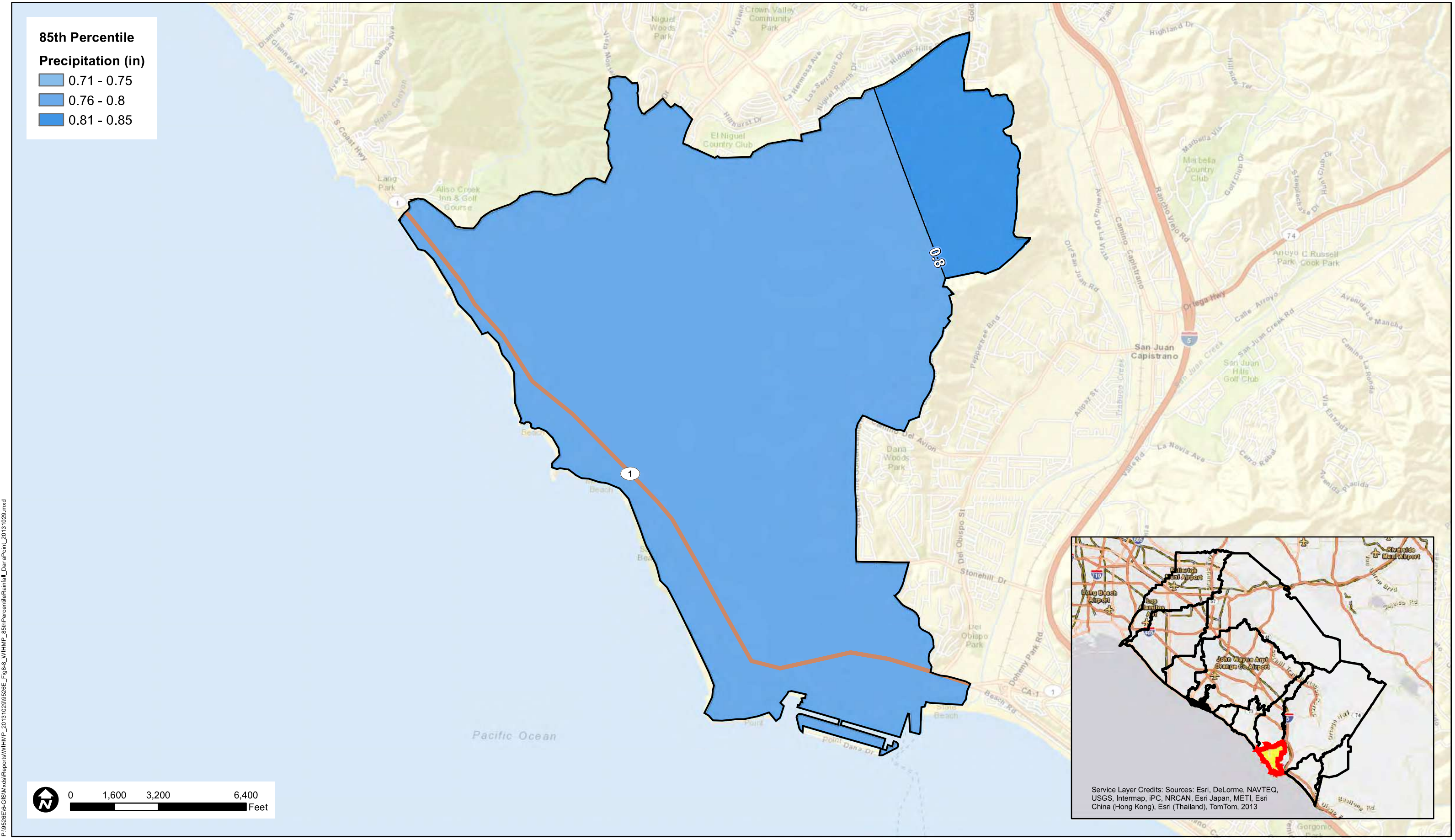

P:\9526E (G-3)S\Map\Reports\WIHMP\_20131029\9526E\_Fig8-8\_WIHMP\_85thPercentileRainfall\_DanaPoint\_20131029.mxd

**FIGURE 8.8  
PRECIPITATION - 85TH PERCENTILE  
DANA POINT WATERSHED**

SUBJECT TO FURTHER REVISION

**LEGEND**

City Boundaries

**Hydrologic Soil Groups**

- A Soils
- B Soils
- C Soils
- D Soils

Source:  
 Soils: Natural Resources Conservation Service (NRCS)  
 Soil Survey - soil\_ca678, Orange County & Western Riverside  
 Date of publication: 2006-02-08  
<http://websoilsurvey.nrcs.usda.gov/app/HomePage.htm>

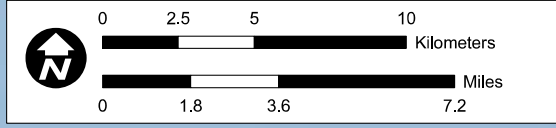
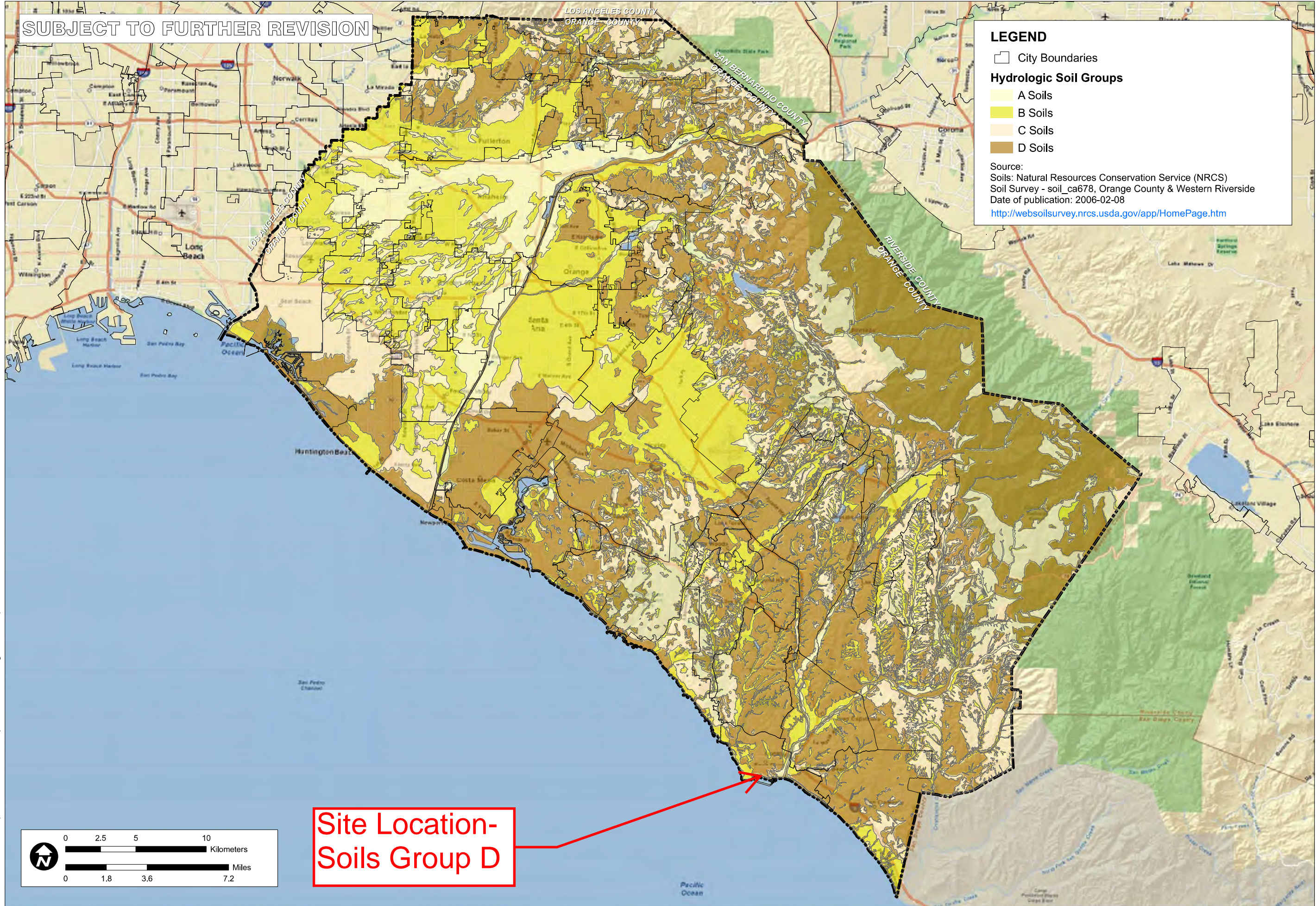

**Site Location-  
Soils Group D**

NRCS HYDROLOGIC  
SOILS GROUPS

ORANGE COUNTY  
INFILTRATION STUDY

SCALE	1" = 1.8 miles
DESIGNED	TH
DRAWING	TH
CHECKED	BMP
DATE	02/09/11
JOB NO.	9526-E



FIGURE  
**XVI-2a**

P:\9526E\6-GIS\Mxds\Reports\Infiltration\Feasibility\_20110215\9526E\_FigureXVI-2a\_HydroSoils\_20110215.mxd

SUBJECT TO FURTHER REVISION

**LEGEND**

□ City Boundaries

**Hydrologic Soil Groups**

■ D Soils

Source:  
D Soils: Natural Resources Conservation Service (NRCS)  
Soil Survey - soil\_ca678, Orange County & Western Riverside  
Date of publication: 2006-02-08

<http://websoilsurvey.nrcs.usda.gov/app/HomePage.htm>

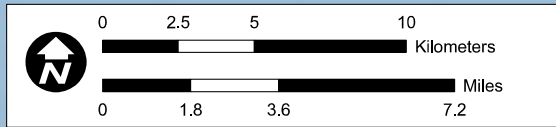
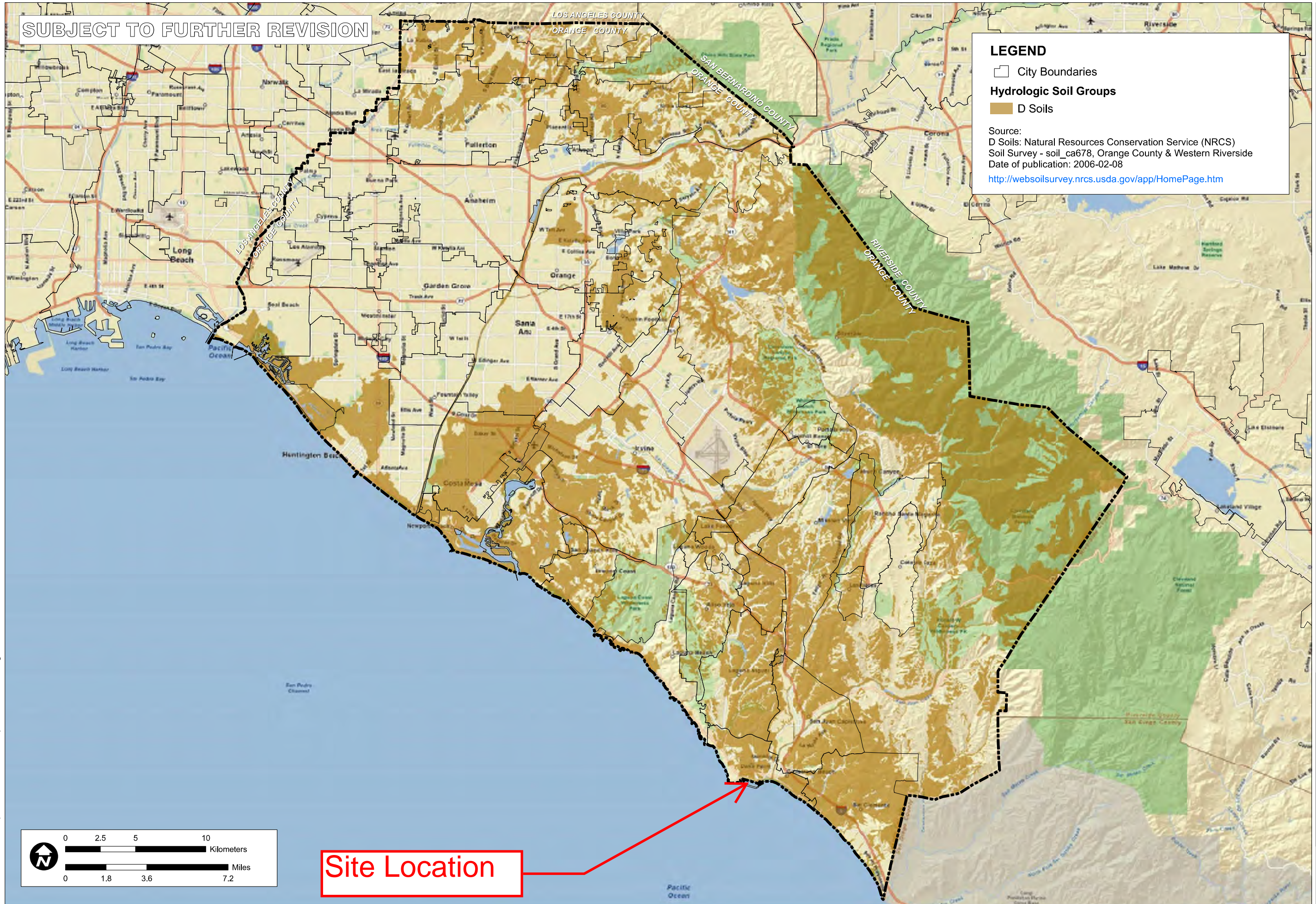

**Site Location**

TITLE  
HYDROLOGIC SOIL GROUP  
TYPE D NRCS SOIL SURVEY

JOB  
ORANGE COUNTY  
INFILTRATION STUDY  
ORANGE CO. CA

SCALE	1" = 1.8 miles
DESIGNED	TH
DRAWING	TH
CHECKED	BMP
DATE	02/09/11
JOB NO.	9526-E



FIGURE  
**XVI-2b**

P:\9526E\6-GIS\Mxd\Reports\Infiltration\Feasibility\_20110215\9526E\_FigureXVI-2b\_D-Soils\_20110215.mxd

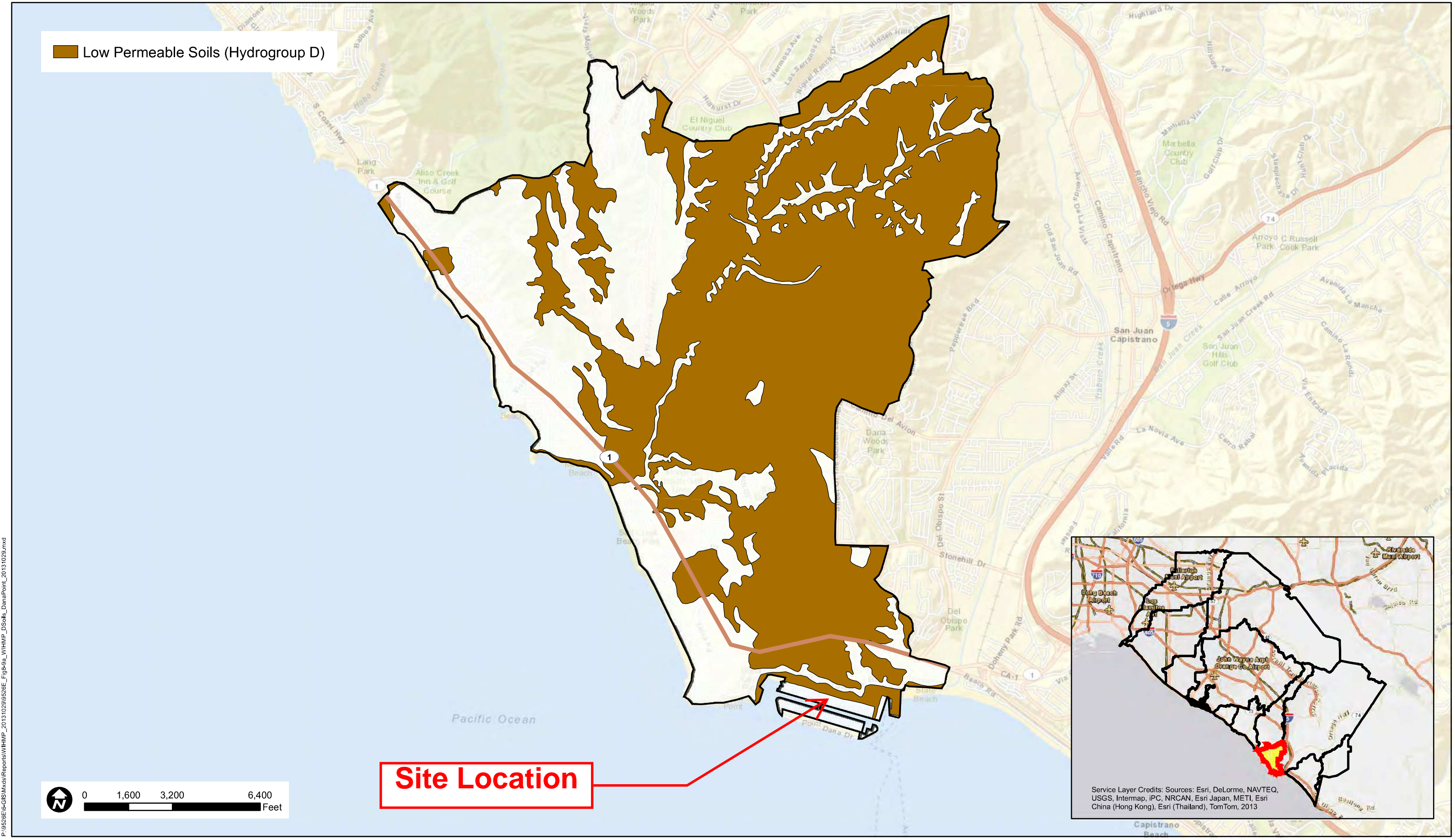

P:\9526E (GIS)\Mxd\Reports\WIHMP\_20131029\9526E\_Fig8-9a\_VIHMP\_DSols\_DanaPoint\_20131029.mxd

**FIGURE 8.9a**  
**INFILTRATION CONSTRAINT - D SOILS (LOW PERMEABILITY)**  
**DANA POINT WATERSHED**

SUBJECT TO FURTHER REVISION

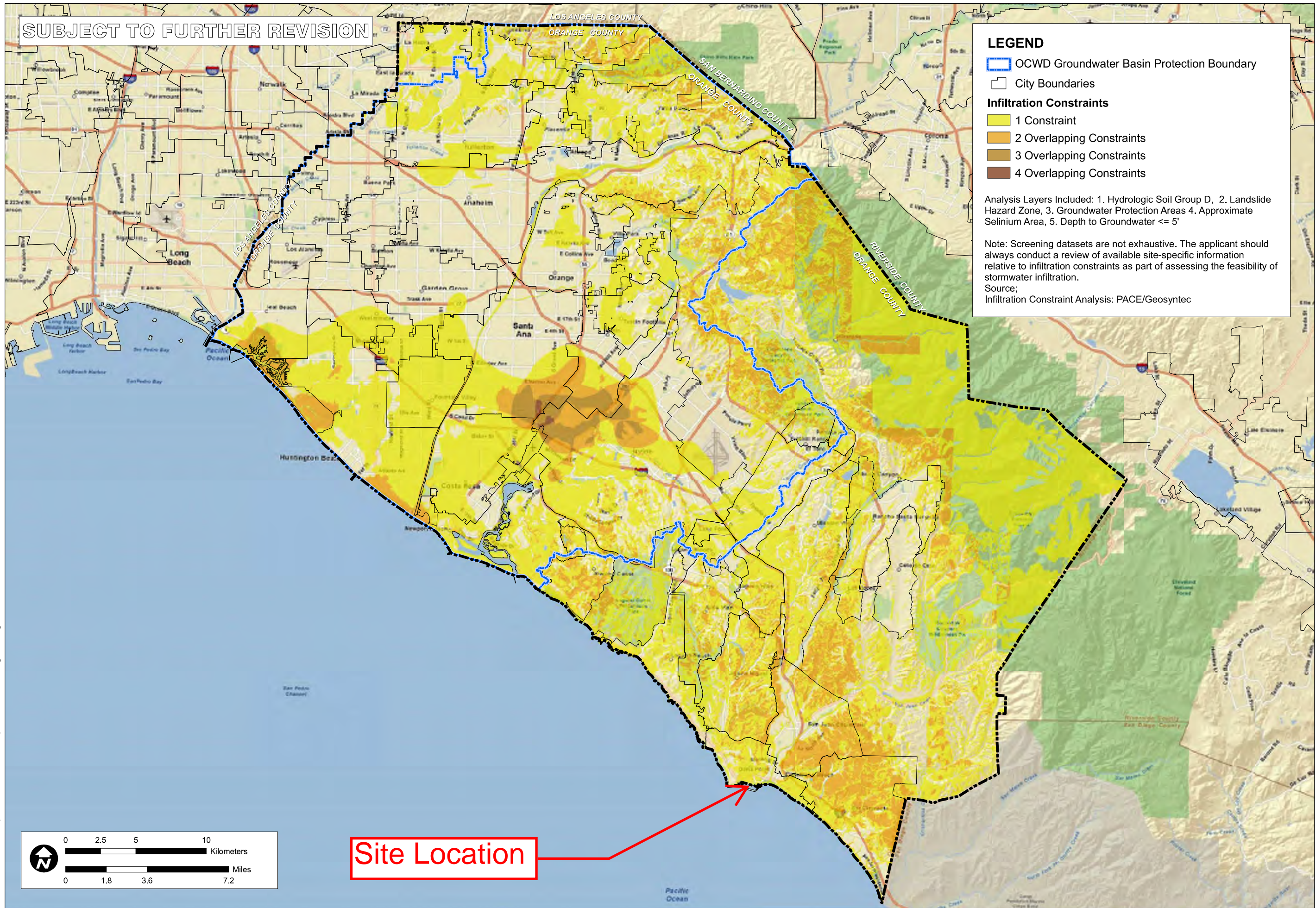

**LEGEND**

- OCWD Groundwater Basin Protection Boundary
- City Boundaries

**Infiltration Constraints**

- 1 Constraint
- 2 Overlapping Constraints
- 3 Overlapping Constraints
- 4 Overlapping Constraints

Analysis Layers Included: 1. Hydrologic Soil Group D, 2. Landslide Hazard Zone, 3. Groundwater Protection Areas 4. Approximate Selenium Area, 5. Depth to Groundwater <= 5'

Note: Screening datasets are not exhaustive. The applicant should always conduct a review of available site-specific information relative to infiltration constraints as part of assessing the feasibility of stormwater infiltration.  
Source; Infiltration Constraint Analysis: PACE/Geosyntec

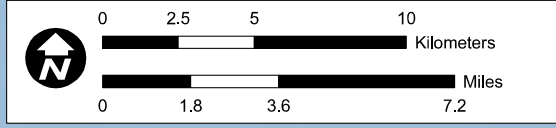

Site Location

<p><b>ORANGE COUNTY INFILTRATION STUDY</b></p>	<p><b>INFILTRATION ANALYSIS OVERLAPPING CONSTRAINT LOCATIONS</b></p>										
<p>ORANGE CO. CA</p>	<p>ORANGE CO. CA</p>										
<p>SCALE 1" = 1.8 miles</p> <table border="1" style="width: 100%; border-collapse: collapse;"> <tr> <td>DESIGNED</td> <td>TH</td> </tr> <tr> <td>DRAWING</td> <td>TH</td> </tr> <tr> <td>CHECKED</td> <td>BMP</td> </tr> <tr> <td>DATE</td> <td>04/22/10</td> </tr> <tr> <td>JOB NO.</td> <td>9526-E</td> </tr> </table>	DESIGNED	TH	DRAWING	TH	CHECKED	BMP	DATE	04/22/10	JOB NO.	9526-E	<p>FIGURE</p> <p><b>XVI-2g</b></p>
DESIGNED	TH										
DRAWING	TH										
CHECKED	BMP										
DATE	04/22/10										
JOB NO.	9526-E										

P:\9526E\6-GIS\Mxd\Reports\Infiltration\Feasibility\_20110215\9526E\_FigureXVI-2g\_InfiltrationFinal\_20110215.mxd

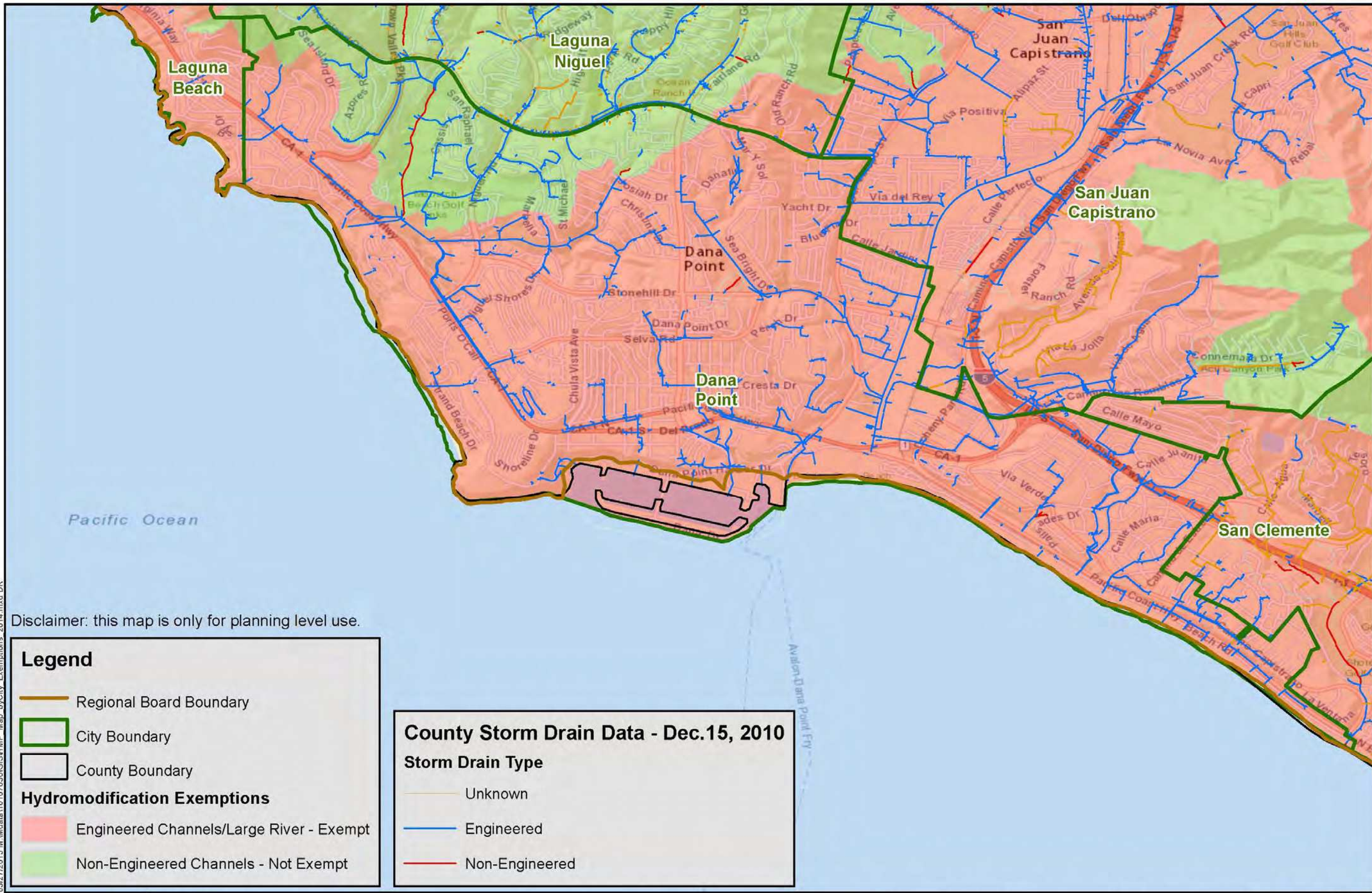

03/27/2015 M:\Mdata\10107630\GIS\HMP\_Map\_byCity\_Exemptions\_2014.mxd DR

Disclaimer: this map is only for planning level use.

**Legend**

- Regional Board Boundary
- City Boundary
- County Boundary

**Hydromodification Exemptions**

- Engineered Channels/Large River - Exempt
- Non-Engineered Channels - Not Exempt

**County Storm Drain Data - Dec.15, 2010**

**Storm Drain Type**

- Unknown
- Engineered
- Non-Engineered

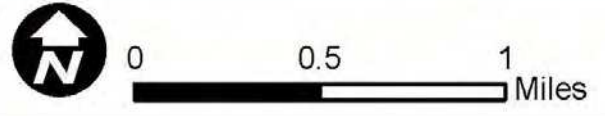

Sources: County of Orange; Caltrans; ESRI; RBF Consulting; San Diego RWQCB; SWRCB

**South Orange County Engineered Channel Exemption Areas  
Dana Point Exemption Map**



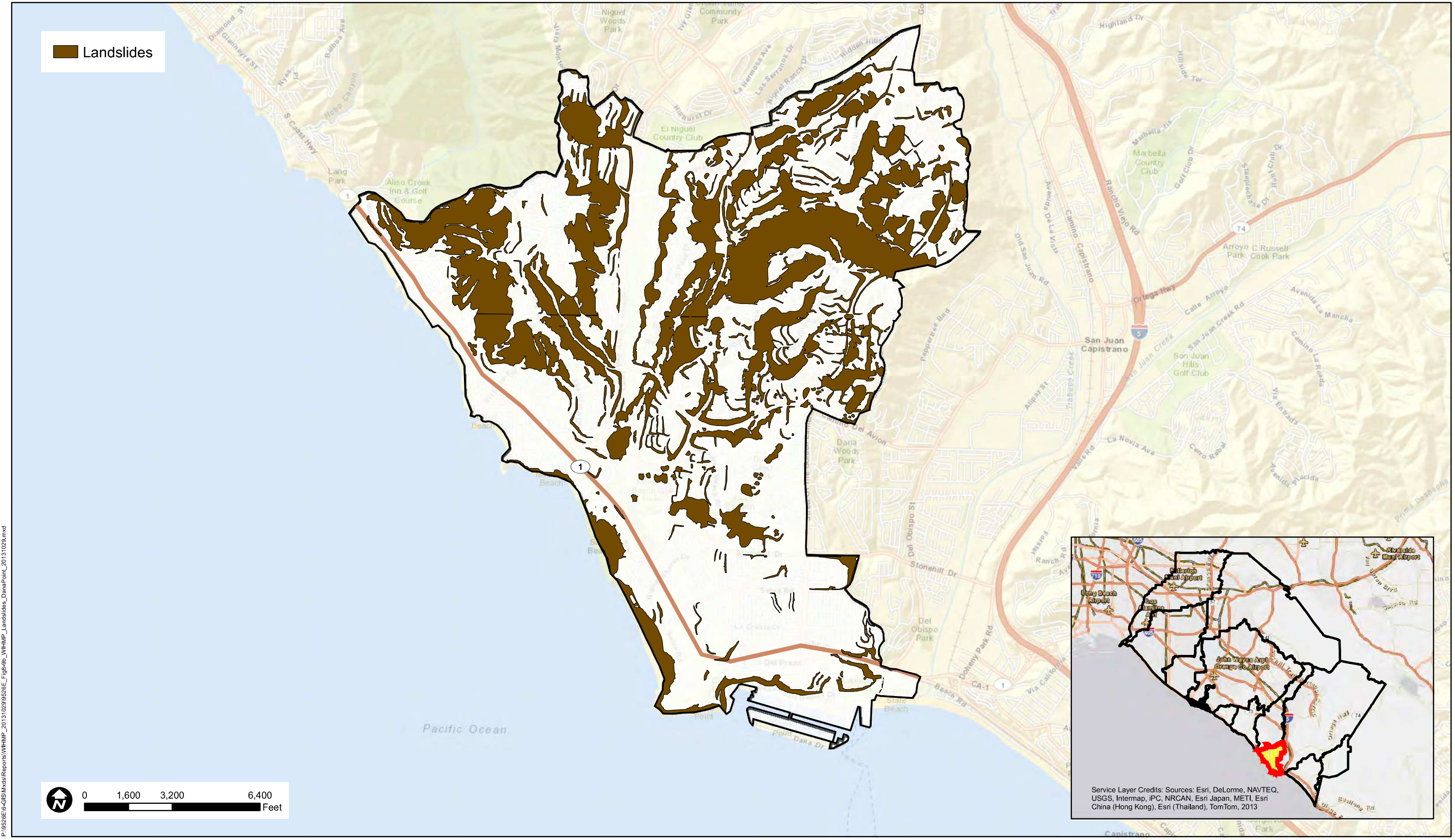

P:\952\BE-IGIS\Map\Reports\WIHMP\_20131029\952BE\_Fig8-5b\_VIHMP\_Landslides\_DanaPoint\_20131029.mxd

**FIGURE 8.5b**  
**INFILTRATION CONSTRAINT - LANDSLIDES**  
**DANA POINT WATERSHED**

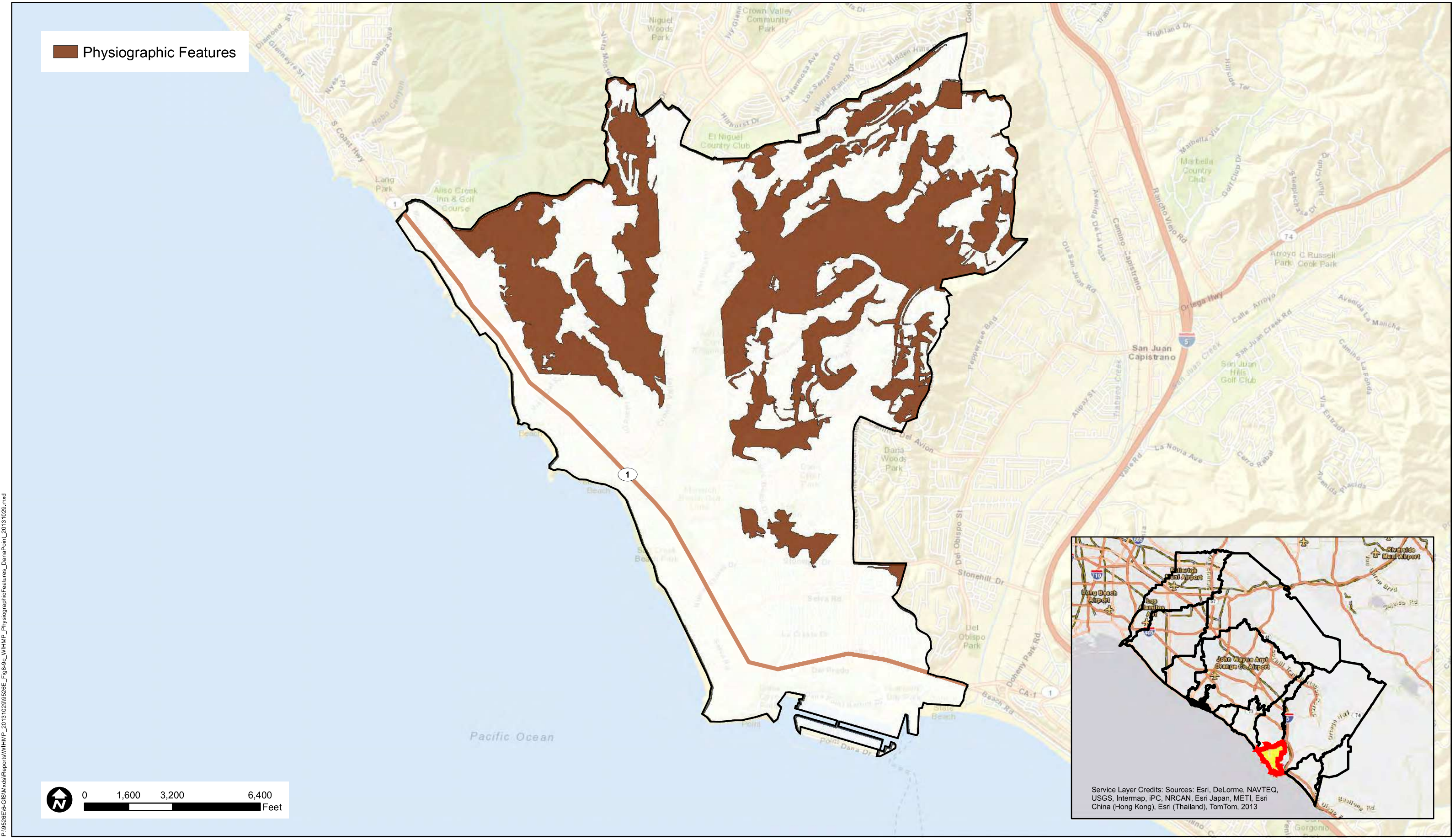

P:\9526E (G-3)S\mxd\Reports\WIHMP\_20131029\9526E\_Fig8-9c\_PhysiographicFeatures\_DanaPoint\_20131029.mxd

**FIGURE 8.9c**  
**INFILTRATION CONSTRAINT - PHYSIOGRAPHIC FEATURES**  
**DANA POINT WATERSHED**

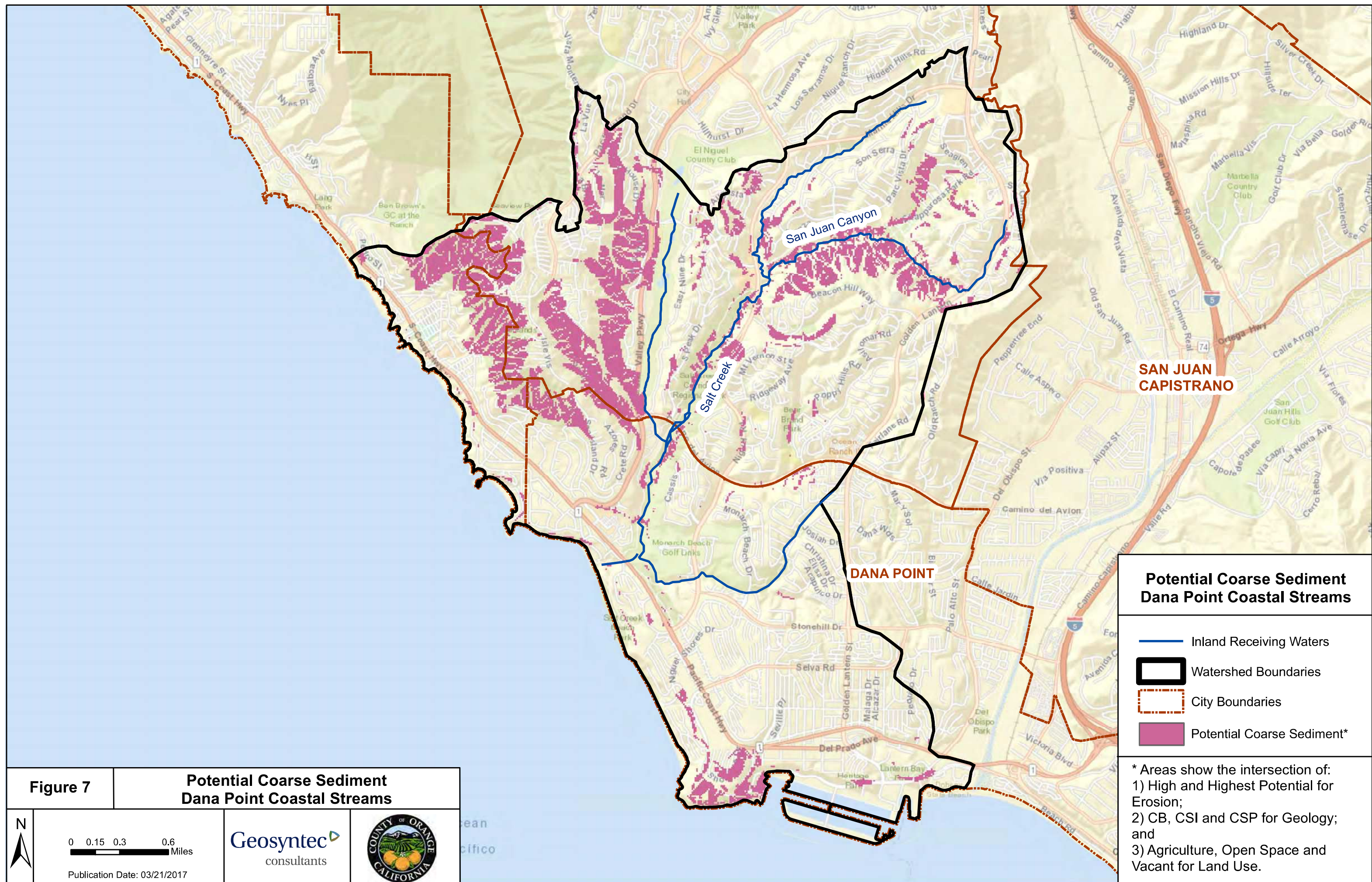

**Figure 7**

**Potential Coarse Sediment  
Dana Point Coastal Streams**







0 0.15 0.3 0.6 Miles

Publication Date: 03/21/2017

**Geosyntec**  
consultants



**Potential Coarse Sediment  
Dana Point Coastal Streams**

-  Inland Receiving Waters
-  Watershed Boundaries
-  City Boundaries
-  Potential Coarse Sediment\*

\* Areas show the intersection of:  
 1) High and Highest Potential for Erosion;  
 2) CB, CSI and CSP for Geology;  
 and  
 3) Agriculture, Open Space and Vacant for Land Use.

**Infiltration Constraint Area**  
**# of Overlapping Constraints**

0
1
2
3
4

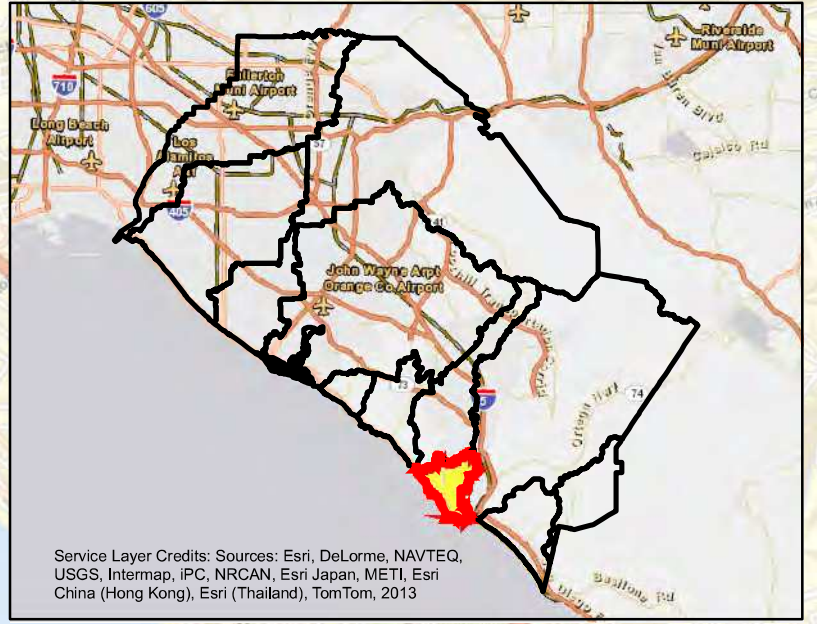
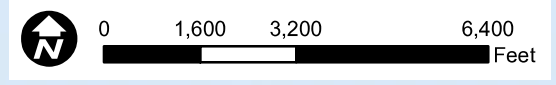
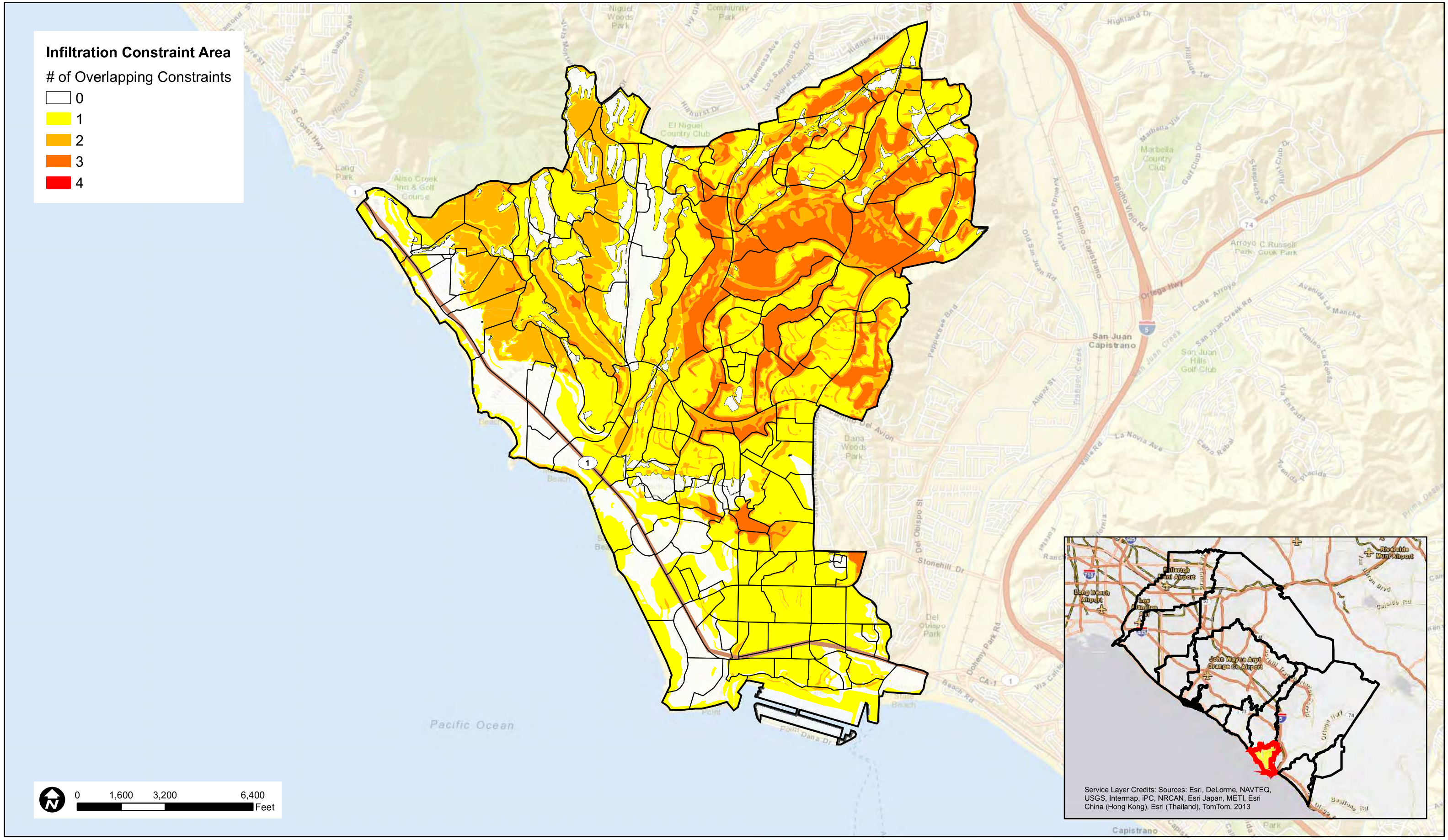

Service Layer Credits: Sources: Esri, DeLorme, NAVTEQ, USGS, Intermap, IPC, NRCAN, Esri Japan, METI, Esri China (Hong Kong), Esri (Thailand), TomTom, 2013

**FIGURE 8.9**  
**INFILTRATION CONSTRAINT - OVERALL CONSTRAINTS**  
**DANA POINT WATERSHED**

# **Attachment E: Calculations and Worksheets**

**Worksheet 1: Infiltration Feasibility Categorization**

<b>Categorization of Infiltration Feasibility Condition</b>			<b>Page 1 of 5</b>
<b>Part 1: Physical Limitations of Infiltration</b>			
Based on the criteria for physical limitations of infiltration described in <a href="#">Section 4.2.2.2</a> , what level of physical feasibility of infiltration is the maximum that the BMP location will support?			
<b>1</b>	<b>Physical Infiltration Feasibility Category</b>	<b>Mark applicable category</b>	<b>Next step</b>
	Full Infiltration of the DCV		Continue to Part 2
	Biotreatment with Partial Infiltration		Continue to Part 3
	Biotreatment with No Infiltration	<b>X</b>	Select and Utilize Biotreatment without Infiltration
<p>Provide summary of basis:                      The project does not propose the use of an infiltration system. The project areas are located directly next to the marina/harbor. The groundwater is approx. 5' to 15' below ground surface elevation around the site. The historical high groundwater around the site is approx. 5' below ground surface elevation. Pollutants would migrate directly into the groundwater, since not enough soil lies between the bottom of an infiltration system and the groundwater table. In addition, groundwater elevations across the site are controlled by the elevation of the water within the adjacent harbor but are also somewhat influenced by the pre-development topography, with lower elevations found closest to the seawall. Groundwater elevations measured during the exploration were affected by the time of day as it relates to the local tidal cycle, and therefore should be assumed to fluctuate with the tides, the lunar cycle, and recent rainfall events.</p> <p>Summarize findings of studies, provide reference to studies, calculations, maps, data sources, etc. Provide narrative discussion of study/data source applicability.</p>			

<b>Categorization of Infiltration Feasibility Condition</b>		<b>Page 2 of 5</b>	
<b>Part 2: Risks Limiting Full Infiltration of the DCV –Would infiltration of the full DCV introduce risks of undesirable consequences that cannot reasonably be mitigated?</b>		<b>Yes</b>	<b>No</b>
2	<b>Would infiltration of the DCV pose significant risk for groundwater related concerns?</b> Use criteria described in Section 4.2.2.3 and results from <b>Worksheet 2 (Appendix C)</b> to describe groundwater-related infiltration feasibility criteria.	<b>X</b>	
Provide basis:  <p style="text-align: center; color: blue; font-size: 1.2em;"><b>See previous section</b></p>			
Summarize findings of studies provide reference to studies, calculations, maps, data sources, etc. Provide narrative discussion of study/data source applicability.			
3	<b>Would infiltration of the full DCV pose significant risk of increasing risk of geotechnical hazards that cannot be mitigated to an acceptable level?</b> Use criteria described in <b>Section 4.2.2.4.</b>		<b>X</b>
Provide basis:  			
Summarize findings of studies provide reference to studies, calculations, maps, data sources, etc. Provide narrative discussion of study/data source applicability.			
4	Would infiltration of the DCV cause an increase in groundwater flow or decrease in surface runoff over predevelopment conditions that would cause <b>impairment to downstream beneficial uses, such as change of seasonality of ephemeral washes or increased discharge of contaminated groundwater to surface waters?</b> Use criteria in <b>Section 4.2.2.5.</b>		<b>X</b>
Provide basis:  			
Summarize findings of studies provide reference to studies, calculations, maps, data sources, etc. Provide narrative discussion of study/data source applicability.			





<b><i>Categorization of Infiltration Feasibility Condition</i></b>		<b><i>Page 5 of 5</i></b>
<b>Part 3 Result</b>	<p>If the answer to all questions 8-10 are “No”, then the DMA is categorized as “Biotreatment with Partial Infiltration” for the purposes of LID BMP type selection.</p> <p>If the answer to any of questions 8-10 is “Yes” then the site is categorized as “Biotreatment with No Infiltration” for the purposes of LID BMP type selection.</p>	X

# STORMVAULT WITH 10-PACK STORMSAFE CARTRIDGES STORMWATER TREATMENT BMP NO. 12

**HYDRAULICS AND TREATMENT:**

STORMWATER QUALITY DESIGN FLOW (SQDF)	0.967-CFS (434-GPM)
STORM DRAIN DESIGN PEAK CONVEYANCE FLOW	2.56-CFS
RETURN FREQUENCY / PERIOD OF PEAK DESIGN CONVEYANCE FLOW	2 - YEARS

**TREATMENT PERFORMANCE NOTES:**

MEDIA FILTER SUBSTRATA	PATHOGEN CARTRIDGE
NUMBER OF CARTRIDGES	10
INDIVIDUAL CARTRIDGE ULTIMATE MAXIMUM LOADING RATE	115-GPM / CART
HYDRAULIC DRIVING HEAD	6-INCHES

THE STORMSAFE FILTER CARTRIDGE (BY FABCO) EMPLOYS A PATENTED ANTI-MICROBIAL MEDIA TO TREAT STORMWATER. THE TREATMENT PROCESS IS DESIGNED TO ACHIEVE BACTERIA REDUCTION THROUGH CELLULAR DISRUPTION, AS WELL AS BASIC SEDIMENTATION AND PHYSICAL FILTRATION OF TOTAL SUSPENDED SOLIDS (TSS) AND GROSS SOLIDS AND DEBRIS REMOVAL. THE STORMSAFE PATHOGEN CARTRIDGE ACHIEVES THE FOLLOWING EFFLUENT DISCHARGE WATER QUALITY GOALS:

- SPECIFICALLY TARGETS AND KILLS 50 TO 70% OF THE BACTERIA IN STORMWATER
- PROVEN CAPABLE OF REDUCING THE FOLLOWING TYPES OF INDICATOR BACTERIA:
  - 77% E.COLI
  - 77% FECAL COLIFORM
  - 49% ENTEROCOCCUS
- NO ATTENUATION OR DISSIPATION OF BACTERIA REMOVAL EFFICIENCY OVER TIME REGARDLESS OF TOTAL MASS LOADING
- NO TOXICITY RESIDUAL IMPACTS TO DOWNSTREAM BIOTA
- REMOVAL OF OIL AND GREASE

**DESIGN GUIDANCE NOTES:**

1. FILTER CARTRIDGES SHALL BE OPEN CELL FOAM SUBSTRATA MEDIA WITH THE PATENTED CHEMICAL CHARGED COATING ON POLYMER OPEN CELL FOAM SUBSTRATA MEDIA.
2. THE DEPTH OF THE POLYMER MEDIA SHALL BE NOT LESS THAN 11-INCHES IN DEPTH / THICKNESS.
3. THE SPECIFIC HYDRAULIC LOADING RATE OF THE FILTRATION MEDIA SHALL BE NO MORE THAN THE VALUE SHOWN IN THE STORMSAFE FILTER TREATMENT DESIGN TABLE ABOVE.
4. GROUNDWATER ELEVATION IS ASSUMED TO BE BELOW THE BOTTOM OF PRECAST STRUCTURE. CONTACT JENSEN STORMWATER SYSTEMS FOR HIGH GROUNDWATER CONDITIONS.
5. FOUNDATION, SUBGRADE, AND BACKFILL TO BE DESIGNED BY OTHERS.

**GENERAL NOTES:**

1. STANDARD CONFIGURATION IS SHOWN. CONTACT JENSEN STORMWATER SYSTEMS FOR CUSTOM DESIGNS, [www.jensenengineersystems.com](http://www.jensenengineersystems.com).
2. PLAN VIEW TOP SLAB WITH FRAMES AND COVERS ARE NOT SHOWN FOR CLARITY.
3. JENSEN STORMWATER SYSTEMS TO PROVIDE ALL MATERIALS SHOWN, UNLESS OTHERWISE NOTED.

**CONSTRUCTION / INSTALLATION NOTES:**

1. CONTRACTOR TO VERIFY VERTICAL DIMENSIONS OF ALL PRECAST PIECES IN FIELD.
2. VERIFY SUBBASE ELEVATION BEFORE PLACING PRECAST COMPONENTS OR BACKFILLING.
3. APPLY BUTYL MASTIC AND/OR GROUT TO SEAL JOINTS OF STRUCTURE.
4. APPLY LOAD TO MASTIC SEAL IN JOINTS OF VAULT/MANHOLE SECTIONS TO COMPRESS SEALANT IF NECESSARY. UNIT MUST BE WATER TIGHT, HOLDING WATER UP TO FLOWLINE INVERT (MINIMUM).
5. CONTRACTOR TO GROUT SEAL INLET AND DISCHARGE PIPES TO VAULT/MANHOLE WALL.
6. BLOCK AND/OR GROUT PACK BENEATH FRAMES AND COVERS TO MATCH FINISHED GRADE.

**MATERIALS:**

1. ALL DIMENSIONS ARE IN FEET OR FRACTIONAL INCHES
2. PRECAST MATERIALS AND MANUFACTURING METHODS SHALL CONFORM TO ASTM C-857.
3. CONCRETE SHALL HAVE A MINIMUM COMPRESSIVE STRENGTH  $F'c = 5,000$  - psi AT 28-DAYS
4. THE PORTLAND CEMENT USED IN THE PRECAST SECTION SHALL MEET THE REQUIREMENTS OF TYPE III/ HIGH SULFATE RESISTANT CEMENT IN ACCORDANCE WITH ASTM CLASS M C-150
5. ALL METAL WORK SHALL BE ASTM 316L MARINE GRADE STAINLESS STEEL

**LIFTING WEIGHTS:**

1. HEAVIEST PICK WEIGHT IS 23,000-LBS
2. JENSEN CRANE TRUCK CAN SET A MAXIMUM OF 25,000-LBS AT 15-FT OFFSET DISTANCE FROM CENTER OF CRANE TRUNNION

**MATERIAL LIST - PROVIDED WITH UNIT:**

QTY	COMPONENT DESCRIPTION	PROVIDER	INSTALLER
10	STORM SAFE PATHOGEN FILTER CARTRIDGES	JENSEN	JENSEN
AS REQ'D	30" GRADE RING	JENSEN	CONTRACTOR
2	30" CAST IRON RING AND COVER	JENSEN	CONTRACTOR

**(\*) REGIONAL MANUFACTURING DIFFERENCE:**

THESE ARE TEMPLATE SITE DESIGN DRAWINGS. JOINT ORIENTATIONS AND FINAL WALL/BASE THICKNESS VARY ACROSS JENSEN'S REGIONAL MANUFACTURING FACILITIES. CONFIRM FINAL JOINT ORIENTATION AND THICKNESS PER CONSTRUCTION SUBMITTAL DRAWINGS. ADJUST FINAL DIMENSIONS TO EXTERIOR INVERT AND SUBGRADE ELEVATION PER REGION DIFFERENCES.

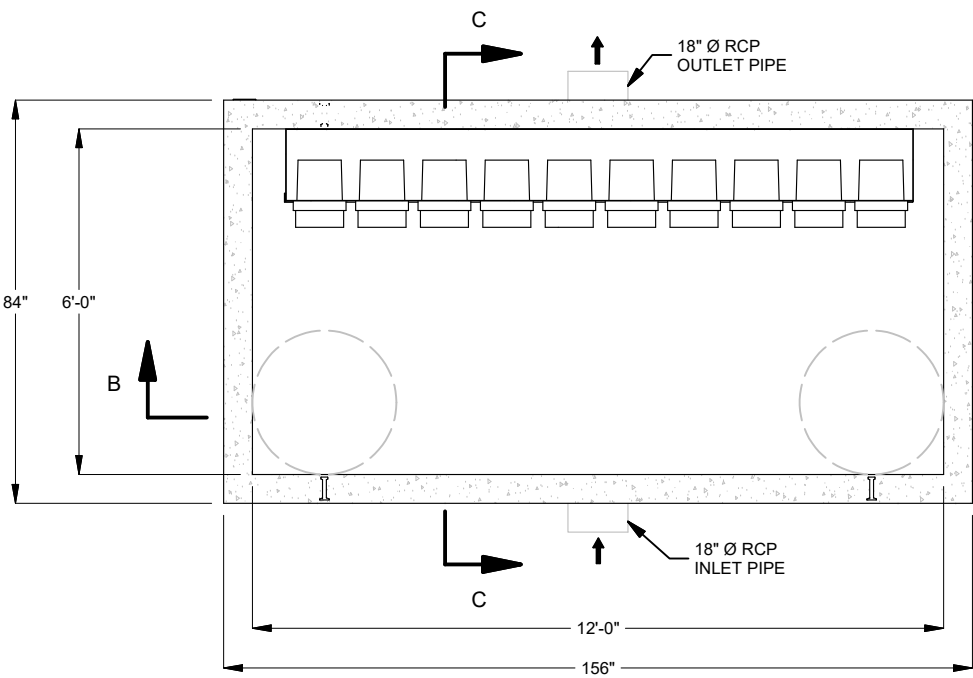

**PLAN VIEW**

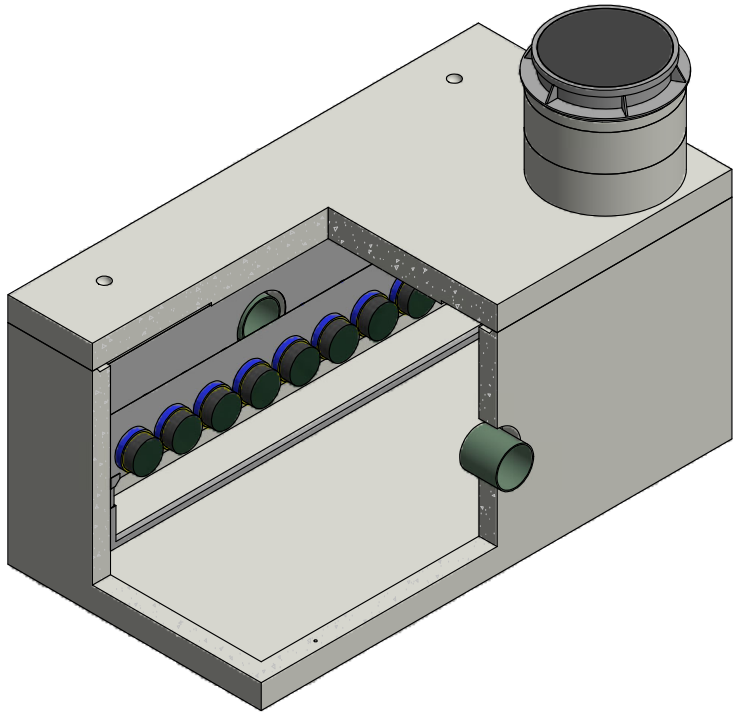

**ISO VIEW**

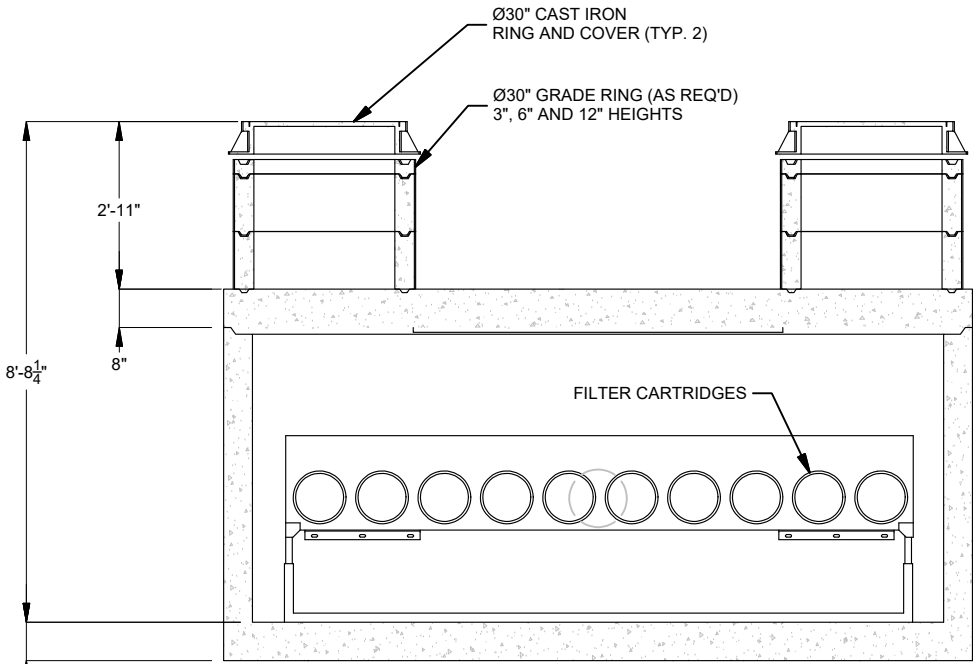

**SECTION B-B**

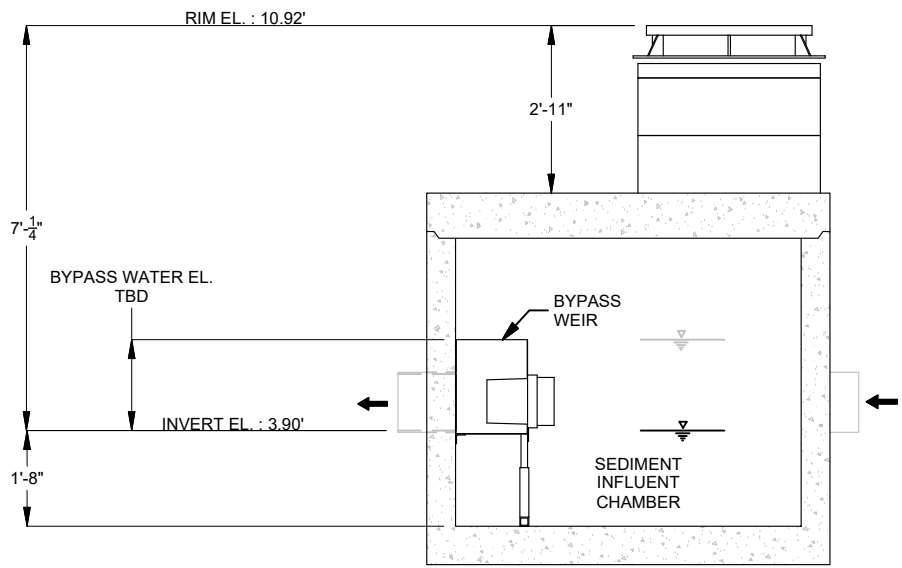

**SECTION C-C**

**DISCLAIMERS, INCLUDING BUT NOT LIMITED TO:**

- 1.) All elevations have been provided by others, and have not been verified by Jensen Precast. Contractor to verify all dimensions and elevations in field prior to installation.
- 2.) These layout drawings are intended to show overall system design only. All concrete component thicknesses, dimensions, and joint orientations may vary across Jensen Precast's manufacturing facilities. Contractor to confirm all thicknesses, dimensions, and joint orientations prior to installation.
- 3.) System design criteria has been provided to Jensen Precast. Others are responsible for verification that system meets intended application.
- 4.) Foundation, subgrade, and backfill to be designed by others.

**JENSEN** STORMWATER SYSTEMS

521 DUNN CIRCLE, SPARKS, NV 89431  
[www.jensenwaterresources.com](http://www.jensenwaterresources.com)  
 (855) 468-5600

©2018 Jensen Precast - All rights reserved.

All materials appearing as Jensen Precast documents and the like are proprietary work product and are protected under U.S. copyright and other laws.

Unless in conjunction with business conducted with Jensen Precast, any use of Jensen Precast work product without express, written consent is prohibited, and recipient is prohibited from distributing any and all work product to non-approved third parties under penalty of civil action.

PROJECT:	HARBOR REVITALIZATION - BMP #12 DANA POINT, CA		REV:
PART NUMBER:	200063153	DRAWN BY:	rasal9
CREATED:		MODIFIED:	8/31/2022
			SHEET: 1 OF 1

200063153.rdw

# STORMVAULT WITH 3-PACK STORMSAFE CARTRIDGES STORMWATER TREATMENT BMP #13

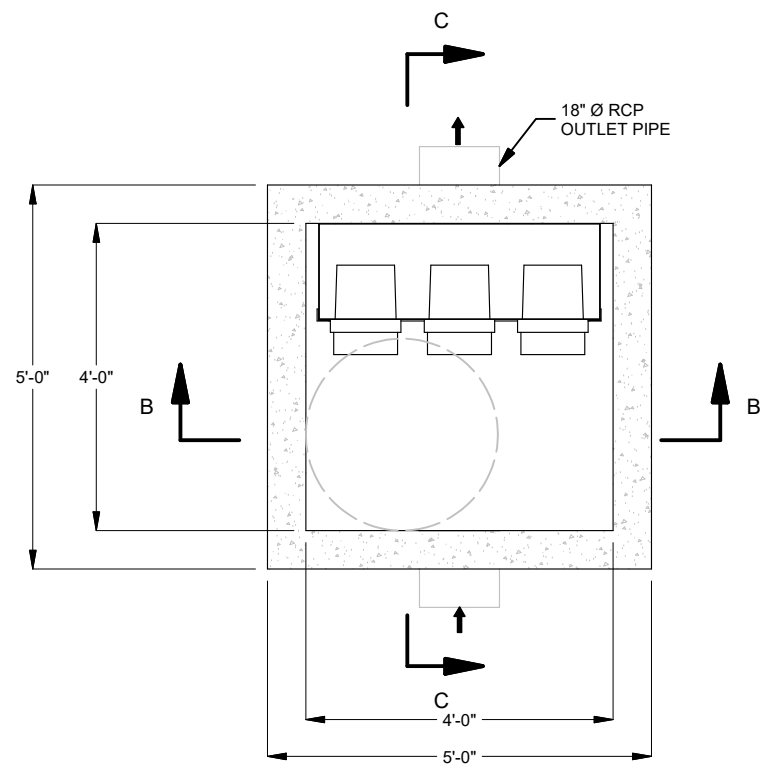

**PLAN VIEW**

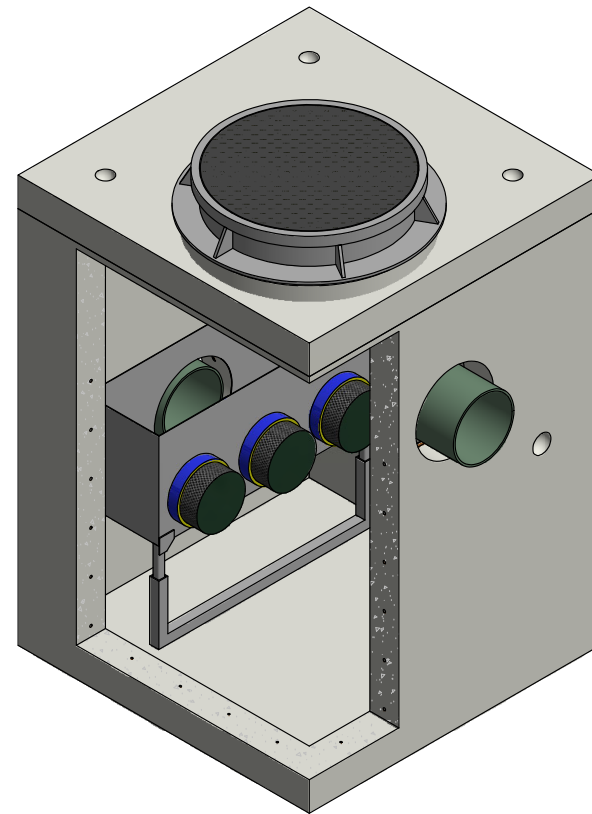

**ISO VIEW**

**HYDRAULICS AND TREATMENT:**

STORMWATER QUALITY DESIGN FLOW (SQDF)	≤ 0.228-CFS
STORM DRAIN DESIGN PEAK CONVEYANCE FLOW	0.768-CFS
RETURN FREQUENCY / PERIOD OF PEAK DESIGN CONVEYANCE FLOW	2 - YEARS

**TREATMENT PERFORMANCE NOTES:**

MEDIA FILTER SUBSTRATA	PATHOGEN CARTRIDGE
NUMBER OF CARTRIDGES	3
INDIVIDUAL CARTRIDGE ULTIMATE MAXIMUM LOADING RATE	115-GPM / CART
HYDRAULIC DRIVING HEAD	6-INCHES

THE STORMSAFE FILTER CARTRIDGE (BY FABCO) EMPLOYS A PATENTED ANTI-MICROBIAL MEDIA TO TREAT STORMWATER. THE TREATMENT PROCESS IS DESIGNED TO ACHIEVE BACTERIA REDUCTION THROUGH CELLULAR DISRUPTION, AS WELL AS BASIC SEDIMENTATION AND PHYSICAL FILTRATION OF TOTAL SUSPENDED SOLIDS (TSS) AND GROSS SOLIDS AND DEBRIS REMOVAL. THE STORMSAFE PATHOGEN CARTRIDGE ACHIEVES THE FOLLOWING EFFLUENT DISCHARGE WATER QUALITY GOALS:

- SPECIFICALLY TARGETS AND KILLS 50 TO 70% OF THE BACTERIA IN STORMWATER
- PROVEN CAPABLE OF REDUCING THE FOLLOWING TYPES OF INDICATOR BACTERIA:
  - 77% E. COLI
  - 77% FECAL COLIFORM
  - 49% ENTEROCOCCUS
- NO ATTENUATION OR DISSIPATION OF BACTERIA REMOVAL EFFICIENCY OVER TIME REGARDLESS OF TOTAL MASS LOADING
- NO TOXICITY RESIDUAL IMPACTS TO DOWNSTREAM BIOTA
- REMOVAL OF OIL AND GREASE

**DESIGN GUIDANCE NOTES:**

1. FILTER CARTRIDGES SHALL BE OPEN CELL FOAM SUBSTRATA MEDIA WITH THE PATENTED CHEMICAL CHARGED COATING ON POLYMER OPEN CELL FOAM SUBSTRATA MEDIA.
2. THE DEPTH OF THE POLYMER MEDIA SHALL BE NOT LESS THAN 11-INCHES IN DEPTH / THICKNESS.
3. THE SPECIFIC HYDRAULIC LOADING RATE OF THE FILTRATION MEDIA SHALL BE NO MORE THAN THE VALUE SHOWN IN THE STORMSAFE FILTER TREATMENT DESIGN TABLE ABOVE.
4. GROUNDWATER ELEVATION IS ASSUMED TO BE BELOW THE BOTTOM OF PRECAST STRUCTURE. CONTACT JENSEN STORMWATER SYSTEMS FOR HIGH GROUNDWATER CONDITIONS.
5. FOUNDATION, SUBGRADE, AND BACKFILL TO BE DESIGNED BY OTHERS.

**GENERAL NOTES:**

1. STANDARD CONFIGURATION IS SHOWN. CONTACT JENSEN STORMWATER SYSTEMS FOR CUSTOM DESIGNS, [www.jensenengineersystems.com](http://www.jensenengineersystems.com).
2. PLAN VIEW TOP SLAB WITH FRAMES AND COVERS ARE NOT SHOWN FOR CLARITY.
3. JENSEN STORMWATER SYSTEMS TO PROVIDE ALL MATERIALS SHOWN, UNLESS OTHERWISE NOTED.

**CONSTRUCTION / INSTALLATION NOTES:**

1. CONTRACTOR TO VERIFY VERTICAL DIMENSIONS OF ALL PRECAST PIECES IN FIELD.
2. VERIFY SUBBASE ELEVATION BEFORE PLACING PRECAST COMPONENTS OR BACKFILLING.
3. APPLY BUTYL MASTIC AND/OR GROUT TO SEAL JOINTS OF STRUCTURE.
4. APPLY LOAD TO MASTIC SEAL IN JOINTS OF VAULT/MANHOLE SECTIONS TO COMPRESS SEALANT IF NECESSARY. UNIT MUST BE WATER TIGHT, HOLDING WATER UP TO FLOWLINE INVERT (MINIMUM).
5. CONTRACTOR TO GROUT SEAL INLET AND DISCHARGE PIPES TO VAULT/MANHOLE WALL.
6. BLOCK AND/OR GROUT PACK BENEATH FRAMES AND COVERS TO MATCH FINISHED GRADE.

**MATERIALS:**

1. ALL DIMENSIONS ARE IN FEET OR FRACTIONAL INCHES
2. PRECAST MATERIALS AND MANUFACTURING METHODS SHALL CONFORM TO ASTM C-857.
3. CONCRETE SHALL HAVE A MINIMUM COMPRESSIVE STRENGTH F' c = 5,000 - psi AT 28-DAYS
4. THE PORTLAND CEMENT USED IN THE PRECAST SECTION SHALL MEET THE REQUIREMENTS OF TYPE II/V HIGH SULFATE RESISTANT CEMENT IN ACCORDANCE WITH ASTM CLASS M C-150
5. ALL METAL WORK SHALL BE ASTM 316L MARINE GRADE STAINLESS STEEL

**LIFTING WEIGHTS:**

1. HEAVIEST PICK WEIGHT IS 7,250-LBS
2. JENSEN CRANE TRUCK CAN SET A MAXIMUM OF 25,000-LBS AT 15-FT OFFSET DISTANCE FROM CENTER OF CRANE TRUNNION

**MATERIAL LIST - PROVIDED WITH UNIT:**

QTY	COMPONENT DESCRIPTION	PROVIDER	INSTALLER
3	STORM SAFE PATHOGEN FILTER CARTRIDGES	JENSEN	JENSEN
AS REQ'D	30" GRADE RING	JENSEN	CONTRACTOR
1	30" CAST IRON RING AND COVER	JENSEN	CONTRACTOR

**(\* ) REGIONAL MANUFACTURING DIFFERENCE:**

THESE ARE TEMPLATE SITE DESIGN DRAWINGS. JOINT ORIENTATIONS AND FINAL WALL/BASE THICKNESS VARY ACROSS JENSEN'S REGIONAL MANUFACTURING FACILITIES. CONFIRM FINAL JOINT ORIENTATION AND THICKNESS PER CONSTRUCTION SUBMITTAL DRAWINGS. ADJUST FINAL DIMENSIONS TO EXTERIOR INVERT AND SUBGRADE ELEVATION PER REGION DIFFERENCES.

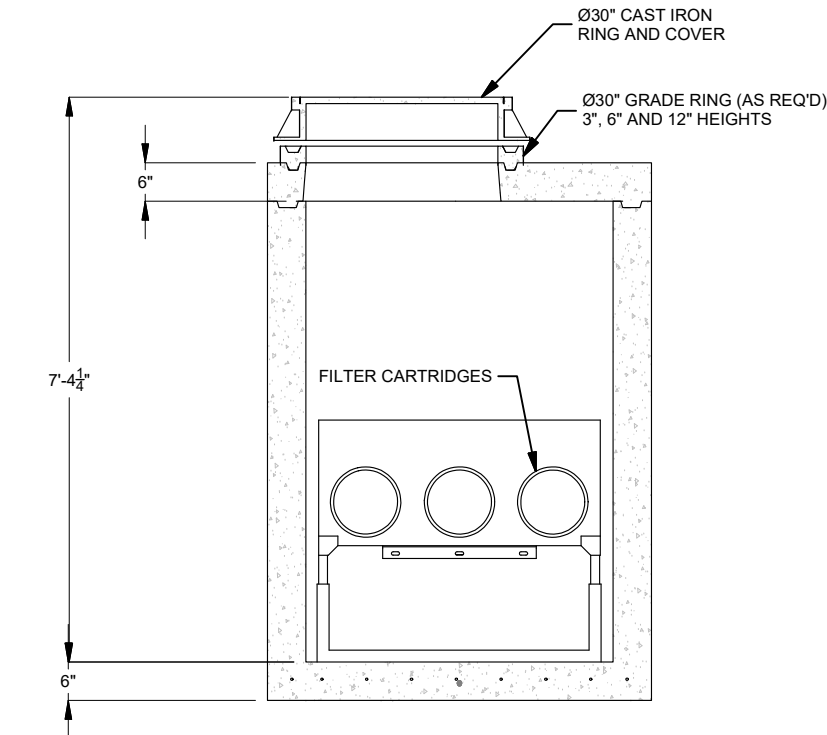

**SECTION B-B**

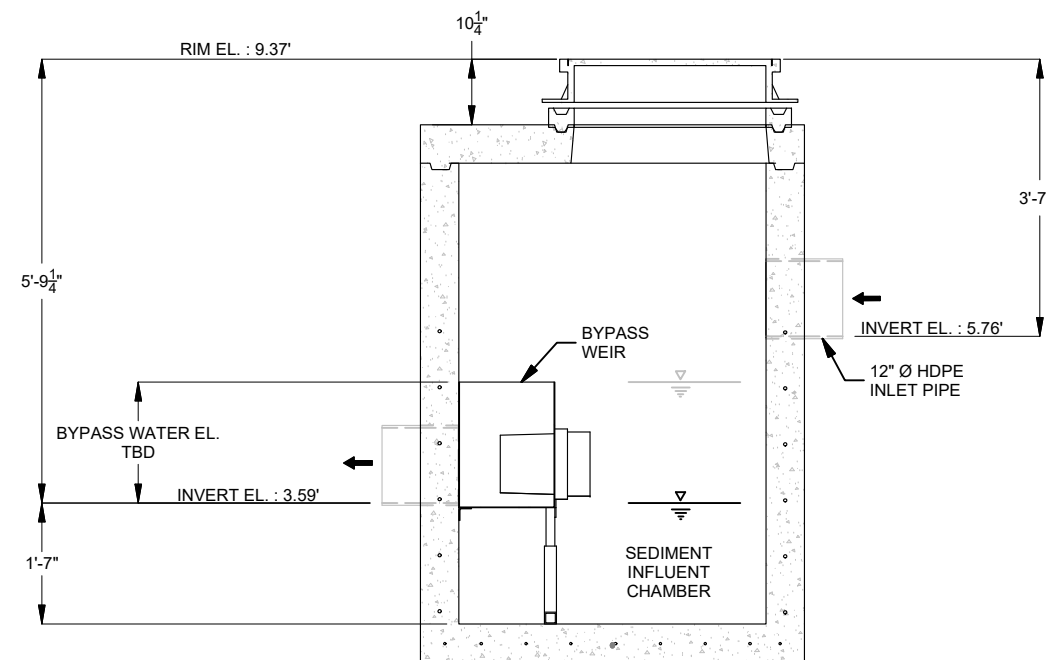

**SECTION C-C**

**DISCLAIMERS, INCLUDING BUT NOT LIMITED TO:**

- 1.) All elevations have been provided by others, and have not been verified by Jensen Precast. Contractor to verify all dimensions and elevations in field prior to installation.
- 2.) These layout drawings are intended to show overall system design only. All concrete component thicknesses, dimensions, and joint orientations may vary across Jensen Precast's manufacturing facilities. Contractor to confirm all thicknesses, dimensions, and joint orientations prior to installation.
- 3.) System design criteria has been provided to Jensen Precast. Others are responsible for verification that system meets intended application.
- 4.) Foundation, subgrade, and backfill to be designed by others.

**JENSEN** STORMWATER SYSTEMS  
 521 DUNN CIRCLE, SPARKS, NV 89431  
[www.jensenwaterresources.com](http://www.jensenwaterresources.com)  
 (855) 468-5600

©2018 Jensen Precast - All rights reserved.  
 All materials appearing as Jensen Precast documents and the like are proprietary work product and are protected under U.S. copyright and other laws.  
 Unless in conjunction with business conducted with Jensen Precast, any use of Jensen Precast work product without express, written consent is prohibited, and recipient is prohibited from distributing any and all work product to non-approved third parties under penalty of civil action.

PROJECT:	HARBOR REVITALIZATION DANA POINT, CA		REV:
PART NUMBER:	200063012	DRAWN BY:	rasal9
CREATED:		MODIFIED:	8/31/2022
			SHEET: 1 OF 1

200063170.rpt

# STORMVAULT WITH 3-PACK STORMSAFE CARTRIDGES STORMWATER TREATMENT BMP #14

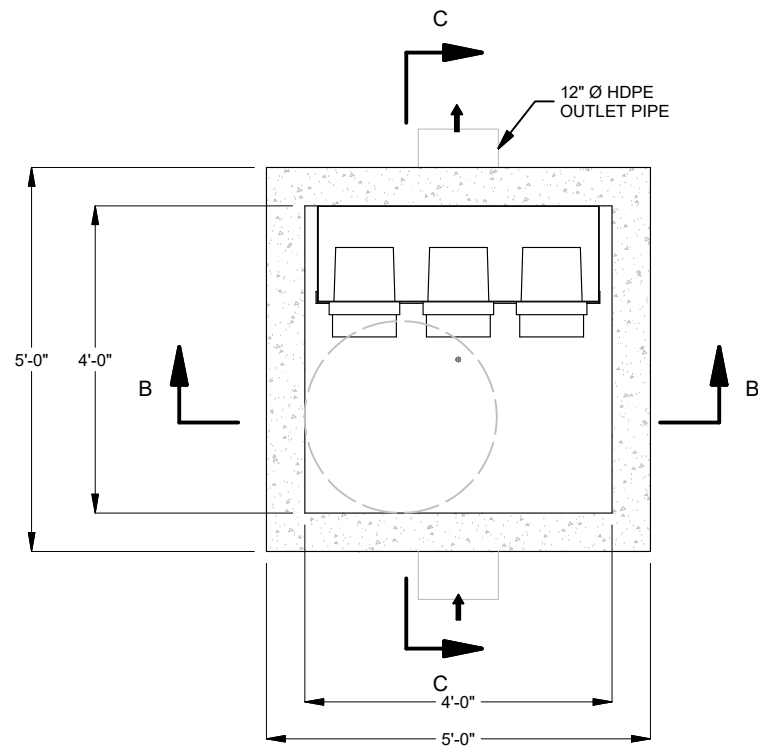

**PLAN VIEW**

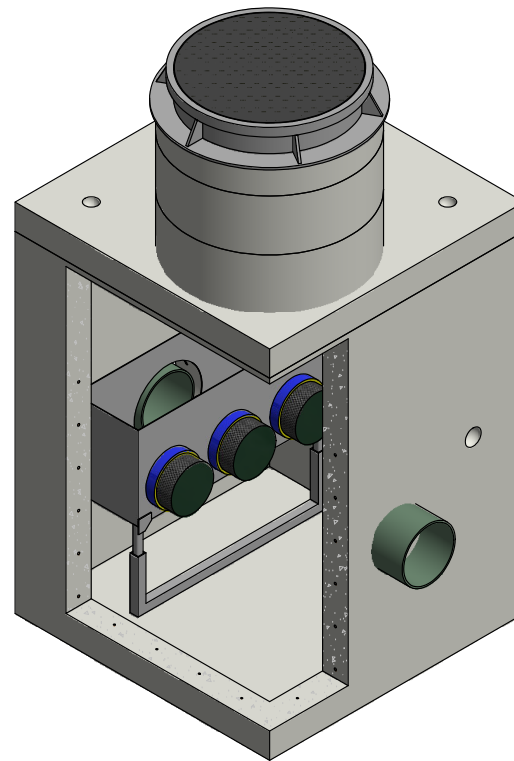

**ISO VIEW**

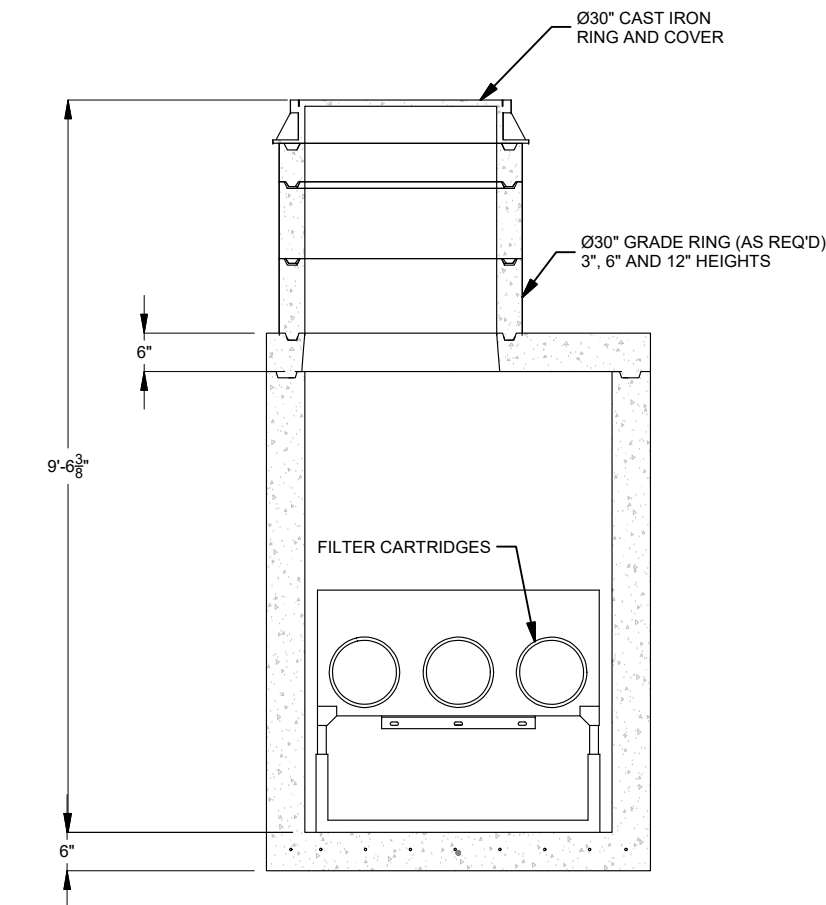

**SECTION B-B**

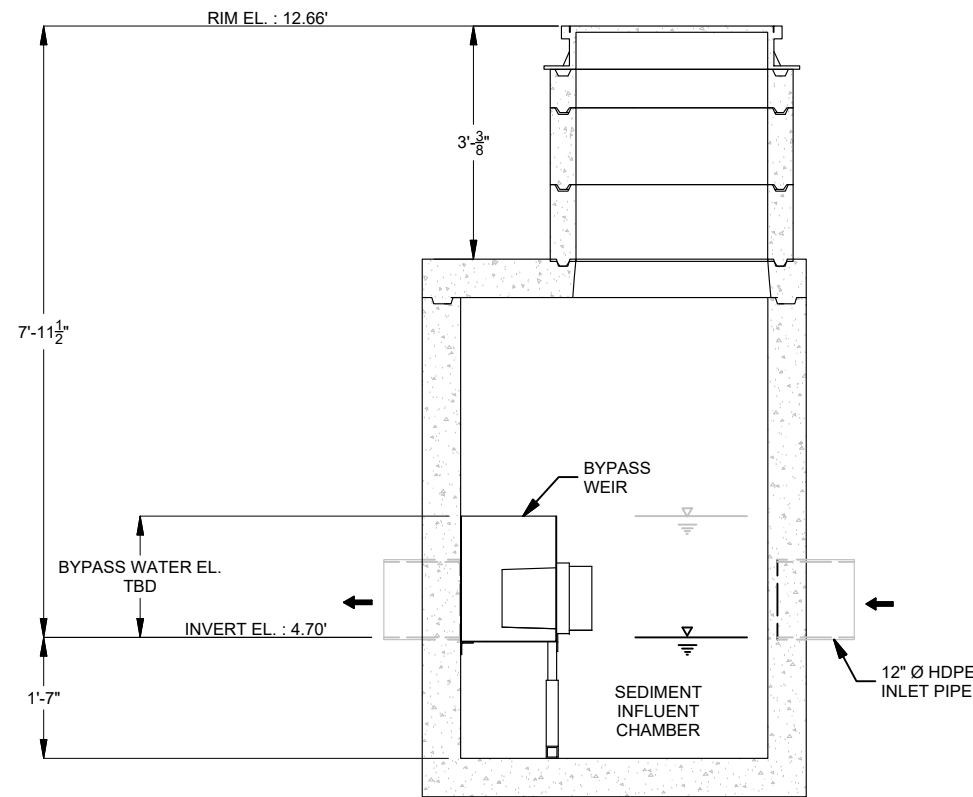

**SECTION C-C**

**HYDRAULICS AND TREATMENT:**

STORMWATER QUALITY DESIGN FLOW (SQDF)	≤ 0.245-CFS
STORM DRAIN DESIGN PEAK CONVEYANCE FLOW	0.768-CFS
RETURN FREQUENCY / PERIOD OF PEAK DESIGN CONVEYANCE FLOW	2 - YEARS

**TREATMENT PERFORMANCE NOTES:**

MEDIA FILTER SUBSTRATA	PATHOGEN CARTRIDGE
NUMBER OF CARTRIDGES	3
INDIVIDUAL CARTRIDGE ULTIMATE MAXIMUM LOADING RATE	115-GPM / CART
HYDRAULIC DRIVING HEAD	6-INCHES

THE STORMSAFE FILTER CARTRIDGE (BY FABCO) EMPLOYS A PATENTED ANTI-MICROBIAL MEDIA TO TREAT STORMWATER. THE TREATMENT PROCESS IS DESIGNED TO ACHIEVE BACTERIA REDUCTION THROUGH CELLULAR DISRUPTION, AS WELL AS BASIC SEDIMENTATION AND PHYSICAL FILTRATION OF TOTAL SUSPENDED SOLIDS (TSS) AND GROSS SOLIDS AND DEBRIS REMOVAL. THE STORMSAFE PATHOGEN CARTRIDGE ACHIEVES THE FOLLOWING EFFLUENT DISCHARGE WATER QUALITY GOALS:

- SPECIFICALLY TARGETS AND KILLS 50 TO 70% OF THE BACTERIA IN STORMWATER
- PROVEN CAPABLE OF REDUCING THE FOLLOWING TYPES OF INDICATOR BACTERIA:
  - 77% E. COLI
  - 77% FECAL COLIFORM
  - 49% ENTEROCOCCUS
- NO ATTENUATION OR DISSIPATION OF BACTERIA REMOVAL EFFICIENCY OVER TIME REGARDLESS OF TOTAL MASS LOADING
- NO TOXICITY RESIDUAL IMPACTS TO DOWNSTREAM BIOTA
- REMOVAL OF OIL AND GREASE

**DESIGN GUIDANCE NOTES:**

- FILTER CARTRIDGES SHALL BE OPEN CELL FOAM SUBSTRATA MEDIA WITH THE PATENTED CHEMICAL CHARGED COATING ON POLYMER OPEN CELL FOAM SUBSTRATA MEDIA.
- THE DEPTH OF THE POLYMER MEDIA SHALL BE NOT LESS THAN 11-INCHES IN DEPTH / THICKNESS.
- THE SPECIFIC HYDRAULIC LOADING RATE OF THE FILTRATION MEDIA SHALL BE NO MORE THAN THE VALUE SHOWN IN THE STORMSAFE FILTER TREATMENT DESIGN TABLE ABOVE.
- GROUNDWATER ELEVATION IS ASSUMED TO BE BELOW THE BOTTOM OF PRECAST STRUCTURE. CONTACT JENSEN STORMWATER SYSTEMS FOR HIGH GROUNDWATER CONDITIONS.
- FOUNDATION, SUBGRADE, AND BACKFILL TO BE DESIGNED BY OTHERS.

**GENERAL NOTES:**

- STANDARD CONFIGURATION IS SHOWN. CONTACT JENSEN STORMWATER SYSTEMS FOR CUSTOM DESIGNS, [www.jensenengineersystems.com](http://www.jensenengineersystems.com).
- PLAN VIEW TOP SLAB WITH FRAMES AND COVERS ARE NOT SHOWN FOR CLARITY.
- JENSEN STORMWATER SYSTEMS TO PROVIDE ALL MATERIALS SHOWN, UNLESS OTHERWISE NOTED.

**CONSTRUCTION / INSTALLATION NOTES:**

- CONTRACTOR TO VERIFY VERTICAL DIMENSIONS OF ALL PRECAST PIECES IN FIELD.
- VERIFY SUBBASE ELEVATION BEFORE PLACING PRECAST COMPONENTS OR BACKFILLING.
- APPLY BUTYL MASTIC AND/OR GROUT TO SEAL JOINTS OF STRUCTURE.
- APPLY LOAD TO MASTIC SEAL IN JOINTS OF VAULT/MANHOLE SECTIONS TO COMPRESS SEALANT IF NECESSARY. UNIT MUST BE WATER TIGHT, HOLDING WATER UP TO FLOWLINE INVERT (MINIMUM).
- CONTRACTOR TO GROUT SEAL INLET AND DISCHARGE PIPES TO VAULT/MANHOLE WALL.
- BLOCK AND/OR GROUT PACK BENEATH FRAMES AND COVERS TO MATCH FINISHED GRADE.

**MATERIALS:**

- ALL DIMENSIONS ARE IN FEET OR FRACTIONAL INCHES
- PRECAST MATERIALS AND MANUFACTURING METHODS SHALL CONFORM TO ASTM C-857.
- CONCRETE SHALL HAVE A MINIMUM COMPRESSIVE STRENGTH F' c = 5,000 - psi AT 28-DAYS
- THE PORTLAND CEMENT USED IN THE PRECAST SECTION SHALL MEET THE REQUIREMENTS OF TYPE II/V HIGH SULFATE RESISTANT CEMENT IN ACCORDANCE WITH ASTM CLASS M C-150
- ALL METAL WORK SHALL BE ASTM 316L MARINE GRADE STAINLESS STEEL

**LIFTING WEIGHTS:**

- HEAVIEST PICK WEIGHT IS 7,250-LBS
- JENSEN CRANE TRUCK CAN SET A MAXIMUM OF 25,000-LBS AT 15-FT OFFSET DISTANCE FROM CENTER OF CRANE TRUNNION

**MATERIAL LIST - PROVIDED WITH UNIT:**

QTY	COMPONENT DESCRIPTION	PROVIDER	INSTALLER
3	STORM SAFE PATHOGEN FILTER CARTRIDGES	JENSEN	JENSEN
AS REQ'D	30" GRADE RING	JENSEN	CONTRACTOR
1	30" CAST IRON RING AND COVER	JENSEN	CONTRACTOR

**(\*) REGIONAL MANUFACTURING DIFFERENCE:**

THESE ARE TEMPLATE SITE DESIGN DRAWINGS. JOINT ORIENTATIONS AND FINAL WALL/BASE THICKNESS VARY ACROSS JENSEN'S REGIONAL MANUFACTURING FACILITIES. CONFIRM FINAL JOINT ORIENTATION AND THICKNESS PER CONSTRUCTION SUBMITTAL DRAWINGS. ADJUST FINAL DIMENSIONS TO EXTERIOR INVERT AND SUBGRADE ELEVATION PER REGION DIFFERENCES.

200063044.rpt

**DISCLAIMERS, INCLUDING BUT NOT LIMITED TO:**

- All elevations have been provided by others, and have not been verified by Jensen Precast. Contractor to verify all dimensions and elevations in field prior to installation.
- These layout drawings are intended to show overall system design only. All concrete component thicknesses, dimensions, and joint orientations may vary across Jensen Precast's manufacturing facilities. Contractor to confirm all thicknesses, dimensions, and joint orientations prior to installation.
- System design criteria has been provided to Jensen Precast. Others are responsible for verification that system meets intended application.
- Foundation, subgrade, and backfill to be designed by others.

**JENSEN** STORMWATER SYSTEMS  
 521 DUNN CIRCLE, SPARKS, NV 89431  
[www.jensenwaterresources.com](http://www.jensenwaterresources.com)  
 (855) 468-5600

©2018 Jensen Precast - All rights reserved.  
 All materials appearing as Jensen Precast documents and the like are proprietary work product and are protected under U.S. copyright and other laws.  
 Unless in conjunction with business conducted with Jensen Precast, any use of Jensen Precast work product without express, written consent is prohibited, and recipient is prohibited from distributing any and all work product to non-approved third parties under penalty of civil action.

PROJECT:	HARBOR REVITALIZATION - BMP #14 DANA POINT, CA		REV:
PART NUMBER:	200063044	DRAWN BY:	rasal9
CREATED:		MODIFIED:	8/31/2022
			SHEET: 1 OF 1

# STORMVAULT WITH 3-PACK STORMSAFE CARTRIDGES STORMWATER TREATMENT BMP #18

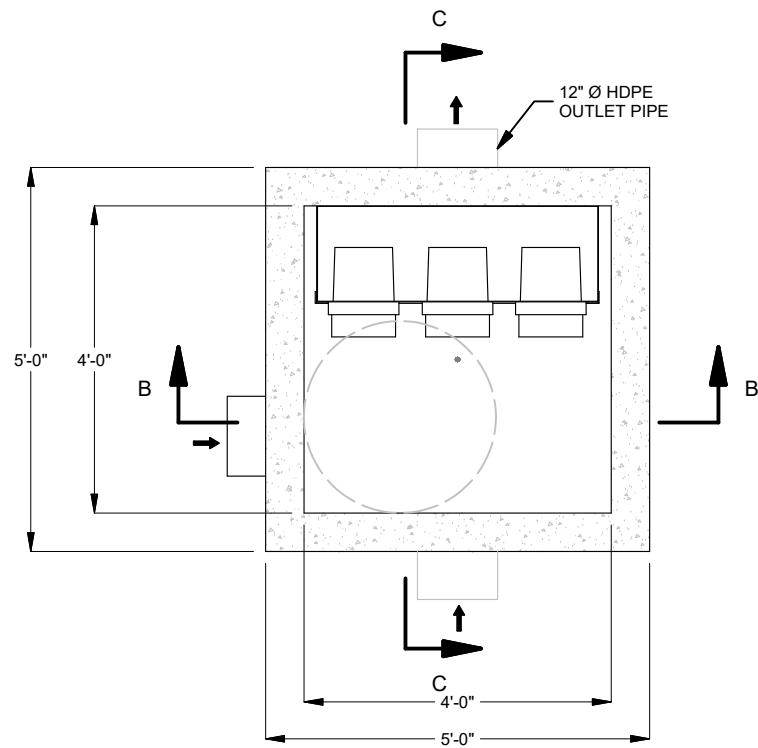

**PLAN VIEW**

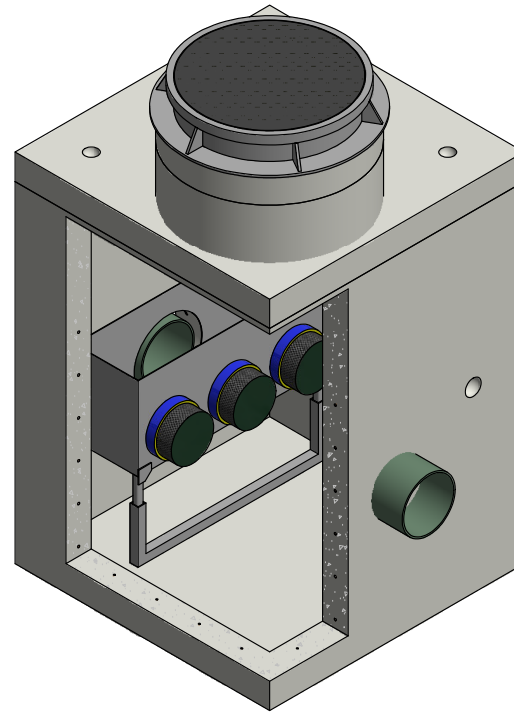

**ISO VIEW**

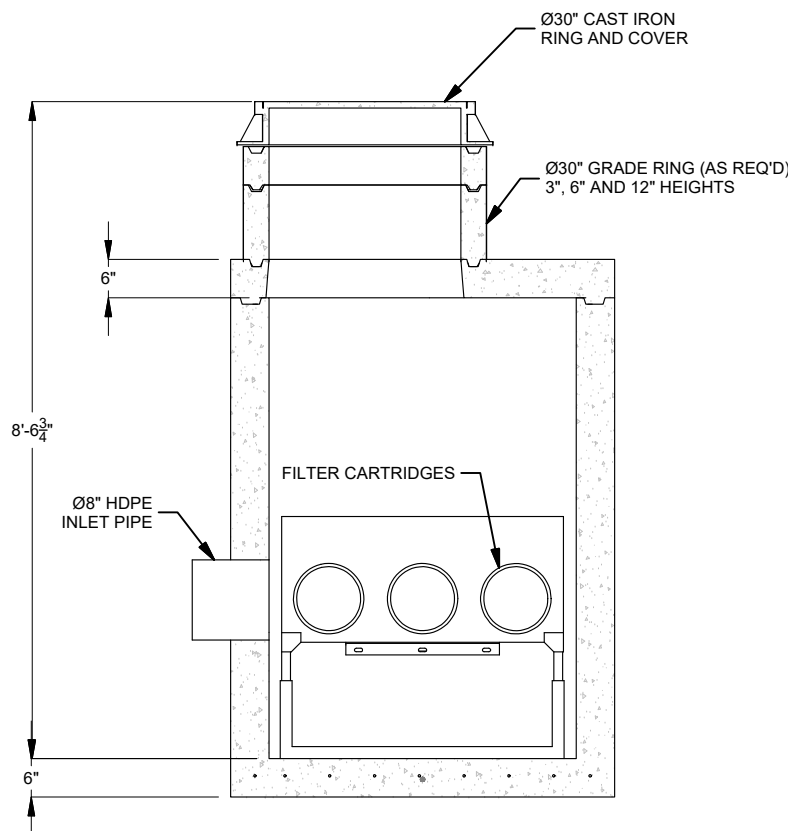

**SECTION B-B**

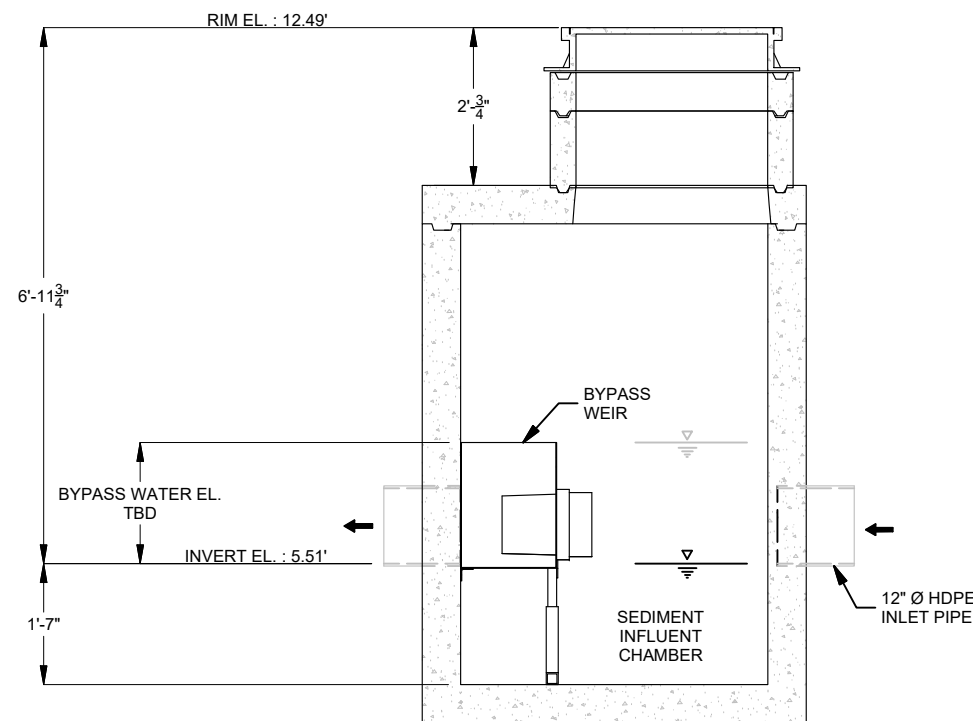

**SECTION C-C**

**HYDRAULICS AND TREATMENT:**

STORMWATER QUALITY DESIGN FLOW (SQDF)	≤ 0.217-CFS
STORM DRAIN DESIGN PEAK CONVEYANCE FLOW	0.768-CFS
RETURN FREQUENCY / PERIOD OF PEAK DESIGN CONVEYANCE FLOW	2 - YEARS

**TREATMENT PERFORMANCE NOTES:**

MEDIA FILTER SUBSTRATA	PATHOGEN CARTRIDGE
NUMBER OF CARTRIDGES	3
INDIVIDUAL CARTRIDGE ULTIMATE MAXIMUM LOADING RATE	115-GPM / CART
HYDRAULIC DRIVING HEAD	6-INCHES

THE STORMSAFE FILTER CARTRIDGE (BY FABCO) EMPLOYS A PATENTED ANTI-MICROBIAL MEDIA TO TREAT STORMWATER. THE TREATMENT PROCESS IS DESIGNED TO ACHIEVE BACTERIA REDUCTION THROUGH CELLULAR DISRUPTION, AS WELL AS BASIC SEDIMENTATION AND PHYSICAL FILTRATION OF TOTAL SUSPENDED SOLIDS (TSS) AND GROSS SOLIDS AND DEBRIS REMOVAL. THE STORMSAFE PATHOGEN CARTRIDGE ACHIEVES THE FOLLOWING EFFLUENT DISCHARGE WATER QUALITY GOALS:

- SPECIFICALLY TARGETS AND KILLS 50 TO 70% OF THE BACTERIA IN STORMWATER
- PROVEN CAPABLE OF REDUCING THE FOLLOWING TYPES OF INDICATOR BACTERIA:
  - 77% E. COLI
  - 77% FECAL COLIFORM
  - 49% ENTEROCOCCUS
- NO ATTENUATION OR DISSIPATION OF BACTERIA REMOVAL EFFICIENCY OVER TIME REGARDLESS OF TOTAL MASS LOADING
- NO TOXICITY RESIDUAL IMPACTS TO DOWNSTREAM BIOTA
- REMOVAL OF OIL AND GREASE

**DESIGN GUIDANCE NOTES:**

1. FILTER CARTRIDGES SHALL BE OPEN CELL FOAM SUBSTRATA MEDIA WITH THE PATENTED CHEMICAL CHARGED COATING ON POLYMER OPEN CELL FOAM SUBSTRATA MEDIA.
2. THE DEPTH OF THE POLYMER MEDIA SHALL BE NOT LESS THAN 11-INCHES IN DEPTH / THICKNESS.
3. THE SPECIFIC HYDRAULIC LOADING RATE OF THE FILTRATION MEDIA SHALL BE NO MORE THAN THE VALUE SHOWN IN THE STORMSAFE FILTER TREATMENT DESIGN TABLE ABOVE.
4. GROUNDWATER ELEVATION IS ASSUMED TO BE BELOW THE BOTTOM OF PRECAST STRUCTURE. CONTACT JENSEN STORMWATER SYSTEMS FOR HIGH GROUNDWATER CONDITIONS.
5. FOUNDATION, SUBGRADE, AND BACKFILL TO BE DESIGNED BY OTHERS.

**GENERAL NOTES:**

1. STANDARD CONFIGURATION IS SHOWN. CONTACT JENSEN STORMWATER SYSTEMS FOR CUSTOM DESIGNS, [www.jensenengineeredsystems.com](http://www.jensenengineeredsystems.com).
2. PLAN VIEW TOP SLAB WITH FRAMES AND COVERS ARE NOT SHOWN FOR CLARITY.
3. JENSEN STORMWATER SYSTEMS TO PROVIDE ALL MATERIALS SHOWN, UNLESS OTHERWISE NOTED.

**CONSTRUCTION / INSTALLATION NOTES:**

1. CONTRACTOR TO VERIFY VERTICAL DIMENSIONS OF ALL PRECAST PIECES IN FIELD.
2. VERIFY SUBBASE ELEVATION BEFORE PLACING PRECAST COMPONENTS OR BACKFILLING.
3. APPLY BUTYL MASTIC AND/OR GROUT TO SEAL JOINTS OF STRUCTURE.
4. APPLY LOAD TO MASTIC SEAL IN JOINTS OF VAULT/MANHOLE SECTIONS TO COMPRESS SEALANT IF NECESSARY. UNIT MUST BE WATER TIGHT, HOLDING WATER UP TO FLOWLINE INVERT (MINIMUM).
5. CONTRACTOR TO GROUT SEAL INLET AND DISCHARGE PIPES TO VAULT/MANHOLE WALL.
6. BLOCK AND/OR GROUT PACK BENEATH FRAMES AND COVERS TO MATCH FINISHED GRADE.

**MATERIALS:**

1. ALL DIMENSIONS ARE IN FEET OR FRACTIONAL INCHES
2. PRECAST MATERIALS AND MANUFACTURING METHODS SHALL CONFORM TO ASTM C-857.
3. CONCRETE SHALL HAVE A MINIMUM COMPRESSIVE STRENGTH F' c = 5,000 - psi AT 28-DAYS
4. THE PORTLAND CEMENT USED IN THE PRECAST SECTION SHALL MEET THE REQUIREMENTS OF TYPE II/V HIGH SULFATE RESISTANT CEMENT IN ACCORDANCE WITH ASTM CLASS M C-150
5. ALL METAL WORK SHALL BE ASTM 316L MARINE GRADE STAINLESS STEEL

**LIFTING WEIGHTS:**

1. HEAVIEST PICK WEIGHT IS 7,250-LBS
2. JENSEN CRANE TRUCK CAN SET A MAXIMUM OF 25,000-LBS AT 15-FT OFFSET DISTANCE FROM CENTER OF CRANE TRUNNION

**MATERIAL LIST - PROVIDED WITH UNIT:**

QTY	COMPONENT DESCRIPTION	PROVIDER	INSTALLER
3	STORM SAFE PATHOGEN FILTER CARTRIDGES	JENSEN	JENSEN
AS REQ'D	30" GRADE RING	JENSEN	CONTRACTOR
1	30" CAST IRON RING AND COVER	JENSEN	CONTRACTOR

**(\* REGIONAL MANUFACTURING DIFFERENCE:**

THESE ARE TEMPLATE SITE DESIGN DRAWINGS. JOINT ORIENTATIONS AND FINAL WALL/BASE THICKNESS VARY ACROSS JENSEN'S REGIONAL MANUFACTURING FACILITIES. CONFIRM FINAL JOINT ORIENTATION AND THICKNESS PER CONSTRUCTION SUBMITTAL DRAWINGS. ADJUST FINAL DIMENSIONS TO EXTERIOR INVERT AND SUBGRADE ELEVATION PER REGION DIFFERENCES.

200063053.rdw

**DISCLAIMERS, INCLUDING BUT NOT LIMITED TO:**

- 1.) All elevations have been provided by others, and have not been verified by Jensen Precast. Contractor to verify all dimensions and elevations in field prior to installation.
- 2.) These layout drawings are intended to show overall system design only. All concrete component thicknesses, dimensions, and joint orientations may vary across Jensen Precast's manufacturing facilities. Contractor to confirm all thicknesses, dimensions, and joint orientations prior to installation.
- 3.) System design criteria has been provided to Jensen Precast. Others are responsible for verification that system meets intended application.
- 4.) Foundation, subgrade, and backfill to be designed by others.

**JENSEN** STORMWATER SYSTEMS  
521 DUNN CIRCLE, SPARKS, NV 89431  
[www.jensenwaterresources.com](http://www.jensenwaterresources.com)  
(855) 468-5600

©2018 Jensen Precast - All rights reserved.  
All materials appearing as Jensen Precast documents and the like are proprietary work product and are protected under U.S. copyright and other laws.  
Unless in conjunction with business conducted with Jensen Precast, any use of Jensen Precast work product without express, written consent is prohibited, and recipient is prohibited from distributing any and all work product to non-approved third parties under penalty of civil action.

PROJECT:	HARBOR REVITALIZATION - BMP #18 DANA POINT, CA		REV:
PART NUMBER:	200063053	DRAWN BY:	rasal9
CREATED:		MODIFIED:	8/31/2022
			SHEET: 1 OF 1

# STORMVAULT WITH 1-PACK STORMSAFE CARTRIDGES STORMWATER TREATMENT BMP #19

## SYSTEM AND TREATMENT FLOW DESIGN:

STORMWATER QUALITY DESIGN FLOW (SQDF)	≤ 0.217-CFS
STORM DRAIN DESIGN PEAK CONVEYANCE FLOW	0.768-CFS
RETURN FREQUENCY / PERIOD OF PEAK DESIGN CONVEYANCE FLOW	2 - YEARS

## STORMSAFE FILTER TREATMENT DESIGN:

MEDIA FILTER SUBSTRATA	PATHOGEN CARTRIDGE
NUMBER OF CARTRIDGES	1
INDIVIDUAL CARTRIDGE ULTIMATE MAXIMUM LOADING RATE	115-GPM / CART
HYDRAULIC DRIVING HEAD	6-INCHES

## STORMWATER FILTRATION TREATMENT UNIT (SWFTU) NOTES:

THE STORMSAFE FILTER EMPLOYS THE PATENTED ANTIMICROBIAL MEDIA TO TREAT STORMWATER BY FABCO. TREATMENT PROCESS IS DESIGNED TO ACHIEVE BACTERIA REDUCTION THROUGH PHYSICAL CELLULAR DISRUPTION IN ADDITION TO BASIC SEDIMENTATION, PHYSICAL FILTRATION OF TOTAL SUSPENDED SOLIDS (TSS), AND GROSS SOLIDS AND DEBRIS. THE STORMSAFE PATHOGEN CARTRIDGE ACHIEVES THE FOLLOWING EFFLUENT DISCHARGE WATER QUALITY GOALS OF:

- SPECIFICALLY TARGETS AND KILLS 50 TO 70% OF THE BACTERIA IN STORMWATER
- PROVEN CAPABLE OF REDUCING THE FOLLOWING TYPES OF INDICATOR BACTERIA:
  - 77% E.Coli
  - 77% FECAL COLIFORM
  - 49% ENTEROCOCCUS
- NO ATTENUATION, DISSIPATION OF BACTERIA REMOVAL EFFICIENCY OVER TIME REGARDLESS OF TOTAL MASS LOADING
- NO TOXICITY RESIDUAL IMPACTS TO DOWN STREAM BIOTA
- REMOVAL OF OIL AND GREASE

## MEDIA FILTRATION PROCESS SPECIFICATIONS:

- FILTER CARTRIDGES SHALL BE OPEN CELL FOAM SUBSTRATA MEDIA WITH THE PATENTED CHEMICAL CHARGED COATING ON POLYMER OPEN CELL FOAM SUBSTRATA MEDIA.
- THE DEPTH OF THE POLYMER MEDIA SHALL BE NOW LESS THAN 11-INCHES IN DEPTH / THICKNESS.
- THE SPECIFIC HYDRAULIC LOADING RATE OF THE FILTRATION MEDIA SHALL BE NO MORE THAN 115-GPM/CARTRIDGE.

## CONSTRUCTION NOTES:

- CONTRACTOR TO VERIFY VERTICAL DIMENSIONS OF ALL PRECAST PIECES IN FIELD
- VERIFY SUBBASE ELEVATION BEFORE PLACING PRECAST COMPONENTS OR BACKFILLING.
- APPLY BUTYL MASTIC AND/OR GROUT TO SEAL JOINTS OF STRUCTURE.
- APPLY LOAD TO MASTIC SEAL IN JOINTS OF VAULT/MANHOLE SECTIONS TO COMPRESS SEALANT IF NECESSARY. UNIT MUST BE WATER TIGHT, HOLDING WATER UP TO FLOWLINE INVERT (MINIMUM).
- CONTRACTOR TO GROUT SEAL INLET AND DISCHARGE PIPES TO VAULT/MANHOLE WALL
- ALL INTERNAL COMPONENTS INSTALLED BY MANUFACTURER
- BLOCK AND/OR GROUT PACK BENEATH FRAMES AND COVERS TO MATCH FINISHED GRADE.

## MATERIALS:

- FINAL DIMENSIONS OF PROJECT SPECIFIC MANUFACTURING VARIES WITH LOCAL PRE-CASTING CAPACITIES AS WELL AS PER SITE SPECIFIC STRUCTURAL DESIGN TO MEET INSTALLATION, APPLICATION DEMANDS.
- ALL DIMENSIONS ARE IN DECIMAL INCHES
- PRECAST MATERIALS AND MANUFACTURING METHODS SHALL CONFORM TO ASTM C-857 AND ASSHTO LOADING METHOD
- CONCRETE SHALL HAVE A MINIMUM COMPRESSIVE STRENGTH  $f'c = 5,000$  - psi AT 28-DAYS
- THE PORTLAND CEMENT USED IN THE PRECAST SECTION SHALL MEET THE REQUIREMENTS OF TYPE II/V HIGH SULFATE RESISTANT
- BASIN (PLASTIC) SHALL BE POLYPROPYLENE COPOLYMER
- ALUMINUM ALLOY SHALL BE ASTM 5052-H32
- STAINLESS STEEL SHALL BE ASTM 316L

## MATERIAL LIST - PROVIDED WITH UNIT:

QTY	COMPONENT DESCRIPTION	PROVIDER	INSTALLER
1	STORMSAFE PATHOGEN FILTER CARTRIDGES	JENSEN	CONTRACTOR
1	24" SQUARE CAST IRON FRAME AND COVER	JENSEN	CONTRACTOR

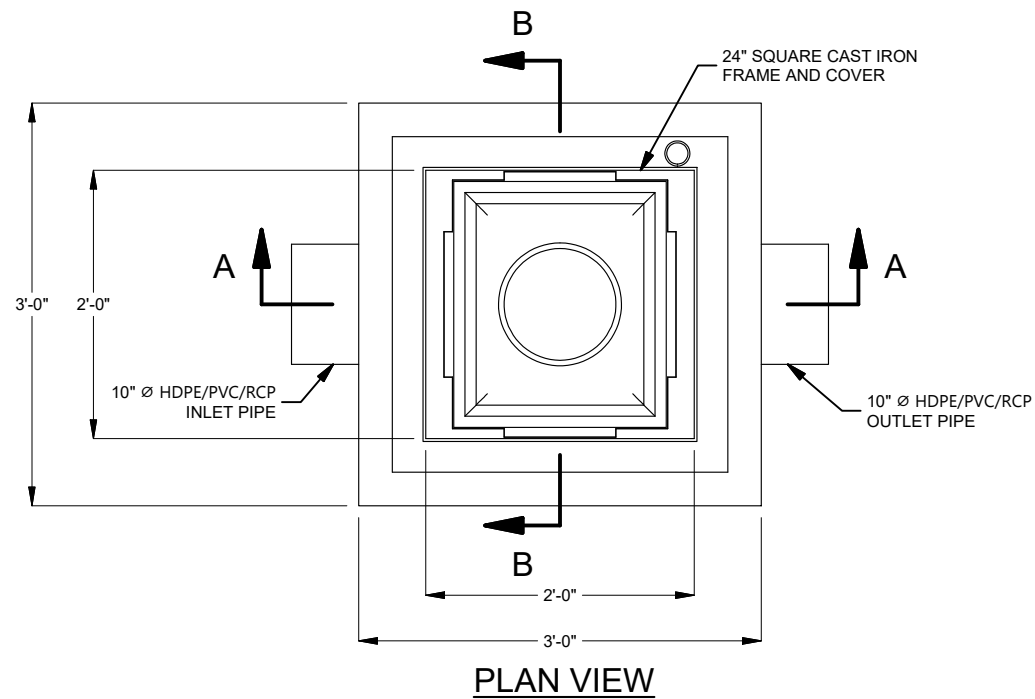

PLAN VIEW

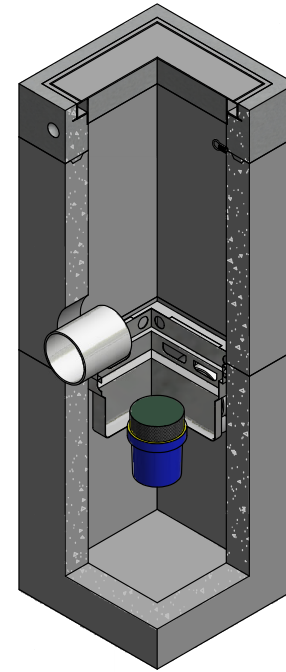

ISO VIEW

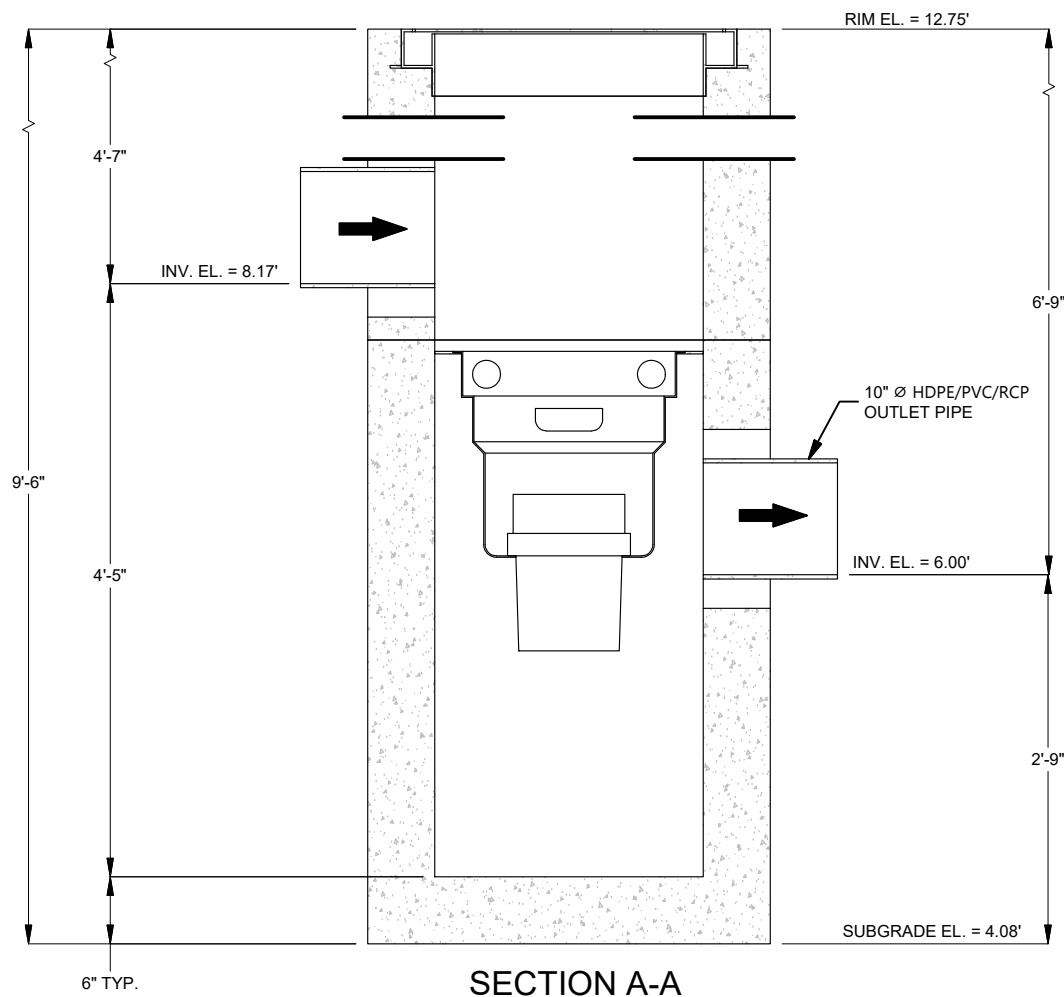

SECTION A-A

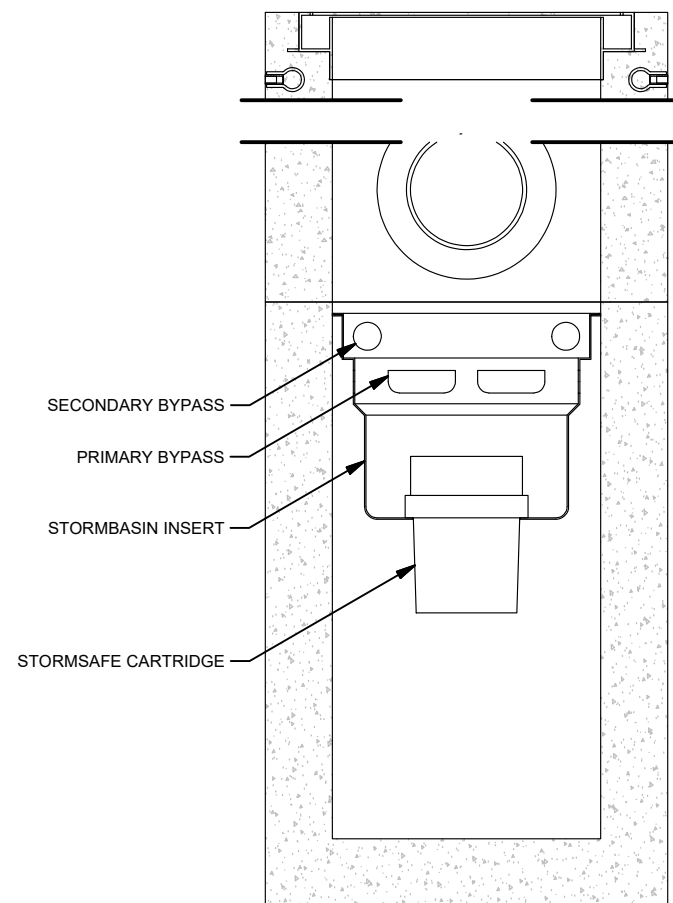

SECTION B-B

### DISCLAIMERS, INCLUDING BUT NOT LIMITED TO:

- All elevations have been provided by others, and have not been verified by Jensen Precast. Contractor to verify all dimensions and elevations in field prior to installation.
- These layout drawings are intended to show overall system design only. All concrete component thicknesses, dimensions, and joint orientations may vary across Jensen Precast's manufacturing facilities. Contractor to confirm all thicknesses, dimensions, and joint orientations prior to installation.
- System design criteria has been provided to Jensen Precast. Others are responsible for verification that system meets intended application.
- Foundation, subgrade, and backfill to be designed by others.

©2018 Jensen Precast - All rights reserved. All materials appearing as Jensen Precast documents and the like are proprietary work product and are protected under U.S. copyright and other laws. Unless in conjunction with business conducted with Jensen Precast, any use of Jensen Precast work product without express, written consent is prohibited, and recipient is prohibited from distributing any and all work product to non-approved third parties under penalty of civil action.



521 DUNN CIRCLE, SPARKS, NV 89431  
www.jensenwaterresources.com  
(855) 468-5600

### MODEL:

24X24 DROP INLET WITH  
STORMSAFE FILTER CARTRIDGE

### PROJECT:

HARBOR REVITALIZATION - BMP #19

DANA POINT, CA

### PART NUMBER:

200063022

### CREATED:

### DRAWN BY:

rasal9

### MODIFIED:

8/31/2022

### REV:

### SHEET:

1 of 1

200063020.dwg

# MWS Linear 2.0 HGL Sizing Calculations



MWS MODEL SIZE	WETLAND PERMITTER LENGTH	LOADING RATE GPM/SF	HGL HEIGHT																																
			SHALLOW MODELS																													STANDARD HEIGHT MODEL	HIGH CAPACITY MODELS		
			1.4	1.5	1.6	1.7	1.8	1.9	2.0	2.1	2.2	2.3	2.4	2.5	2.6	2.7	2.8	2.9	3.0	3.1	3.2	3.3	3.4	3.5	3.6	3.65	3.70	3.75	3.80	3.85	3.90		3.95		
MWS-L-4-4	6.70	1.0	0.022	0.023	0.025	0.026	0.028	0.029	0.031	0.032	0.034	0.035	0.037	0.038	0.040	0.042	0.043	0.045	0.046	0.048	0.049	0.051	0.052	0.054	0.055	0.056	0.057	0.058	0.058	0.059	0.060	0.061			
MWS-L-4-6	9.10	1.0	0.029	0.031	0.033	0.036	0.038	0.040	0.042	0.044	0.046	0.048	0.050	0.052	0.054	0.056	0.058	0.061	0.063	0.065	0.067	0.069	0.071	0.073	0.075	0.076	0.077	0.078	0.079	0.080	0.081	0.082			
MWS-L-4-8	14.80	1.0	0.048	0.051	0.054	0.058	0.061	0.065	0.068	0.071	0.075	0.078	0.082	0.085	0.088	0.092	0.095	0.099	0.102	0.105	0.109	0.112	0.115	0.119	0.122	0.124	0.126	0.127	0.129	0.131	0.132	0.134			
MWS-L-4-13	18.40	1.0	0.059	0.063	0.068	0.072	0.076	0.080	0.084	0.089	0.093	0.097	0.101	0.106	0.110	0.114	0.118	0.122	0.127	0.131	0.135	0.139	0.144	0.148	0.152	0.154	0.156	0.158	0.160	0.163	0.165	0.167			
MWS-L-4-15	22.40	1.0	0.072	0.077	0.082	0.087	0.093	0.098	0.103	0.108	0.113	0.118	0.123	0.129	0.134	0.139	0.144	0.149	0.154	0.159	0.165	0.170	0.175	0.180	0.185	0.188	0.190	0.193	0.195	0.198	0.200	0.203			
MWS-L-4-17	26.40	1.0	0.085	0.091	0.097	0.103	0.109	0.115	0.121	0.127	0.133	0.139	0.145	0.151	0.158	0.164	0.170	0.176	0.182	0.188	0.194	0.200	0.206	0.212	0.218	0.221	0.224	0.227	0.230	0.233	0.236	0.239			
MWS-L-4-19	30.40	1.0	0.098	0.105	0.112	0.119	0.126	0.133	0.140	0.147	0.153	0.160	0.167	0.174	0.181	0.188	0.195	0.202	0.209	0.216	0.223	0.230	0.237	0.244	0.251	0.255	0.258	0.262	0.265	0.269	0.272	0.276			
MWS-L-4-21	34.40	1.0	0.111	0.118	0.126	0.134	0.142	0.150	0.158	0.166	0.174	0.182	0.189	0.197	0.205	0.213	0.221	0.229	0.237	0.245	0.253	0.261	0.268	0.276	0.284	0.288	0.292	0.296	0.300	0.304	0.308	0.312			
MWS-L-8-12	44.40	1.0	0.143	0.153	0.163	0.173	0.183	0.194	0.204	0.214	0.224	0.234	0.245	0.255	0.265	0.275	0.285	0.296	0.306	0.316	0.326	0.336	0.346	0.357	0.367	0.372	0.377	0.382	0.387	0.392	0.397	0.402			
MWS-L-8-16	59.20	1.0	0.190	0.204	0.217	0.231	0.245	0.258	0.272	0.285	0.299	0.312	0.326	0.340	0.353	0.367	0.380	0.394	0.408	0.421	0.435	0.448	0.462	0.476	0.489	0.496	0.503	0.509	0.516	0.523	0.530	0.537			

## Dana Point Harbor - Commercial Core Retail Area

### DMA Summary

BMP No.	Area ID	Time of Concentration (min)	Design Intensity 80% capture efficiency (in/hr)	Area (ac)	Percent Impervious	Runoff Coefficient	Q80% (cfs)	Qdesign (cfs)	Q Treatment Capacity (cfs)	BMP Model
<b>OUTFALL 3</b>										
<b>STORM DRAIN LATERAL LINE C1</b>										
No. 1	C1.1	5.42	0.26	0.30	0.943	0.858	0.07	0.100	0.115	MWS-L-4-8-V (Dvert)
No. 2	C1.2	5.63	0.26	0.70	0.787	0.740	0.13	0.202	0.237	MWS-L-4-19-V (Dvert)
No. 3	C1.3	5.00	0.26	0.06	0.868	0.801	0.01	0.019	0.052	MWS-L-4-4-V (Dvert)
				<b>1.06</b>						
<b>STORM DRAIN LATERAL LINE C3</b>										
No. 4	C3.2	5.86	0.26	1.43	0.893	0.820	0.30	0.457	0.462	MWS-L-8-16-V (Dvert) HC=3.6
No. 5	C3.3	6.07	0.26	0.20	0.976	0.882	0.05	0.069	0.073	MWS-L-4-6-C
No. 6	C3.4	6.14	0.26	0.70	0.966	0.874	0.16	0.239	0.236	MWS-L-4-17-V (Dvert)
No. 7	C3.5	5.00	0.28	0.28	0.984	0.888	0.07	0.104	0.115	MWS-L-4-8-C
No. 8	C3.6	5.00	0.26	0.23	0.950	0.862	0.05	0.077	0.115	MWS-L-4-8-C
No. 9	C3.7	5.00	0.26	0.36	0.844	0.783	0.07	0.110	0.148	MWS-L-4-13-V (Dvert)
No. 9	C3.8	5.00	0.26	0.05	0.958	0.869	0.01	0.017		
No. 9	C3.9	5.00	0.26	0.07	0.898	0.824	0.01	0.022		
				<b>3.32</b>						
No. 14	C-5.1	5.37	0.26	0.81	0.833	0.775	0.16	0.245	0.768	StormSafe Filter (3 Pack)
No. 13	C-5.2	5.37	0.26	0.73	0.869	0.802	0.15	0.228	0.768	StormSafe Filter (3 Pack)
				<b>1.54</b>						
<b>STORM DRAIN LATERAL LINE C4</b>										
No. 10	C4.1	6.75	0.26	0.89	0.813	0.760	0.18	0.264	0.346	MWS-L-8-12-V (Dvert)
No. 11	C4.2	5.00	0.26	0.57	0.860	0.795	0.12	0.177	0.206	MWS-L-4-17-V (Dvert)
<b>OUTFALL 4</b>										
<b>STORM DRAIN LATERAL LINE E</b>										
No. 12	D-1	5.00	0.26	3.01	0.899	0.824	0.64	0.967	2.560	StormSafe Filter (10 Pack)
<b>OUTFALL 5</b>										
<b>STORM DRAIN LATERAL LINE D</b>										
No. 15	E-1	5.00	0.26	0.22	0.991	0.894	0.05	0.077	0.115	MWS-L-4-8-V (Dvert)
No. 16	E-2	5.00	0.26	0.27	0.837	0.778	0.05	0.082	0.147	MWS-L-6-8 ( internal bypass = 0.98 cfs)
No. 16	E-3	5.00	0.26	0.08	0.679	0.659	0.01	0.021		
No. 16	E-4	5.00	0.26	0.08	0.909	0.832	0.02	0.026		
No. 17	E-5	5.00	0.26	0.47	0.929	0.847	0.10	0.155	0.155	MWS-L-6-8 (Dvert)
No. 18	E-6	5.00	0.26	0.68	0.890	0.817	0.14	0.217	0.768	StormSafe Filter (3 Pack)
No. 19	E-7	5.00	0.26	0.21	0.832	0.774	0.04	0.063	0.256	StormSafe Filter (1 Pack)

# **Attachment F: Proprietary BMP Information**

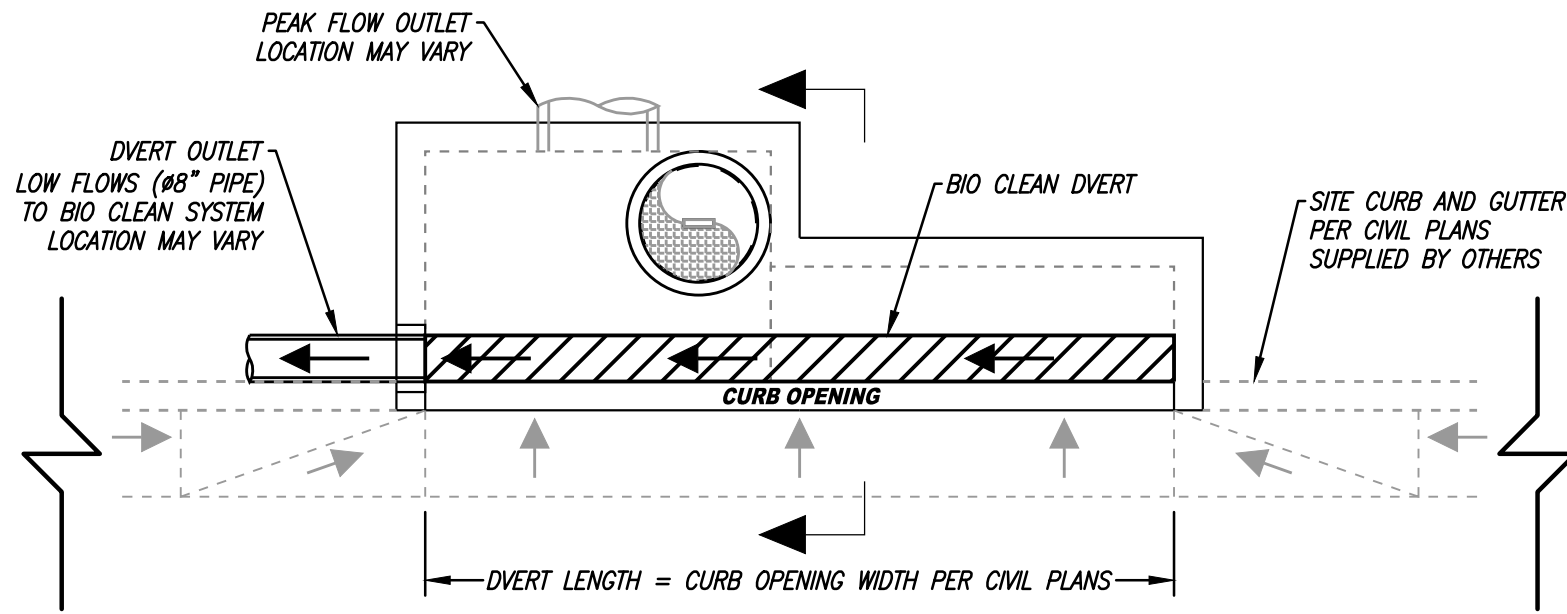

**PLAN VIEW**

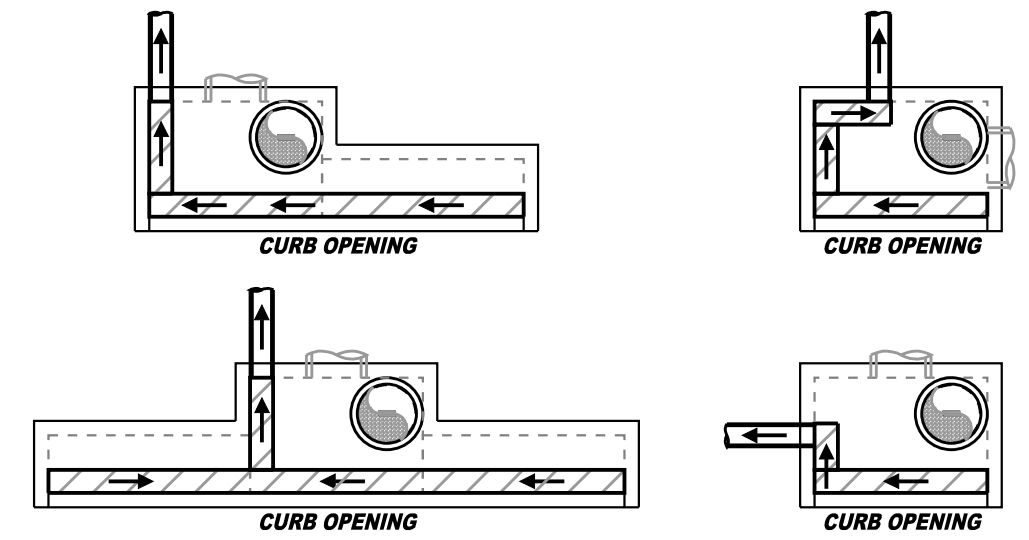

**ALTERNATE CONFIGURATIONS**  
CONTACT BIO CLEAN FOR ADDITIONAL CUSTOM CONFIGURATIONS

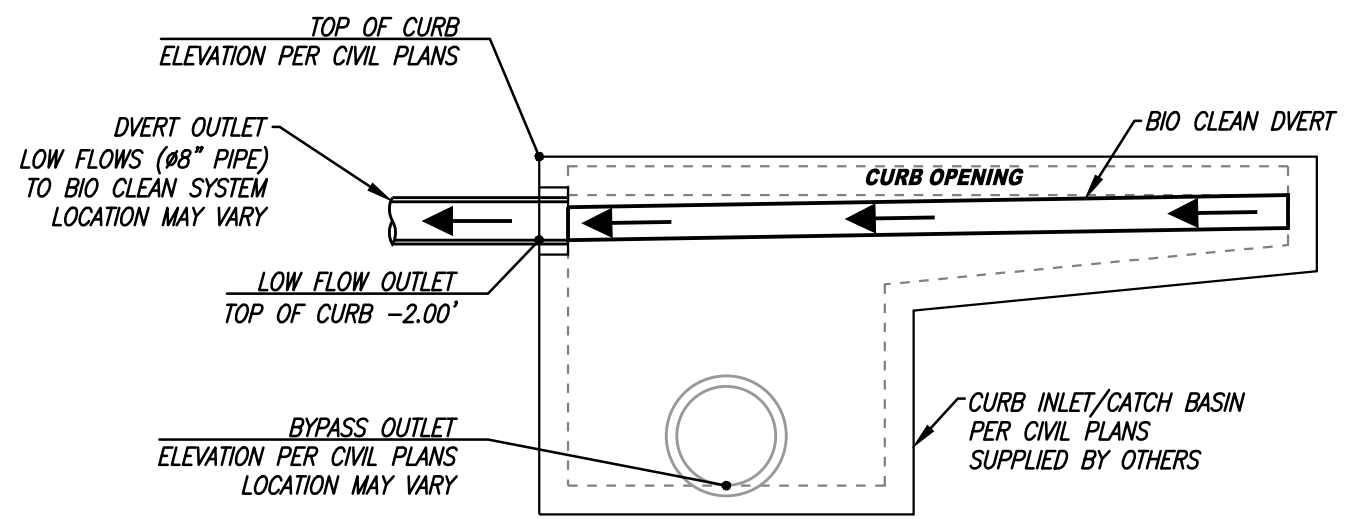

**ELEVATION VIEW**

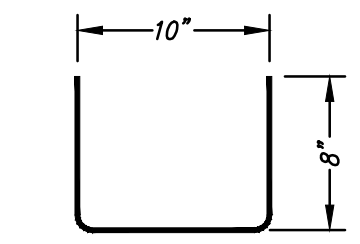

**DVERT END VIEW**

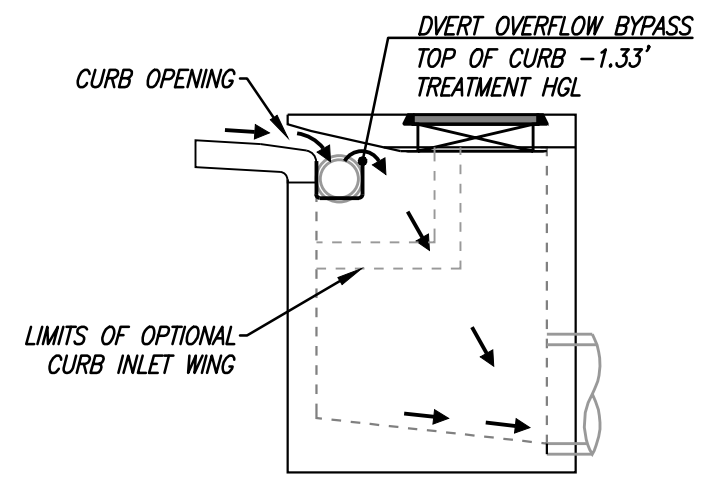

**SECTION VIEW**

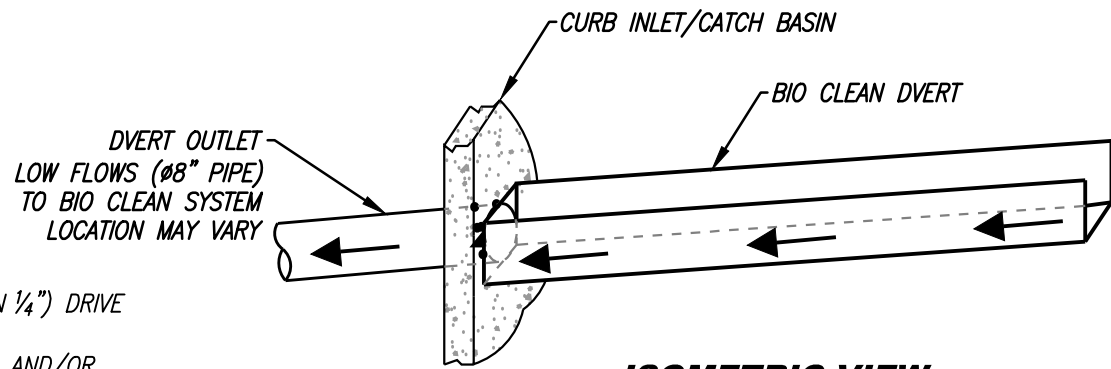

**ISOMETRIC VIEW**

**INSTALLATION NOTES**

1. DVERT TO BE CONNECTED TO CONCRETE BELOW CURB OPENING USING 316 STAINLESS STEEL (MIN 1/4") DRIVE PIN ANCHORS SPACED 12" ON CENTER AND 316 STAINLESS STEEL RIVETS (MIN 3/16").
2. ALL SEAMS BETWEEN DVERT AND CONCRETE SHALL BE FILLED WITH WATERTIGHT CONCRETE FILLER AND/OR SILICONE SEALANT.
3. CONTRACTOR TO SUPPLY AND INSTALL ALL EXTERNAL CONNECTING PIPES. ALL PIPES MUST BE FLUSH WITH INSIDE SURFACE OF CONCRETE. (PIPES CANNOT INTRUDE BEYOND FLUSH). INVERT OF OUTFLOW PIPE MUST BE FLUSH WITH THE FLOWLINE OF THE DVERT. ALL PIPES SHALL BE SEALED WATER TIGHT PER MANUFACTURERS STANDARD CONNECTION DETAIL.
4. CONTRACTOR RESPONSIBLE FOR CONTACTING BIO CLEAN FOR ACTIVATION OF UNIT. MANUFACTURES WARRANTY IS VOID WITH OUT PROPER ACTIVATION BY A BIO CLEAN REPRESENTATIVE.

MAXIMUM LOW FLOW DIVERSION (CFS)	0.74
LOW FLOW OUTLET PIPE SIZE (INCHES)	ø8"
STATIC HEAD (INCHES)	8"
SAFETY FACTOR	2

PROPRIETARY AND CONFIDENTIAL:  
THE INFORMATION CONTAINED IN THIS DOCUMENT IS THE SOLE PROPERTY OF FORTERRA AND ITS COMPANIES. THIS DOCUMENT, NOR ANY PART THEREOF, MAY BE USED, REPRODUCED OR MODIFIED IN ANY MANNER WITH OUT THE WRITTEN CONSENT OF FORTERRA.



**DVERT DVT-10-8**  
**MODULAR TROUGH DIVERSION SYSTEM**  
**STANDARD DETAIL**

4/4/18 HAYDEN

# StormSafe Vault

The StormSafe applies Fabco's proprietary filter cartridge technology in a vault configuration for centralized treatment. StormSafe can be used as a standalone treatment device or in series with other manufactured or land-based (green infrastructure) treatment systems.

Relative to other vault systems, the StormSafe is designed to provide a highly effective treatment solution within a small foot print for treatment flow rates from 4 cartridge systems (1cfs) up to 40 cartridge systems (10cfs) and beyond. Stormsafe is ideal for small parking areas, storage areas that have high concentrations of heavy metals, or maintenance facilities that generate oils and grease loads.



## Performance Specifications

- Individual cartridge flow rates of 0.1 to 0.5 CFS
- Meets and exceeds typical performance requirements for TSS (80%), TP (50%) and NO3 (40%)
- Inline or offline configuration
- Compatible with subsurface infiltration or storage designs

## Features/Benefits

1. Inlet bay
2. Sediment forebay traps sediments and debris before filter
3. Oil/Water/Debris separator retains coarse debris in the sediment chamber
4. Filter chamber utilizes multiple filter cartridges to provide effective treatment up to the rated flow rate
5. Separate overflow provides a hydraulic bypass
6. Outlet bay

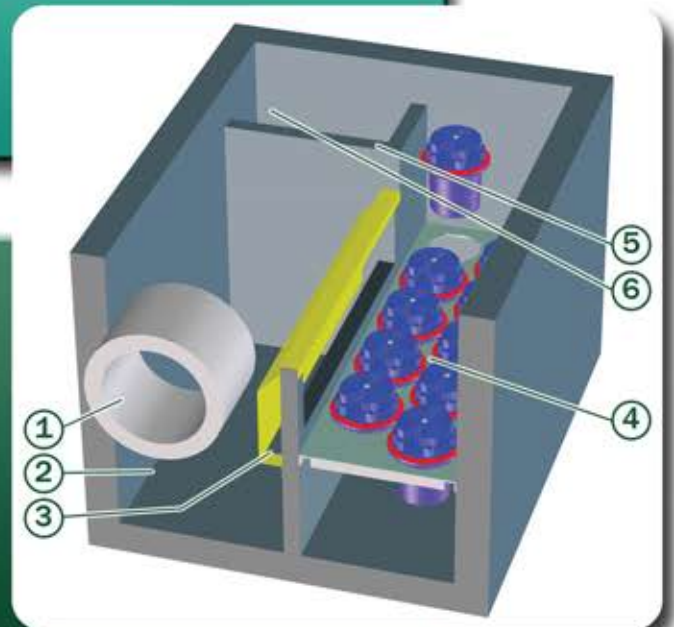

Application	Regulatory Issue	Target Pollutants
New Residential, Commercial	Municipal Stormwater Permit	Sediment, O&G, Nutrients
Fuel/Oil Storage and Handling Facilities	EPA SPCC (Spill Control Rule)	Hydrocarbons, Oily Sediments
Scrap Metal, Solid Waste, Power Plants	Industrial Multi-Sector General Permit	Solids, Hydrocarbons, Metals



# StormSafe 4C

## Storm water Filtration Chamber

# Inspection And Maintenance Guide

### Important:

- Inspection and maintenance to be performed by qualified personnel only.
- Helical filter replacement may require personnel properly trained for confined space activity in accordance with local and OSHA regulations.

66 Central Ave • Farmingdale New York 11735  
Tel: (631) 393-6024 • Fax: (631) 501-5528 • Web: [www.fabco-industries.com](http://www.fabco-industries.com)

## Inspection and Cleaning Overview

The StormSafe-4C, like any other storm water remediation device, requires regular maintenance intervals to remain effective as a storm water filter. Since maintenance requirements and frequency are dependent on the pollutant load characteristics of each site, Fabco recommends a regular inspection and maintenance regime to maintain peak performance of the cartridge filters. As required, both the influent and effluent chambers should be cleaned of any collected oil, trash, debris and sediment that may inhibit filter performance.

## Recommended Cleaning Frequency

Site conditions will determine the required cleaning frequency to maintain peak performance of the StormSafe-4C treatment chamber. There is no universal rule to predict the optimal cleanout cycle for storm water filter systems; however locations with stabilized surface conditions will require less frequent cleaning than areas exposed to erosion or construction. Over a short period of time, regular inspection by maintenance personnel will dictate the appropriate cleaning frequency. For new installations, Fabco recommends at least two (2) inspections per year. Additional inspections are recommended following major rain events. Cleaning and filter replacement should be "as needed" based on these inspections. Fabco recommends an initial filter replacement frequency of once per year until sufficient historical data predicts otherwise.

## In Case of Spills

In the event of a spill, all inspection and cleaning operations should be aborted until trained HAZMAT personnel secure the jobsite.

## Included Reference Material

StormSafe-4C Detail (Figure 1), Maintenance Log Sheet

## Visual Inspection Procedure

Inspection and cleaning should be performed only after NO rainfall for at least 24 hours.  
If working in the street, wear proper safety equipment and follow the local road safety rules & regulations.  
Begin by removing both the 36" manhole access cover located over the influent and effluent chambers of the StormSafe-4C. Allow several minutes for the system to vent.  
**CAUTION:** Grates are extremely heavy. Some type of lifting mechanism is high recommended.

---

Visually inspect both chambers for heavy sediment, trash and debris loading that may limit or prevent water flow into the filter housing. A battery powered flashlight or droplight is recommended for thorough inspection.  
Some telltale signs that cleaning or filter replacement is necessary are as follows:  
Waterline marks less than 12-in below the top of the bypass weir.  
Water level differential between the influent chamber and effluent chamber.  
Obvious heavy loading of leaves, sticks or construction debris.  
Record observations and comments on the maintenance log sheet. In addition, the use of digital photographs and/or sketches may be warranted to maintain the most accurate historical records.

## Cleaning and Filter Replacement

If cleaning or replacing a filter is deemed necessary, the following procedure is recommended:

1. Secure the worksite with the appropriate safety equipment in accordance with local and OSHA regulations.
2. Remove the 36" manhole access cover located over the influent and effluent chambers of the StormSafe-4C. Allow several minutes for the chambers to vent.
3. Perform an internal and external visual inspection of the vault's general condition including the access manhole cover and casting, as well as any exposed concrete surfaces. Record any visual anomalies such as cracks, gouges, hollows, excess wear and settling.
4. Without entering the vault, both the influent and effluent chambers can be cleaned using a typical vacuum truck or similar vacuum equipment with sufficient storage capacity.
5. Both the influent and effluent chambers are designed to accommodate standard suction hoses typical to vacuum equipment. Thoroughly vacuum liquids, debris sediment from both chambers.
6. If filter replacement is deemed unnecessary, reinstall the 36" manhole access cover. Clean the jobsite as necessary and record pertinent information on the attached "Maintenance Log Sheet" to complete the job.
7. If filter replacement is deemed necessary, vault entry is required and OSHA rules for confined space entry may be required. Check local regulations and proceed accordingly.
8. Removal of the filters is done from the influent chamber. Due to possible slippery floor conditions, care should be taken to avoid falls.
9. Use a ladder if necessary, enter the influent chamber and start by twisting and lifting one of the four cartridge filters in a **counter-clockwise** direction.
10. Repeat until all four filters have been removed, proceed to inspect and clean the cartridge openings to ensure correct fit for the new set of cartridge filters.

## Disposal

All removed water, oils, sediment, debris, trash and other accumulates collected in the StormSafe must be handled and disposed of in accordance with local, state and federal regulations.

Disposal considerations must be part of a well-planned and scheduled vault maintenance regime. Solid waste disposal can typically be coordinated with a local landfill, whereas liquid waste can be disposed of at either a wastewater treatment plant, or a municipal vacuum truck decant facility.

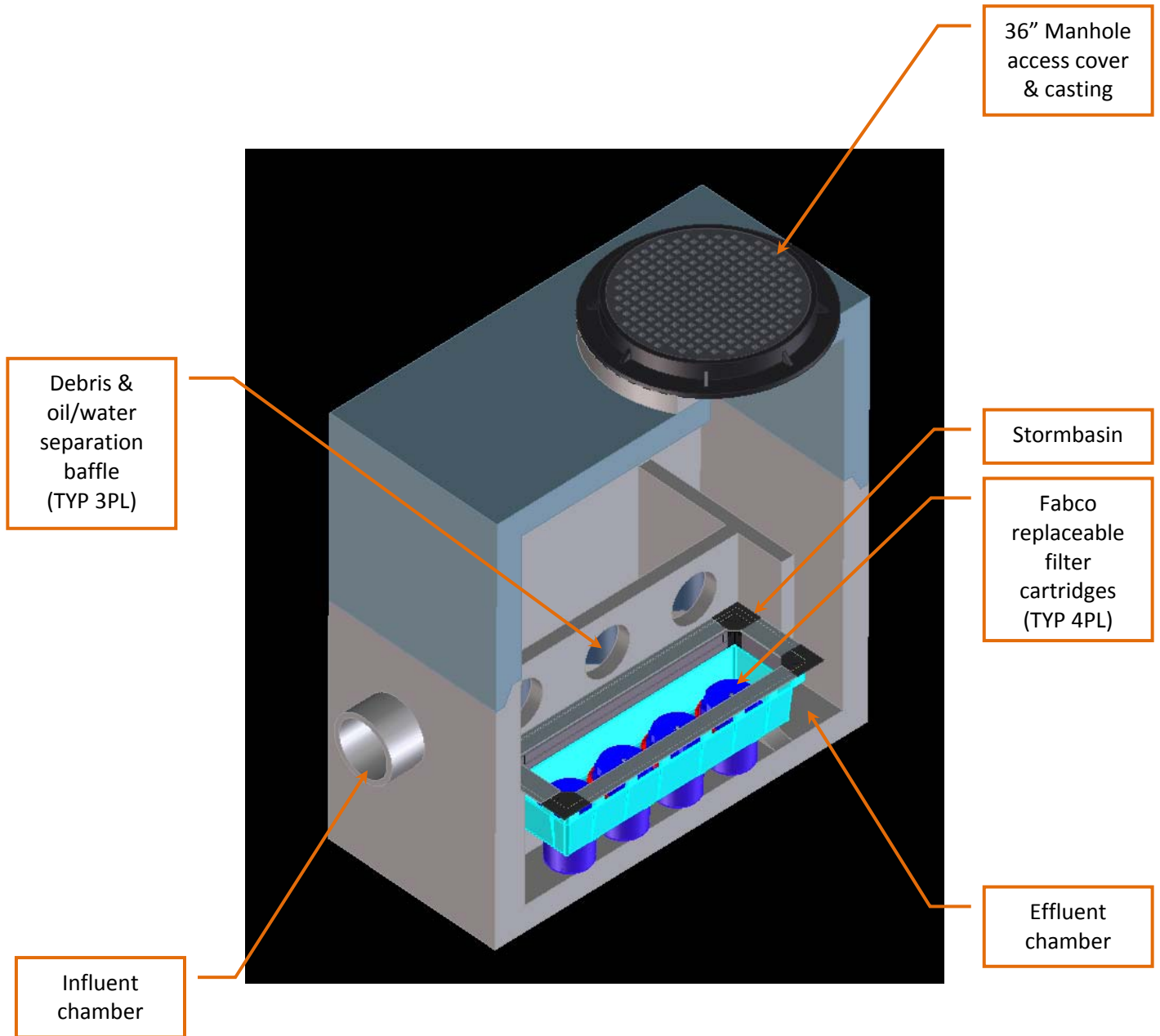

StormSafe-4C Detail (Figure 1)

<b><u>Inspection and Maintenance Log-Sheet</u></b>	
<b>StormSafe 4C – Stormwater Filtration Chamber</b>	
<b>Maintenance Company Information</b>	
Company Name:	
Onsite Technician:	
Contact Phone No:	
<b>StormSafe 4C - Vault Information</b>	
Date of Maintenance:	Fabco Vault P/N:
Vault Location:	
Water Depth (prior to maintenance):	<b><u>Comments</u></b>
Sediment Depth (prior to maintenance):	
Structural Damage:	
Maintenance Performed:	
Water level differential between chambers:	
Additional Work Required:	
Structural Repairs:	

FABCO INDUSTRIES, INC  
BEACH / HARBOR STORM WATER  
TEST PROGRAM



Prepared by:

Fabco Industries  
350 Jericho Turnpike, Ste 300  
Jericho, NY 11753  
Tel: 516-433-4148

Len Emma  
John Markee

### **Executive Summary**

Under an agreement between a local municipality and Fabco Industries, a Long Island based manufacturing firm, during the summer of 2006 a series of tests were performed on the Fabco catch basin inserts to evaluate their effectiveness in reducing certain identified bacteria contained in the surface water runoff. The product testing took place over a 90 day period at a beach front parking lot with known high levels of bacterial contamination. The device being tested was Fabco's StormBasin product which was supplied with two filter cartridges configured for maximum bacteria reduction.

The testing protocol focused on collecting efficiency data under real storm conditions. Only minimal maintenance was performed during the 90 day period and the same filtering cartridges were used from start to finish in order to better represent actual conditions. Sampling was also varied so that effectiveness could be measured during first flush as well as during the storm event. The report data presented here confirms that the StormBasin product was highly effective in reducing 3 types of indicator bacteria: E.Coli (77%), Enterococcus (49%) and Fecal Coliform (77%) .

Although not reported as part of the test, the StormBasin also collected considerable trash and debris such as plastic bottles and caps, candy wrapper, cigarette butts, and other material that would have been directed into the harbor.

# FABCO INDUSTRIES, INC BEACH / HARBOR STORM WATER TEST PROGRAM

## **Introduction:**

Rainwater flowing over paved surfaces can accumulate a variety of pollutants that in many cases are then transported and deposited in a storm sewer system. The more common pollutants associated with this runoff water include: sediments from simple erosive actions; oils, grease and even heavy metals such as chrome, zinc and cadmium from motor vehicles; nutrients, pesticides and other chemicals from agricultural activities, and potentially pathogenic organisms including bacteria that are released into the environment from poor land use, flawed waste disposal practices and other sources. In many cases this contaminated water finds its way to local rivers, lakes and estuaries, which results in the degradation of water quality. In fact, the EPA identifies surface water runoff as the leading contributor to water pollution.

Under section 303d of the Federal Clean Water act, each state is required to generate a list of impaired water ways that do not meet the water quality standards for their intended use. Currently, the EPA lists over 38,000 impaired waters in the United States. The top 5 impairments are: Mercury, Pathogens, Sediments, heavy metals (other than mercury) and nutrients.

This study focuses on the Fabco Industries StormBasin filter and its effectiveness in treating bacteria in surface water runoff. For these trials, Fabco StormBasin filters were installed in catch basin drains located in the parking field of a small public beach. This particular coastal area was selected based on a history of high bacterial counts following rain events, which may have contributed to beach closings and a prohibition of shell fishing in the area.

## **Background:**

The Fabco Industries StormBasin is a water-filtering system that installs below the iron grate of an existing storm water sewer. The StormBasin can be installed into most existing grated storm water drains without construction or other modifications. In this position the StormBasin intercepts and treats many of pollutants suspended and/or contained in surface water runoff including: sediments, trash and debris; oils, grease and other toxic hydrocarbon-based chemicals as well as potentially harmful bacteria

Related articles on bacteria, pathogens and the impact from storm water can be found on line at [www.oasisdesign.net](http://www.oasisdesign.net) and at the Federal EPA website: <http://www.epa.gov/beaches/>

### **The Technology:**

The Fabco StormBasin system consists of a large tub for the collection of raw water, sediments and debris and one or more filtering cartridges located at the bottom of the tub, which treat and discharge the clean water into the storm water system.

The StormBasin cartridges are selected based on actual pollutant loads and are user replaceable when required. Currently there are 4 different cartridge configurations to choose from: general purpose, hydrocarbons (oils & grease), bacteria and heavy metals. Each of the cartridge types applies one or more technologies in varying degrees to treat specific pollutants. For bacteria, the Fabco filter consists mainly of polymer foam treated with a proprietary antimicrobial technology.

The patented antimicrobial technology is applied as a liquid to the polymer foam material to form a colorless, odor-less, positively charged coating which chemically bonds, in a virtually irremovable manner, to the treated surface. At the microscopic level it resembles a layer of electrically charged stiff fibers or swords extending outward in all directions. When a microorganism comes in contact with the treated surface, the swords puncture the cell membrane and an electrical charge shocks the cell. Since nothing has been transferred to the now dead cell, the antimicrobial treatment doesn't lose strength and is ready for the next organism to contact it.

### **Site description:**

The sewer drain selected for the study had a 24"x48" grate and featured a rear open box inset into the concrete curb. Depth of the vault below the grate was approximately 40".

The drain was located in the Northeast corner of the parking field and serviced approximately 5900 square feet of black top paving. The parking field was slightly sloped towards the drain causing considerable accumulations of sediments, trash and debris.

Fabco Industries installed a 22"x 44" StormBasin (p/n 9731- 1E) which was configured for the rear open curb box. This configuration features a formed rubber flap that extends from the back edge of the tub into the rear open box. This flap enhances the unit's ability to capture the very low flows that are generated typically during the first flush period of a storm. The StormBasin selected featured two (2) Bacteria filtering cartridges p/n 9718-2 (Yellow ring)



### **Objectives:**

These field studies involved several major objectives. The most important of these was the evaluation of the effectiveness of the StormBasin filters to remove various bacteria contained in stormwater.

Secondly, as an integral part of the analysis of bacteria in stormwater, these studies were designed to provide valuable information with respect to the use of automatic/remote sampling systems Vs manual grab sampling. This aspect of the trials was of special interest in that very little comparative information was available concerning field sampling during storm events.

Thirdly, these trial runs were also focused on understanding the operational characteristics and effectiveness of the StormBasin when exposed to actual field conditions. Most importantly, while it was assumed that the unit would function in a first flush condition, based on static laboratory evidence, would it continue to be effective over an extended time and during continuous flow conditions that exist during a storm event.

A list of beaches listed under the National Beach Act can be found at <http://www.epa.gov/waterscience/beaches/list/list-of-beaches.pdf>. Information on Bacterial water quality standards can be found at: <http://www.epa.gov/waterscience/beaches/local/statrept.pdf>

**Methods:**

The sampling protocol called for the simultaneous collection of both an untreated and treated sample during a single rain event. The samples collected were evaluated by an independent laboratory<sup>1</sup> for reductions in the common indicator organisms: Fecal Coliform, E. coli and Enterococcus bacteria.

The monitoring would take place over an indefinite time period with little or no maintenance being performed on the unit during the monitoring period.

This report includes data accumulated during a 3-month period starting in August and ending in November of 2006. Samples were collected on 5 occasions. In total the site experienced 32 separate storm events where rain accumulations exceeded 0.01”

**Total rain events and accumulations  
(Observed daily data Long Island Mac Arthur AP)**

Time period	No# of days with precip	Time period	No# of days with precip
Aug. 14 – 31 Total 5.58	8 >= .01    6 >= 0.1 4 >= 0.5    2 >= 1.0 1 >= 2.0	Sept. 1 – 30 Total 4.29”	9 >= .01    7 >= 0.1 1 >= 0.5    1 >= 1.0 1 >= 2.0”
Oct. 1 – 31 Total 7.09”	12 >= .01    8 >= 0.1 4 >= 0.5    2 >= 1.0 2 >= 2.0	Nov. 1 – 8 Total 1.9”	3 >= .01    3 >= 0.1 1 >= 0.5    1 >= 1.0

Monitoring duration: 87 days / 32 storm events with >= 0.01” of rain  
Total rain fall >= 18.86” – See appendix D for monthly weather data

**Sampling dates and collection methods**

Sampling Date	Rain fall: 24 hrs	Collection method	Event
August 15	.09"	Auto	New cartridge/1 <sup>st</sup> flush
August 25	1.58"	Auto	Used Cartridge/ 1 <sup>st</sup> flush
September 14 (2 sets)	.58"	Auto & Manual	1 <sup>st</sup> flush / In process
October 20	.34"	Manual	In process
Nov 8	1.67"	Manual	In process

A new StormBasin was installed on August 14<sup>th</sup> at the start of the monitoring process. Weather data confirmed there had been no rain events for the first 14 days of the month.

Water samples would be collected either automatically or manually using a battery powered, Global Water, Model SS201 Storm water sampler (appendix F) and two standard bacteria cartridges.



The Global unit features a large, watertight plastic case and dual individually controlled peristaltic sampling pumps with 2 sample bottles. For this test, the standard 1-gallon sampling bottles were replaced with smaller 1 liter bottles. Use of the smaller bottles allowed us to insert refrigerated “cool” packs inside the case to refrigerate the samples. With this method adequate cooling as prescribed by EPA testing protocols could be maintained for about 12 to 16 hours.

To collect the water samples leaving the StormBasin special collection “pails” or “buckets” were designed to attach and seal directly to the bottom of the standard Fabco Cartridge body. In the image below, the standard cartridge body is dark blue. The collection pail area is a light green color and is sealed to the cartridge body with white tape.

#### Collection pail features:



- 1) A vertical over-flow pipe – To maintain approximately 2 liters of water in the pail while allowing excess water to escape.
- 2) A quick connect coupling – Connects pail to the supply line of the peristaltic pump and sample bottle.
- 3) A sensor switch - Activates pumps when the minimum level of water has accumulated in the pail.

Two collection pails were fabricated. The first was attached to the standard Fabco filtering cartridge. The second was attached to an empty cartridge- no filtering media. These two filters were then installed into the bottom of the StormBasin unit with the supplies lines routed to the Global Sampler.



**Sampling:**

During a storm event surface water enters the StormBasin, flows into and through the cartridges and collects in the pails. In automatic operation when approximately, 2 liters of water has collected, the sensor switch activates the pumps and two **First Flush** water samples are collected. The cartridge with the media left in place would supply a sample of treated water. The empty cartridge would collect a sample of untreated raw water.

Operational note: Prior to automatic testing on August 25 and September 14<sup>th</sup> the sampling cartridges were removed from the StormBasin in order to drain and clean the collection pails. During removal of the cartridges, collected sediments and debris were left undisturbed.

Manual samples were taken on September 14<sup>th</sup>, October 20<sup>th</sup> and on November 8<sup>th</sup>. These samples were acquired during the rain event and represent a snap shot of the treatment process. Manual samples were taken by pushing the ON button for each pump long enough to fill a sampling bottle. These samples were taken somewhere between 1 and 6 hours from the start of the storm. The filtering cartridges were not removed / cleaned before the manual sampling procedure as any water collected in the pails previous to the storm event would have been displaced.

**Results:**

The daily results of the monitoring study are presented in the attached tables A, B & C. In summary:

Bacteria	Min reduction	Max Reduction	Average
Fecal Coliform	64%	92%	77%
E.coli	64%	85%	77%
Enterococcus	11%	81%	49%

<sup>1</sup> Sample analysis provided by: EcoTest Laboratories Inc, 377 Sheffield Ave, North Babylon, NY 11703  
Tel: 631 422 5777 See Appendix E for individual daily reports

The StormBasin efficiency on Fecal Coliform and E.coli during the field study was somewhat expected based on previous dynamic cartridge studies performed for Fabco in local testing laboratories. These laboratory tests consistently showed a greater than 80% reduction in both bacteria types. However, these previous “bench studies” did not simulate real world conditions especially in terms of the actual water composition, suspended solids, flow rates and sampling difficulties. The results of these field studies, on the other hand, demonstrate that the cartridges are effective in the field and can continue to treat bacteria at high efficiency over time even with minimal maintenance.

This study also represents Fabco’s first testing on the Enterococcus bacteria. Compared to the results for E.coli and Fecal Coliform the cartridge does not seem as effective for this bacteria strain. But it is important to recognize here that there were unexplained large fluctuations in the reported results for enterococci that had a significant impact on the final results. It’s possible that the testing and/or sampling protocols need to be modified or reevaluated to better report on this type of bacteria. However we shouldn’t

lose sight that a 49% reduction of this bacteria combined with the nearly 80% reductions recorded for Fecal Coliform and E.coli does indicate good reductions in potentially pathogenic single cell bacteria overall.

**Conclusion:**

In summary, it is apparent that the Fabco StormBasin can provide significant reductions in the bacteria normally associated with stormwater.

This is particularly significant in view of the fact that the unit operated at a uniform level of efficiency for 3 months during which 32 individual storm events deposited nearly 19 inches of rain on the paved surfaces surrounding this drain. Moreover, the attendant accumulation of over 15 pounds of sediment and debris in the StormBasin did not have any measurable impact on the operational efficiency of the unit.

In general, good results were achieved with the use of the auto-sampling equipment. Analytical results indicated that samples collected with the equipment in the automatic mode were comparable to those collected manually.

Table A: Fabco Industries, StormBasin: effectiveness on E. coli bacteria

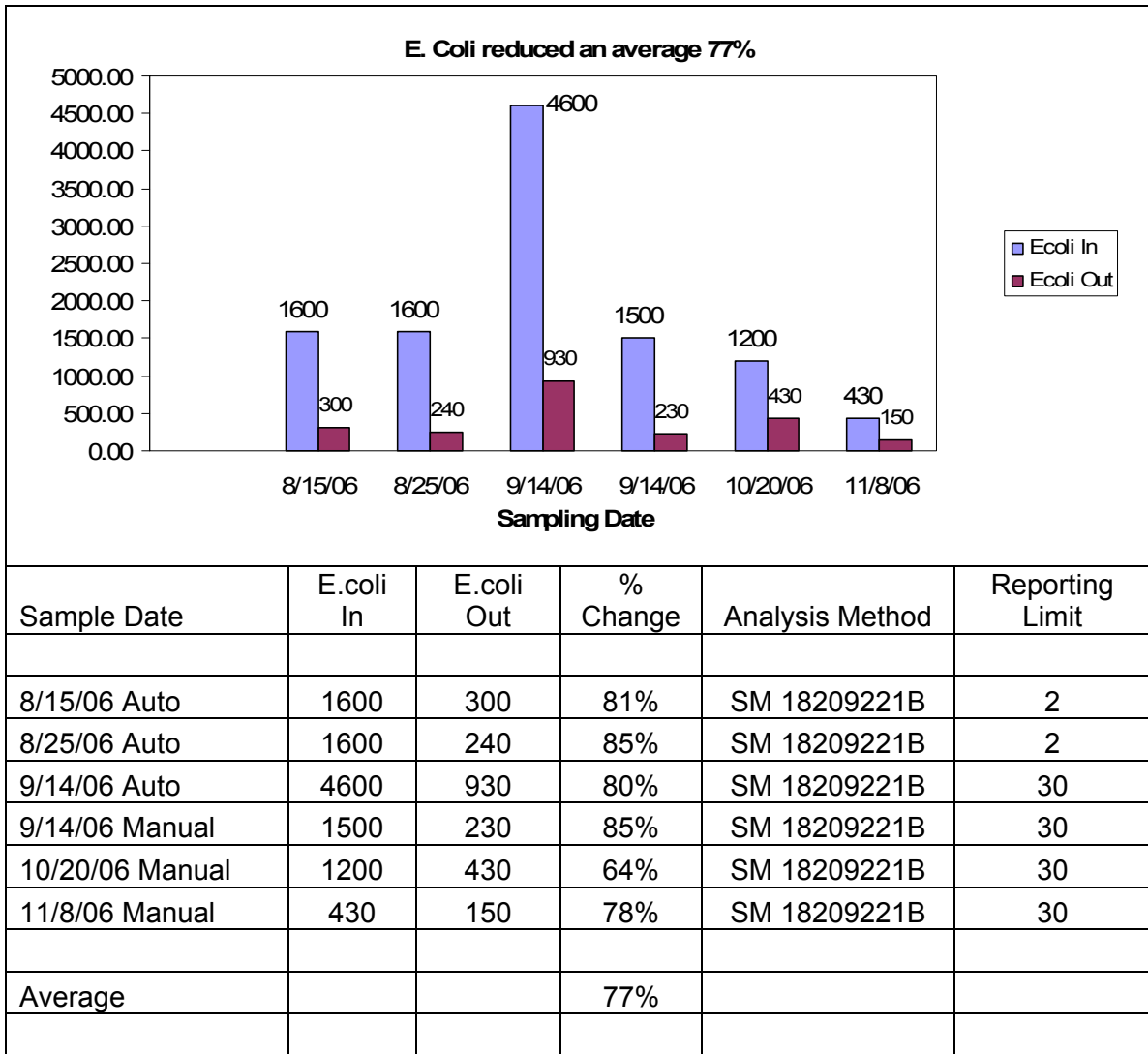

Table B: Fabco Industries, StormBasin: effectiveness on Fecal coliform bacteria

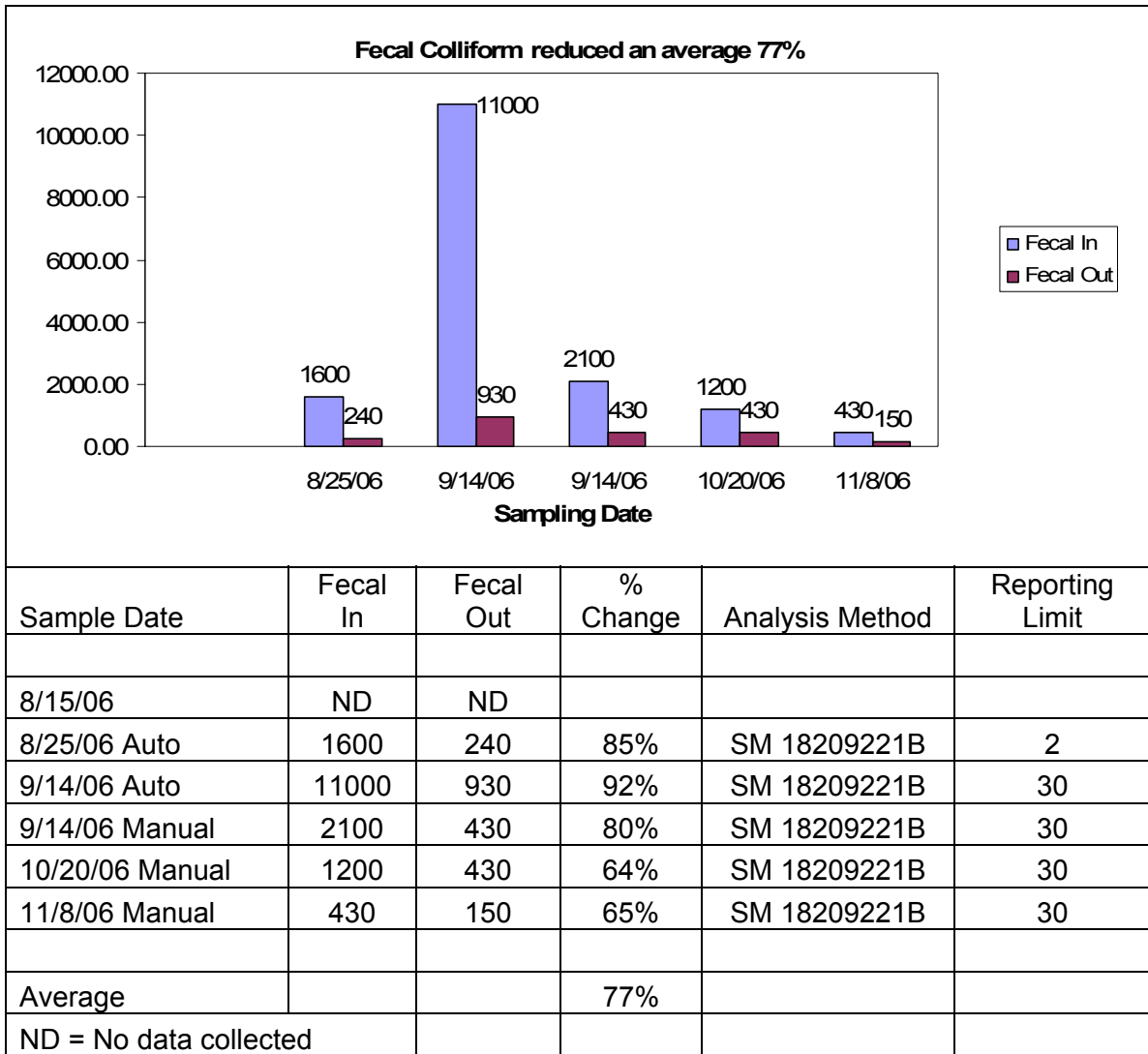
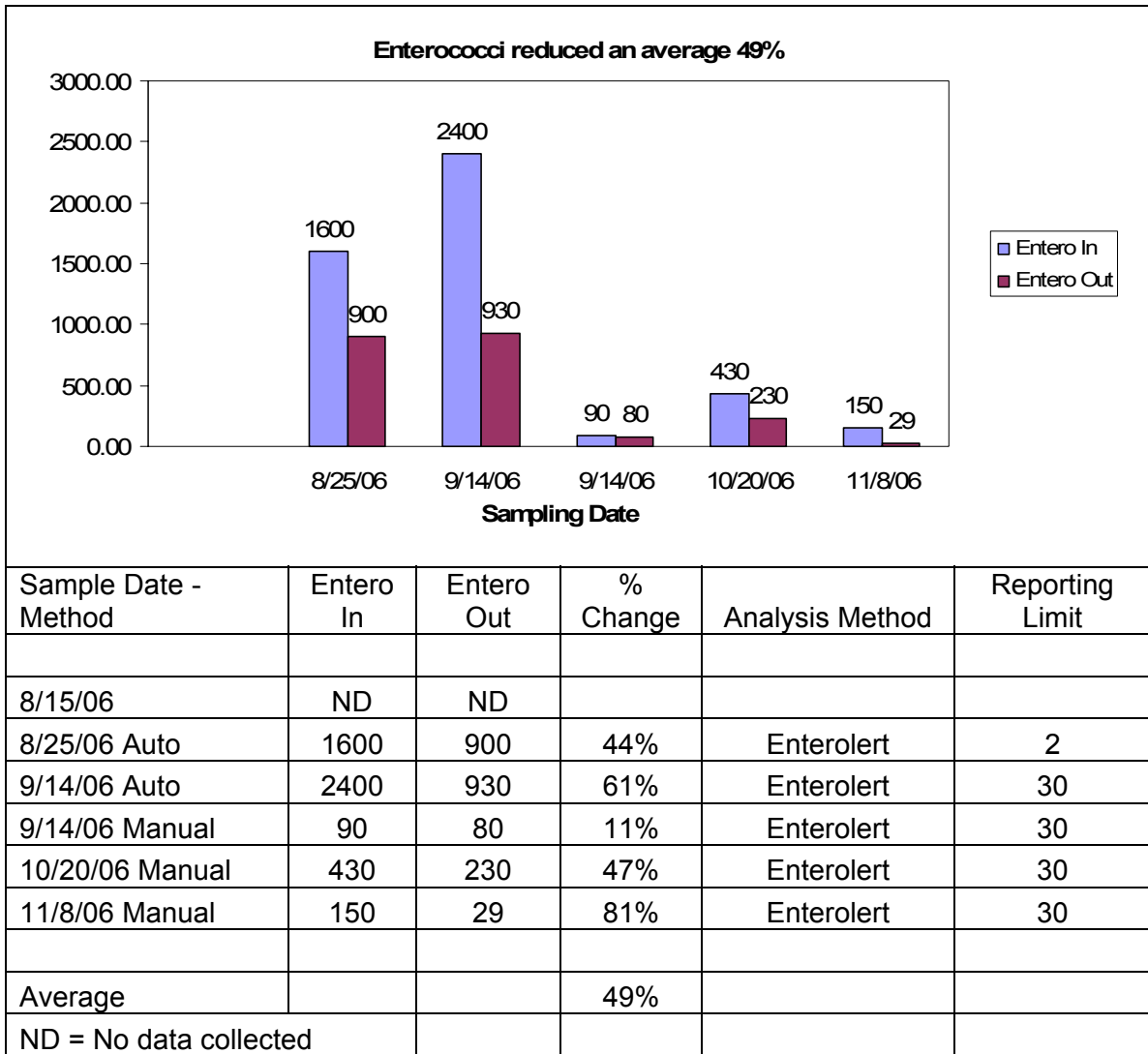

Table C: Fabco Industries, StormBasin: effectiveness on Enterococci bacteria



## References

Articles, papers, websites and guidance documents  
used in the preparation of the testing protocol

United States Environmental Protection Agency, Office of Science and Technology, Document EPA/821/R-97/004, March 2000: **Improved Enumeration Methods for Recreational Water Quality Indicators: Enterococci and Escherichia Coli**

United States Environmental Protection Agency, Office of Water (EN-336), Document 833-B-92-001, March 1992: **NPDES Storm Water Sampling Guidance Document**

Washington State Department of Ecology, Publication #02-10-071, December 2002 (rev.1/05): **How to do Stormwater sampling, A guide for industrial facilities.**

United States Environmental Protection Agency, Office of Research and Development National Exposure Research Laboratory, Cincinnati, OH 45268, August 2005, Larry J. Wymer, Kristen P. Brenner, John W. Martinson, Walter R. Stutts, Stephen A. Schaub, Alfred P. Dufour: **The EMPACT Beaches Project: Results from a study of Microbiological Monitoring in Recreational Waters**

United States Environmental Protection Agency, Office of Science and Technology, Document 823-R-99-002, March 1999: **Review of Potential Modeling Tools and Approaches to Support the BEACH Program**

United States Environmental Protection Agency, Office of Water Regulations and Standards, Criteria and Standards Division, Washington D.C, Document EPA440/5-84-002, January 1986: **Ambient Water Quality Criteria for Bacteria- 1986**

Forester Communications Inc., PO Box 3100, Santa Barbara, CA 93130, Stormwater Magazine, January/February 2002, Volume 3 Number 1, Author: Johnny Barron: **Sampling 101**

NOAA, National Oceanic and Atmospheric Administration, National Weather Service Forecast office, Observed Weather and NOWdata, View on the web at <http://www.weather.gov/climate/index.php?wfo=okx>

Websites for information on bacteria and testing

Eagles to the Nest, <http://www.iub.edu/~bradwood/eagles/fecal.htm>, Fecal Coliform Test, Class Room Activity

Switzerland County High School's Advanced Placement Environmental Science Class, Fecal Coliform: <http://www.switzerland.k12.in.us/watershed/fecal.html>

Oasis Designs, Fecal Coliform Bacteria Counts: What They Really Mean about water quality, <http://www.oasisdesign.net/water/quality/coliform.htm>

# STORMSAFE STORMWATER FILTER

## FEATURING HELIX FILTER TECHNOLOGY

Fabco Industries Inc, 66 Central Ave, Farmingdale, NY 11735  
 Tel: 631-393-6024 Fax: 631-501-5528 www.fabco-industries.com

### Pathogens in Stormwater

Stormwater runoff flowing over paved and unpaved surfaces picks up many types of contaminants including; oils, grease, heavy metals, nutrients and even potentially harmful organisms and bacteria such as E.coli, fecal coliform and Enterococcus.

These potentially harmful microorganisms are released primarily from fecal matter deposited on the surfaces by birds, wild animals or pet cats and dogs. Once they are assimilated into the water stream, they are easily transported through existing stormwater systems that can empty directly into local streams, lakes or estuaries. Here they can significantly impact the water quality causing both beach and shellfish area closings.

#### Treatment Media Technology

Fabco Industries a world leader in filtration media research and development with over 10 years experience in applying its proprietary treatment technologies to both industrial wastewater and storm water applications has introduced a new filter media named FabGuard, which has demonstrated significant effectiveness in reducing bacteria in stormwater.

FabGuard is a flexible, open pore foam material, with no intercellular membranes. The open skeletal structure can



*Escherichia Coli*

be manufactured with up to 98% open void volume providing high permeability for water transport. The foam is non-biodegradable, provides high tensile, elongation and tear properties and is extremely chemical resistant. It can be supplied in various shapes and sizes including: pads, socks and even chopped pieces. Fabco modifies this foam base material using a unique process to make it antimicrobially active.

FabGuard benefits:

1. Reduces bacteria by >50%
2. Antimicrobial treatment last the life of the foam
3. Safe – Non leaching – Non poisonous
4. Cost effective

FabGuard can be used as a pre-filter for other treatment media products to prevent biological fouling or by itself for maximum bacteria reductions.

## FabGuard Antimicrobial Filter Media

FABGUARD Antimicrobial Shield is a patented chemical technology, that when applied to Fabco's proprietary foam base material, forms a colorless, odorless, positively charged polymer coating, which chemically bonds, virtually irremovable, to the foam surface. The FABGUARD Antimicrobial Shield becomes an integral part of the foam and will not wash out, or leach into the environment. You could think of it as a layer of electrically charge swords or super stiff fibers extending outward perpendicular to the surface. Microorganisms that subsequently contact the fibers are neutralized and slough off leaving the surface ready for the next organism.

Conventional Antimicrobial products penetrate living cells and kill by way of poisoning the organism. This poisoning technology is applied to a host media where it slowly leaches, out creating a "killing field or zone" around the surface into which targeted microorganisms pass. They are

designed to act quickly and dissipate quickly in order to avoid adverse effects to humans and animals due to their toxic ingredients.

The FABGUARD Antimicrobial Shield takes a totally unique approach. The treated surface reduces bacteria by mechanical methods as opposed to chemical poisoning. It provides an effective initial microbial reduction, like the conventional methods, but the non-dissipating treatment also provides long-term growth control for the life of the treated product.

Bacteria that contacts the surface are neutralized and slough off leaving the surface ready for the next organism

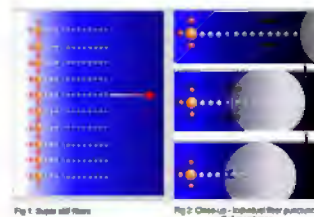

## *FabGuard Antimicrobial Filter Media from page 1*

### Testing

Initial bench scale testing of FabGuard was performed by New York Product Testing & Services<sup>1</sup> on Long Island.

A test solution containing a minimum concentration of between 2400 MPN/100ml and 3000 MPN/100ml of E.Coli bacteria was prepared. The solution was poured through two filter cartridges and the filtered solution was collected and analyzed for E.Coli concentrations. In both cases E.Coli concentrations were reduced to below 2 MPN/100 ml; a greater than 95% reduction.

While repetitions of this test yielded comparable results Fabco recognized that laboratory testing can not duplicate the actual stormwater matrix, flow rates and field conditions. Further verification testing would have to take place in the field. For this study it was decided to use Fabco's StormBasin Catch Basin Insert filter as a carrier device for the FabGuard media.

<sup>1</sup> New York Product Testing & Services, 110 Colin Drive, Holbrook, NY 11741

### FabGuard Field Study – Catch Basin Inserts

In many cases, the common catch basin or storm sewer drain is the first stop for contaminated stormwater flows. Effective filtration at this entry point would limit the mixing of possibly clean water with contaminated, yielding the greatest potential benefit. Although a number of catch basin insert filters are being sold, very few claim to treat more than oils & grease.

The Fabco StormBasin is a retro-fitable filtering device that installs into an existing catch basin drain by placing it across the inlet opening, just behind the grate; No modification or construction is required. All the water that would normally go through the grate is directed into the StormBasin filter.

The StormBasin uses the latest in plastic molding and metal forming technologies to provide leading edge features such as adjustable mounting kits, covered by-pass, and light weight corrosion resistant construction at an economical price. But its greatest feature is its ability to use replaceable filter cartridges that can be configured with five (5) different Fabco filter media products.

### Selection of Treatment Media Solutions

Fabco has developed and manufactures 5 different media types that can be used in various configurations within the cartridge: FabMax for oil sheen, FabSorb for higher concentration of oils and grease such as raw spills; FabPhos for soluble phosphates and nutrients, Fablite for heavy metals and for the bacteria testing project, our highly effective antimicrobial filter media, FabGuard.



StormBasin bacteria testing at a beach parking lot

### StormBasin BEACH / HARBOR STORM WATER TEST PROGRAM Executive Summary

Under an agreement between a local municipality and Fabco Industries during the summer of 2006, a series of tests were performed on the Fabco catch basin inserts to evaluate their effectiveness in reducing certain identified bacteria contained in the surface water runoff. The product testing took place over a 90 day period at a beach front parking lot with known high levels of bacterial contamination. The device being tested was Fabco's StormBasin product which was supplied with two filter cartridges configured for maximum bacteria reduction.

The testing protocol focused on collecting efficiency data under real storm conditions. Only minimal maintenance was performed during the 90 day period and the same filtering cartridges were used from start to finish in order to better represent actual conditions. Sampling was also varied so that effectiveness could be measured during first flush as well as during the storm event. The report data presented here confirms that the StormBasin product was highly effective in reducing 3 types of indicator bacteria: E.Coli (77%), Enterococcus (49%) and Fecal Coliform (77%).

The tests performed during this beach program confirmed that an environmentally safe antimicrobial agent could be applied to polypropylene foam filter material in a simple cost effective manner. The treated foam performed extremely well in its role as a pre-filter, keeping coarse matter from entering the filter, while maintaining long term antimicrobial effectiveness with very little evidence

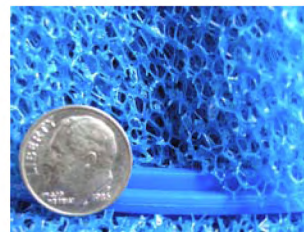

FabGuard open cell foam material

## *StormBasin Test program continued from page 2*

of degradation or physical breakdown. Additionally FabGuard was shown to be effective on stormwater flowing at approx. 70 to 100 gpm. This was something that could not be simulated in the laboratory bench scale testing.

While FabGuard performed very well in the StormBasin filter cartridges, catch basin inserts represent a single type of stormwater BMP. Following the StormBasin testing, Fabco began to investigate the application of FabGuard in larger systems such as underground vaults.

## Helix Filter Technology

### Improving Filter Technology

FABGUARD Antimicrobial technology forms an antimicrobial coating on all external and internal surfaces of the foam filter material. In order to treat the flow rates expected in an underground vault, interstitial surface volume in the foam must be maximized by increasing one of more of the following parameters: number of pads, pad thickness or pad density. However, these changes have a detrimental effect on flow. Additionally, coarse solids such as sediments, trash and debris contained in stormwater also collect in the filter further compounding the reduction in flow. In order to maintain high flow rates with maximum effectiveness, a change in the filter process beyond the FabGuard filter media was needed.

### Two Step Treatment Process

Existing stormwater filters combine large concrete vaults with vast numbers of slow flowing filter cartridges. These units attempt to capture sediments, trash and debris on top of the cartridges while only a trickle of water is allowed through the filter. These units are large and expensive; while future servicing and cleaning between a multitude of cartridges is difficult, time consuming and costly. Fabco takes a different approach.

To reduce clogging from sediments, debris and trash the Fabco filter is designed as a secondary vault following behind primary sediment separation. The idea is similar to the multi step wastewater treatment process. All the coarse material is captured in a vault designed solely for that purpose. A sediment separator: treats more water at a higher flow rates; can be serviced from surface level with a Vac-truck and the pre-treated water will keep the Fabco filters cleaner maintaining flow rates and effectiveness while requiring minimal service.

### Patented Helix Filter Technology

To treat high flow rates of water Fabco developed a new dual-helix FabGuard filter held horizontally in a plastic pipe.

The horizontal pipe design provides great flexibility for selecting the appropriate filter length and diameter. The dual helix filter element functions like a multiple disk filter providing tremendous surface volume for treatment.

The spiral form also supplies multiple flow paths through the filter continuously exposing new surfaces while significantly reducing clogging potential.



Fig. 1  
Helix Filter segment: A multi spoke frame is used as a skeleton to hold the FabGuard material in a disk-like shape. The design provides two (2) open channels or pathways through the filter to reduce clogging.



Fig. 2  
A complete Helix Filter column consists of 3 or more Helix Filter segments inserted horizontally into a smooth lined plastic corrugated pipe. Each Helix Filter column will treat approximately 2.5 CFS.

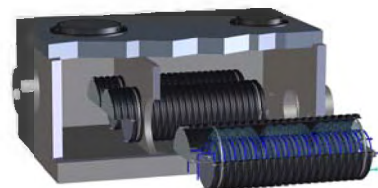

Fig. 3  
The final stormwater treatment system is completed by installing one or more Helix Filter columns inside a concrete vault

## *Helix Filter Technology continued from page 3*

### Flow Testing the Helix Filter

Testing of a completed Helix Filter column began with flow testing at close to maximum rates. In this test, a single, 30 inch diameter column filter, featuring 3 helical segments was inserted into an ADS-Nyloplast plastic pipe. A vertical riser was added to the horizontal pipe to accept the water and measure head pressure.

The complete assembly was moved to a nearby lake where it was connected to a large pump capable of more than 4.0 CFS flow rates.

During the test, flow rates were increased up to a maximum of 1350 gpm/ 3CFS and held at that rate for nearly two hours. At the end of the testing, nearly 300,000 gallons of water passed through the filter with virtually no increase in head pressure.

### Field Testing the Helix Filter

Having completed flow testing the next field trial would measure bacteria reduction efficiencies.

For bacteria testing, two (2) 10" diameter Helix Filter columns featuring 4 and then 5 in-line filter segments were selected. Again each filter column was connected to a vertical riser which would allow us to measure head pressure change.

The unit was transported to a local lake where it was plumbed to a 1000 gallon collection tank. The tank featured a 4 inch diameter outlet pipe from the bottom with an in-line mechanical flow gauge.

Using a separate collection tank allowed us to pump a known volume of water from the lake into the tank to use as a reservoir during the test. Previous testing using a pump directly had shown that bacteria levels could vary significantly from one grab sample to the next. Using the tank allowed us to grab multiple samples from this single source allowing better characterization of the average value for the influent introduced to the Helix Filter.

Likewise, the outlet from the Helix Filter was allowed to collect in a 75 gallon plastic bin. Sampling of the effluent was performed using disposable Coliwassas samplers which provided us with a vertical cross-sectional sample of the water from top to bottom. Five (5) discrete samples of influent and effluent were used to develop the average value used in the test.

For the purpose of this test only Total Coliform and Fecal Coliform indicator organisms were measured.

System flow rate during test was regulated to approx. 50 gpm. Although seemingly low, a simple mathematical model demonstrated that 50 gpm in a 10" Helix Filter was equivalent to more than 1200 gpm in a 30" Helix Filter.



### Field testing result summary

4 Segment Helix Filter	Total Coli	Fecal Coli
Influent (MPN/100 ml)	3120	2780
Effluent (MPN/100 ml)	1220	1000
% Reduction	61%	64%
5 Segment Helix Filter	T. coli	Fecal
Influent (MPN/100 ml)	4388	3948
Effluent (MPN/100 ml)	1360	934
% Reduction	69%	76%

### Summary

The results of the Helix Filter testing confirmed that the FabGuard technology was transferable from the vertical StormBasin cartridge to a horizontal Helix Filter configuration. During field trials the two systems reduced coliform bacteria by a nearly identical 70%.

When combined with a primary sediment separator the StormSafe provides an excellent long term solution to the problem of pathogens and bacteria contamination in stormwater flows. The StormSafe offers high flow rates, an anti-clog self cleaning action and long term effectiveness in a user replaceable filter cartridge.

Currently, Fabco offers Helix Filter cartridges for pathogens/bacteria as well as a special filter for oils, grease and other hydrocarbons. For the future, the Helix Filter configuration offers many avenues for upgrading its effectiveness. For example, the pitch of the helix could be varied increasing the number of disks per segment; or the density of the foam could be increased which would increase the surface volume aiding FabGuard effectiveness. Both of these aspects could be used to treat higher levels of bacterial contamination. Fabco is also investigating the use of its FabPhos media for reducing orthophosphates and other soluble nutrients.

Fabco Industries, Inc  
66 Central Ave  
Farmingdale, NY 11735  
(631) 393-6024  
www.fabco-industries.com



MODULAR  
WETLANDS™

*Advanced Stormwater Biofiltration*

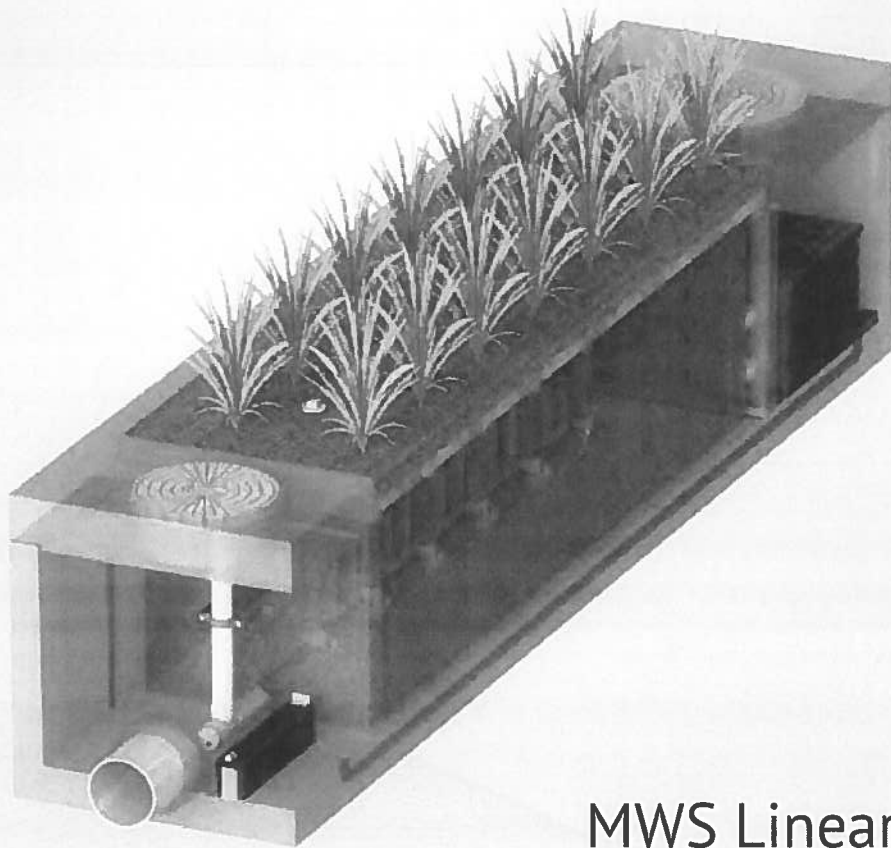

MWS Linear



# Contents

- 1 Introduction
- 2 Applications
- 3 Configurations
- 4 Advantages
- 5 Operation
- 6 Orientations | Bypass
- 7 Performance | Approvals
- 8 Sizing
- 9 Installation | Maintenance | Plants

# The Urban Impact

For hundreds of years natural wetlands surrounding our shores have played an integral role as nature's stormwater treatment system. But as our cities grow and develop, these natural wetlands have perished under countless roads, rooftops, and parking lots.



## Plant A Wetland

Without natural wetlands our cities are deprived of water purification, flood control, and land stability. Modular Wetlands and the MWS Linear re-establish nature's presence and rejuvenate water ways in urban areas.



## MWS Linear

The Modular Wetland System Linear represents a pioneering breakthrough in stormwater technology as the only biofiltration system to utilize patented horizontal flow, allowing for a smaller footprint and higher treatment capacity. While most biofilters use little or no pre-treatment, the MWS Linear incorporates an advanced pre-treatment chamber that includes separation and pre-filter cartridges. In this chamber sediment and hydrocarbons are removed from runoff before it enters the biofiltration chamber, in turn reducing maintenance costs and improving performance.

# Applications

The MWS Linear has been successfully used on numerous new construction and retrofit projects. The system's superior versatility makes it beneficial for a wide range of stormwater and waste water applications - treating rooftops, streetscapes, parking lots, and industrial sites.



## Industrial

Many states enforce strict regulations for discharges from industrial sites. The MWS Linear has helped various sites meet difficult EPA mandated effluent limits for dissolved metals and other pollutants.



## Residential

Low to high density developments can benefit from the versatile design of the MWS Linear. The system can be used in both decentralized LID design and cost-effective end-of-the-line configurations.



## Streets

Street applications can be challenging due to limited space. The MWS Linear is very adaptable, and offers the smallest footprint to work around the constraints of existing utilities on retrofit projects.



## Parking Lots

Parking lots are designed to maximize space and the MWS Linear's 4 ft. standard planter width allows for easy integration into parking lot islands and other landscape medians.



## Commercial

Compared to bioretention systems, the MWS Linear can treat far more area in less space - meeting treatment and volume control requirements.



## Mixed Use

The MWS Linear can be installed as a raised planter to treat runoff from rooftops or patios, making it perfect for sustainable "live-work" spaces.

More applications are available on our website: [www.ModularWetlands.com/Applications](http://www.ModularWetlands.com/Applications)

- Agriculture
- Low Impact Development
- Reuse
- Waste Water



## Configurations

The MWS Linear is the preferred biofiltration system of Civil Engineers across the country due to its versatile design. This highly versatile system has available “pipe-in” options on most models, along with built-in curb or grated inlets for simple integration into your stormdrain design.



### Curb Type

The *Curb Type* configuration accepts sheet flow through a curb opening and is commonly used along road ways and parking lots. It can be used in sump or flow by conditions. Length of curb opening varies based on model and size.



### Grate Type

The *Grate Type* configuration offers the same features and benefits as the *Curb Type* but with a grated/drop inlet above the systems pre-treatment chamber. It has the added benefit of allowing for pedestrian access over the inlet. ADA compliant grates are available to assure easy and safe access. The *Grate Type* can also be used in scenarios where runoff needs to be intercepted on both sides of landscape islands.

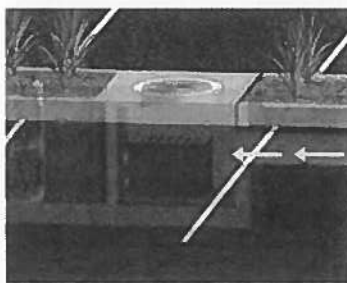

### Vault Type

The system's patented horizontal flow biofilter is able to accept inflow pipes directly into the pre-treatment chamber, meaning the MWS Linear can be used in end-of-the-line installations. This greatly improves feasibility over typical decentralized designs that are required with other biofiltration/bioretenion systems. Another benefit of the “pipe in” design is the ability to install the system downstream of underground detention systems to meet water quality volume requirements.



### Downspout Type

The *Downspout Type* is a variation of the *Vault Type* and is designed to accept a vertical downspout pipe from roof top and podium areas. Some models have the option of utilizing an internal bypass, simplifying the overall design. The system can be installed as a raised planter and the exterior can be stuccoed or covered with other finishes to match the look of adjacent buildings.

# Advantages & Operation

The MWS Linear is the most efficient and versatile biofiltration system on the market, and the only system with horizontal flow which improves performance, reduces footprint, and minimizes maintenance. Figure-1 and Figure-2 illustrate the invaluable benefits of horizontal flow and the multiple treatment stages.

## Featured Advantages

- Horizontal Flow Biofiltration
- Greater Filter Surface Area
- Pre-Treatment Chamber
- Patented Perimeter Void Area
- Flow Control
- No Depressed Planter Area

## 1 Pre-Treatment

### Separation

- Trash, sediment, and debris are separated before entering the pre-filter cartridges
- Designed for easy maintenance access

### Pre-Filter Cartridges

- Over 25 ft<sup>2</sup> of surface area per cartridge
- Utilizes BioMediaGREEN filter material
- Removes over 80% of TSS & 90% of hydrocarbons
- Prevents pollutants that cause clogging from migrating to the biofiltration chamber

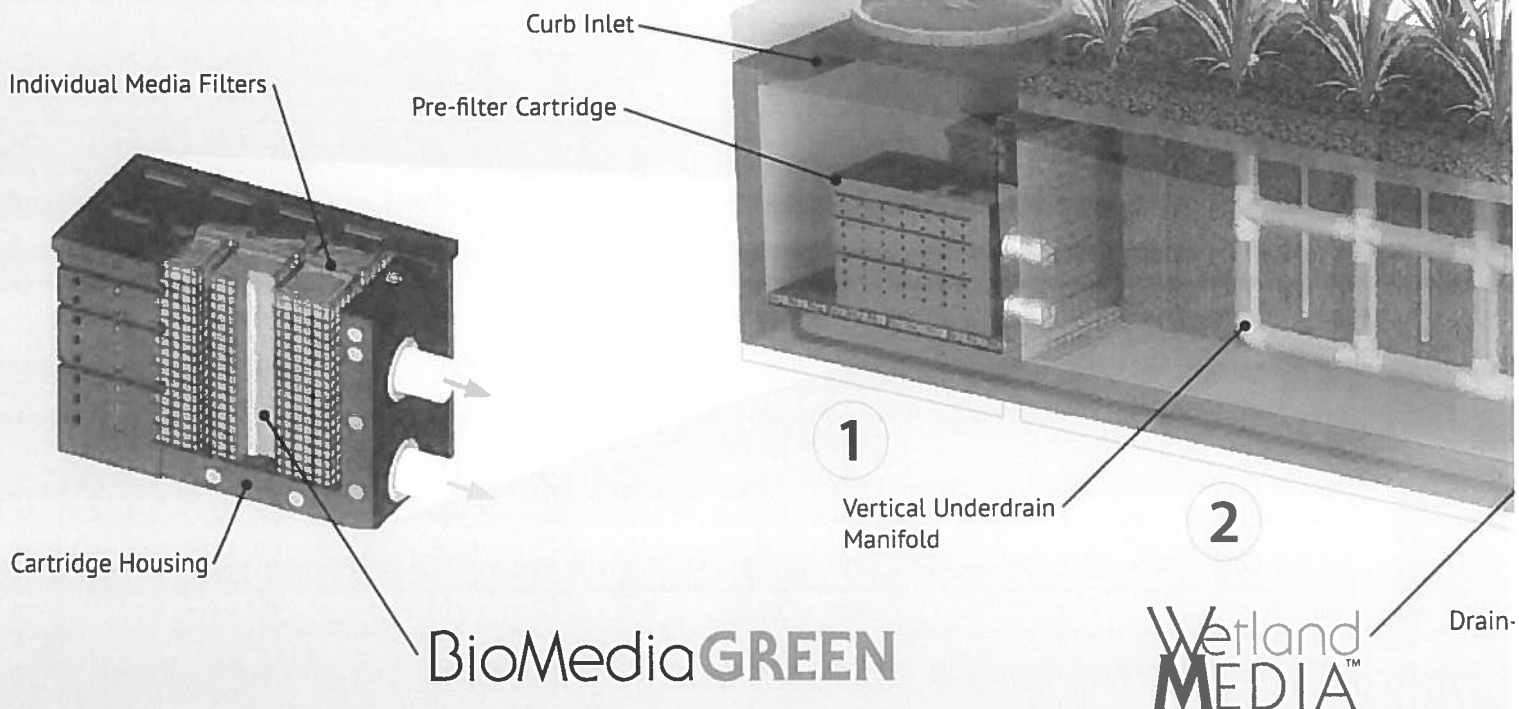

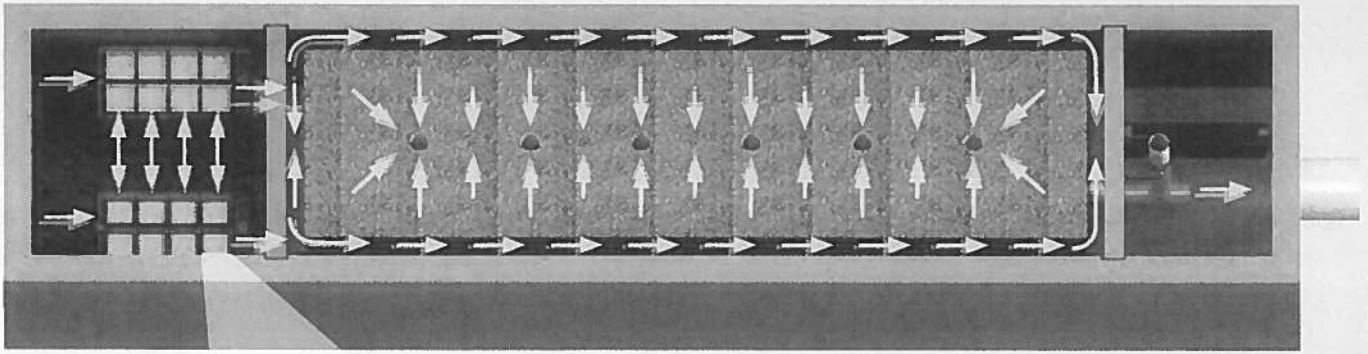
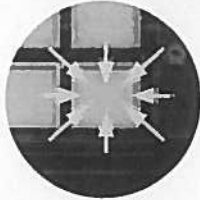

Fig. 2 - Top View

2x to 3x More Surface Area Than Traditional Downward Flow Bioretention Systems.



## 2 Biofiltration

### Horizontal Flow

- Less clogging than downward flow biofilters
- Water flow is subsurface
- Improves biological filtration

### Patented Perimeter Void Area

- Vertically extends void area between the walls and the WetlandMEDIA on all four sides.
- Maximizes surface area of the media for higher treatment capacity

### WetlandMEDIA

- Contains no organics and removes phosphorus
- Greater surface area and 48% void space
- Maximum evapotranspiration
- High ion exchange capacity and light weight

## 3 Discharge

### Flow Control

- Orifice plate controls flow of water through WetlandMEDIA to a level lower than the media's capacity.
- Extends the life of the media and improves performance

### Drain-Down Filter

- The Drain-Down is an optional feature that completely drains the pre-treatment chamber
- Water that drains from the pre-treatment chamber between storm events will be treated

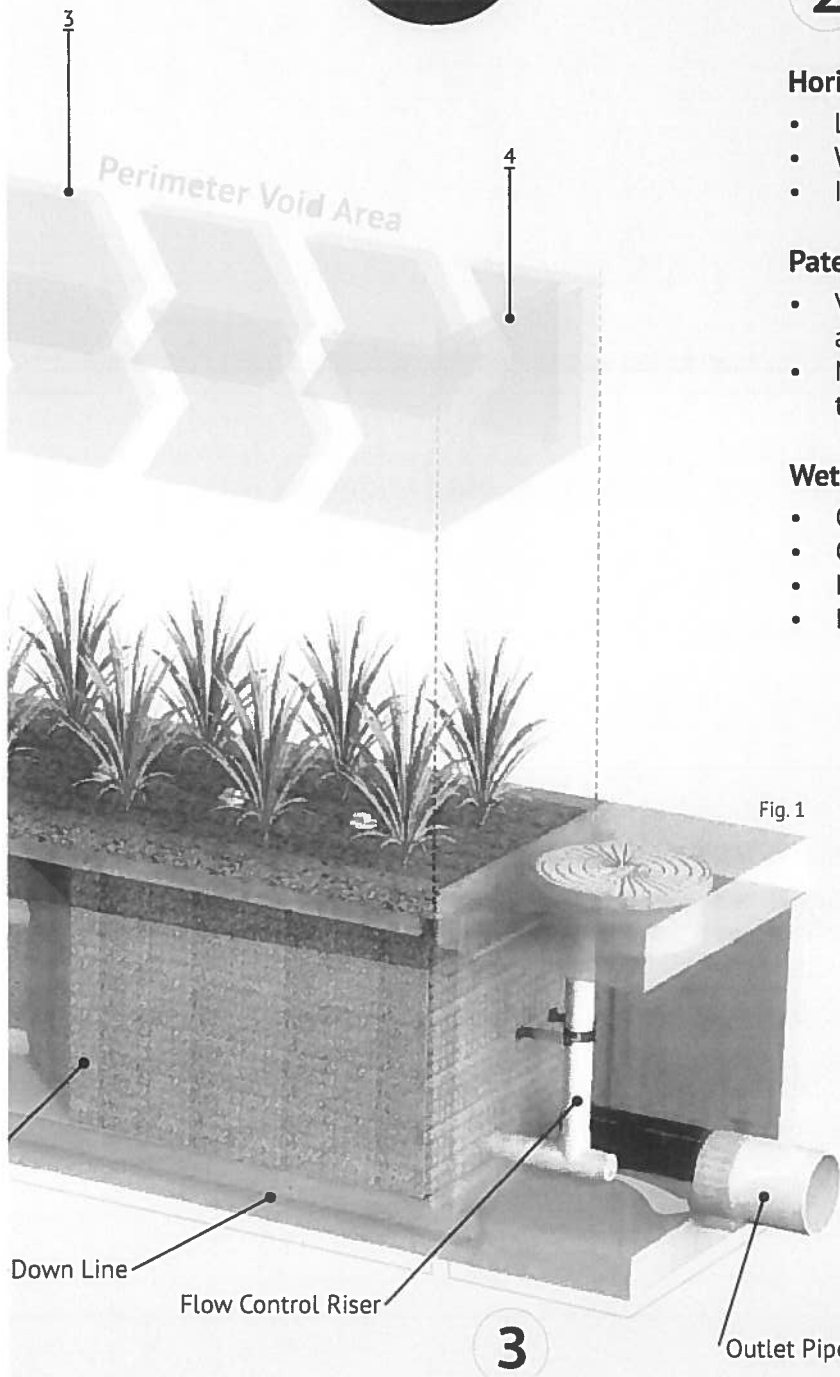

Fig. 1

# Orientations



## Side-By-Side

The *Side-By-Side* orientation places the pre-treatment and discharge chamber adjacent to one another with the biofiltration chamber running parallel on either side. This minimizes the system length, providing a highly compact footprint. It has been proven useful in situations such as streets with directly adjacent sidewalks, as half of the system can be placed under that sidewalk. This orientation also offers internal bypass options as discussed below.

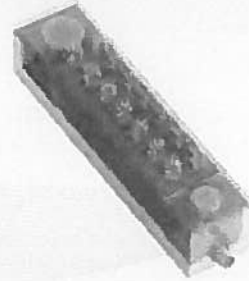

## End-To-End

The *End-To-End* orientation places the pre-treatment and discharge chambers on opposite ends of the biofiltration chamber therefore minimizing the width of the system to 5 ft (outside dimension). This orientation is perfect for linear projects and street retrofits where existing utilities and sidewalks limit the amount of space available for installation. One limitation of this orientation is bypass must be external.

# Bypass

## Internal Bypass Weir (Side-by-Side Only)

The *Side-By-Side* orientation places the pre-treatment and discharge chambers adjacent to one another allowing for integration of internal bypass. The wall between these chambers can act as a bypass weir when flows exceed the system's treatment capacity, thus allowing bypass from the pre-treatment chamber directly to the discharge chamber.

## External Diversion Weir Structure

This traditional offline diversion method can be used with the MWS Linear in scenarios where runoff is being piped to the system. These simple and effective structures are generally configured with two outflow pipes. The first is a smaller pipe on the upstream side of the diversion weir - to divert low flows over to the MWS Linear for treatment. The second is the main pipe that receives water once the system has exceeded treatment capacity and water flows over the weir.

## Flow By Design

This method is one in which the system is placed just upstream of a standard curb or grate inlet to intercept the first flush. Higher flows simply pass by the MWS Linear and into the standard inlet downstream.

## DVERT Low Flow Diversion

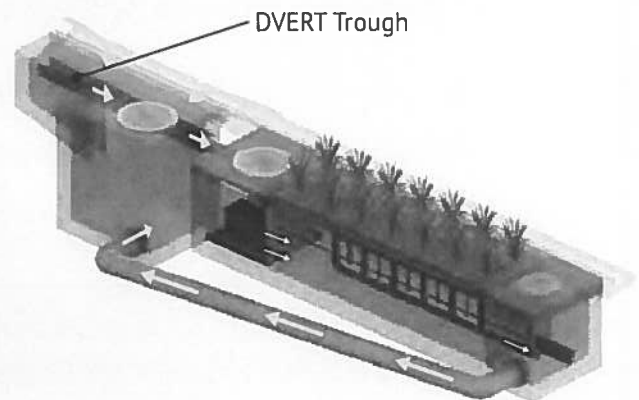

This simple yet innovative diversion trough can be installed in existing or new curb and grate inlets to divert the first flush to the MWS Linear via pipe. It works similar to a rain gutter and is installed just below the opening into the inlet. It captures the low flows and channels them over to a connecting pipe exiting out the wall of the inlet and leading to the MWS Linear. The DVERT is perfect for retrofit and green street applications that allows the MWS Linear to be installed anywhere space is available.



## Performance

The MWS Linear continues to outperform other treatment methods with superior pollutant removal for TSS, heavy metals, nutrients, hydrocarbons and bacteria. Since 2007 the MWS Linear has been field tested on numerous sites across the country. With its advanced pre-treatment chamber and innovative horizontal flow biofilter, the system is able to effectively remove pollutants through a combination of physical, chemical, and biological filtration processes. With the same biological processes found in natural wetlands, the MWS Linear harnesses nature's ability to process, transform, and remove even the most harmful pollutants.

## Approvals

The MWS Linear has successfully met years of challenging technical reviews and testing from some of the most prestigious and demanding agencies in the nation, and perhaps the world.



### Washington State DOE Approved

The MWS Linear is approved for General Use Level Designation (GULD) for Basic, Enhanced, and Phosphorus treatment at 1 gpm/ft<sup>2</sup> loading rate. The highest performing BMP on the market for all main pollutant categories.

TSS	Total Phosphorus	Ortho Phosphorus	Nitrogen	Dissolved Zinc	Dissolved Copper	Total Zinc	Total Copper	Motor Oil
85%	64%	67%	45%	66%	38%	69%	50%	95%



### DEQ Assignment

The Virginia Department of Environmental Quality assigned the MWS Linear, the highest phosphorus removal rating for manufactured treatment devices to meet the new Virginia Stormwater Management Program (VSMP) Technical Criteria.



### MASTEP Evaluation

The University of Massachusetts at Amherst – Water Resources Research Center, issued a technical evaluation report noting removal rates up to 84% TSS, 70% Total Phosphorus, 68.5% Total Zinc, and more.



### Rhode Island DEM Approved

Approved as an authorized BMP and noted to achieve the following minimum removal efficiencies: 85% TSS, 60% Pathogens, 30% Total Phosphorus for discharges to freshwater systems, and 30% Total Nitrogen for discharges to saltwater or tidal systems.

## Flow Based Sizing

The MWS Linear can be used in stand alone applications to meet treatment flow requirements. Since the MWS Linear is the only biofiltration system that can accept inflow pipes several feet below the surface it can be used not only in decentralized design applications but also as a large central end-of-the-line application for maximum feasibility.

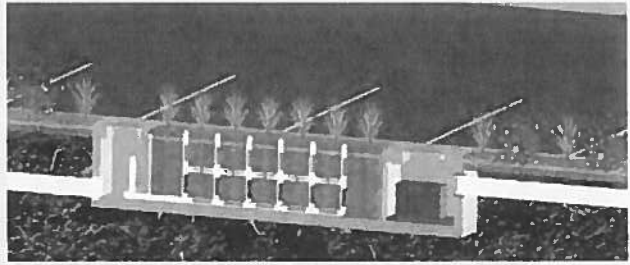

### Treatment Flow Sizing Table

Model #	Dimensions	Wetland Media Surface Area	Treatment Flow Rate (cfs)
MWS-L-4-4	4' x 4'	23 ft <sup>2</sup>	0.052
MWS-L-4-6	4' x 6'	32 ft <sup>2</sup>	0.073
MWS-L-4-8	4' x 8'	50 ft <sup>2</sup>	0.115
MWS-L-4-13	4' x 13'	63 ft <sup>2</sup>	0.144
MWS-L-4-15	4' x 15'	76 ft <sup>2</sup>	0.175
MWS-L-4-17	4' x 17'	90 ft <sup>2</sup>	0.206
MWS-L-4-19	4' x 19'	103 ft <sup>2</sup>	0.237
MWS-L-4-21	4' x 21'	117 ft <sup>2</sup>	0.268
MWS-L-8-8	8' x 8'	100 ft <sup>2</sup>	0.230
MWS-L-8-12	8' x 12'	151 ft <sup>2</sup>	0.346
MWS-L-8-16	8' x 16'	201 ft <sup>2</sup>	0.462

## Volume Based Sizing

Many states require treatment of a water quality volume and do not offer the option of flow based design. The MWS Linear and its unique horizontal flow makes it the only biofilter that can be used in volume based design installed downstream of ponds, detention basins, and underground storage systems.

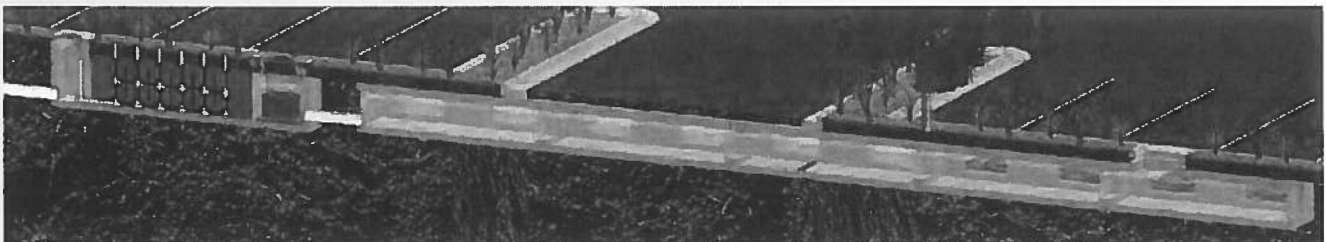

### Treatment Volume Sizing Table

Model #	Treatment Capacity (cu. ft.) @ 24-Hour Drain Down	Treatment Capacity (cu. ft.) @ 48-Hour Drain Down
MWS-L-4-4	1140	2280
MWS-L-4-6	1600	3200
MWS-L-4-8	2518	5036
MWS-L-4-13	3131	6261
MWS-L-4-15	3811	7623
MWS-L-4-17	4492	8984
MWS-L-4-19	5172	10345
MWS-L-4-21	5853	11706
MWS-L-8-8	5036	10072
MWS-L-8-12	7554	15109
MWS-L-8-16	10073	20145

## Installation

The MWS Linear is simple, easy to install, and has a space efficient design that offers lower excavation and installation costs compared to traditional tree-box type systems. The structure of the system resembles pre-cast catch basin or utility vaults and is installed in a similar fashion.

The system is delivered fully assembled for quick installation. Generally, the structure can be unloaded and set in place in 15 minutes. Our experienced team of field technicians are available to supervise installations and provide technical support.



## Maintenance

Reduce your maintenance costs, man hours, and materials with the MWS Linear. Unlike other biofiltration systems that provide no pre-treatment, the MWS Linear is a self-contained treatment train which incorporates simple and effective pre-treatment.

Maintenance requirements for the biofilter itself are almost completely eliminated, as the pre-treatment chamber removes and isolates trash, sediments, and hydrocarbons. What's left is the simple maintenance of an easily accessible pre-treatment chamber that can be cleaned by hand or with a standard vac truck. Only periodic replacement of low-cost media in the pre-filter cartridges is required for long term operation and there is absolutely no need to replace expensive biofiltration media.



## Plant Selection

Abundant plants, trees, and grasses bring value and an aesthetic benefit to any urban setting, but those in the MWS Linear do even more - they increase pollutant removal. What's not seen, but very important, is that below grade the stormwater runoff/flow is being subjected to nature's secret weapon: a dynamic physical, chemical, and biological process working to break down and remove non-point source pollutants. The flow rate is controlled in the MWS Linear, giving the plants more "contact time" so that pollutants are more successfully decomposed, volatilized and incorporated into the biomass of The MWS Linear's micro/macro flora and fauna.

A wide range of plants are suitable for use in the MWS Linear, but selections vary by location and climate. View suitable plants by selecting the list relative to your project location's hardy zone.

Please visit [www.ModularWetlands.com/Plants](http://www.ModularWetlands.com/Plants) for more information and various plant lists.







# Installation Guidelines for Modular Wetland System

## Delivery & Unloading/Lifting

1. Modular Wetland Systems, Inc. shall deliver the unit(s) to the site in coordination with the Contractor.
2. The Contractor will require spreader bars and chains/cables to safely and securely lift the main structure, lids and risers (if applicable). Modular Wetlands will supply a set of suitable lifting hooks, knuckles, shackles and eye bolts with each project at no extra charge.
3. The main structure and lid can be lifted together or separately.

*Please see Modular Wetland Weights and Lifting Details. Contact Modular Wetlands for additional lifting details.*

## Inspection

1. Inspection of the Modular Wetland unit and all parts contained in or shipped outside of the unit shall be inspected at time of delivery by the site Engineer/Inspector and the Contractor. Any non-conformance to approved drawings or damage to any part of the system shall be documented on the Modular Wetland shipping ticket. Damage to the unit during and after unloading shall be corrected at the expense of the Contractor. Any necessary repairs to the Modular Wetland unit shall be made to the acceptance of the Engineer/Inspector.

## Site Preparation

1. The Contractor is responsible for providing adequate and complete site/inlet protection when the Modular Wetland unit is installed prior to final site stabilization (full landscaping, grass cover, final paving, and street sweeping completed).
2. The Contractor shall adhere to all jurisdictional and/or OSHA safety rules in providing temporary shoring of the excavation.
3. The Contractor or Owner is responsible for appropriately barricading the Modular Wetland unit from traffic (in accordance with local codes).



# Installation Guidelines for Modular Wetland System

## Installation

1. Each unit shall be constructed at the locations and elevations according to the sizes shown on the approved drawings. Any modifications to the elevation or location shall be at the direction of and approved by the Engineer.
2. The unit shall be placed on the compacted sub-grade with a minimum 6-inch gravel base matching the final grade of the curb line in the area of the unit. The unit is to be placed such that the unit and top slab match the grade of the curb in the area of the unit. Compact undisturbed sub-grade materials to 95% of maximum density at +1% to 2% of the optimum moisture. Unsuitable material below sub-grade shall be replaced to site engineer's approval. Please see Modular Wetlands Weights and Lifting Details. Contact Modular Wetlands for guidance where slope exceeds 5%.
3. Once the unit is set, the internal wooden forms and protective silt fabric cover must be left intact (if WetlandMedia pre-installed). The top lid(s) should be sealed onto the box section before backfilling, using a non-shrink grout, butyl rubber or similar waterproof seal. The boards on the top of the lid and boards sealed in the unit's throat must NOT be removed. The Supplier will remove these sections at the time of activation.
4. Outlet connections shall be aligned and sealed to meet the approved drawings with modifications necessary to meet site conditions and local regulations. The correct outlet will be marked on the Modular Wetland unit.
5. Backfilling should be performed in a careful manner, bringing the appropriate fill material up in 6-inch lifts on all sides. Precast sections shall be set in a manner that will result in a watertight joint. In all instances, installation of the Modular Wetland unit shall conform to ASTM specification C891 "Standard Practice for Installation of Underground Precast Utility Structures" unless specified otherwise in contract documents.
6. It is the responsibility of the Contractor to provide curb and gutter and transition to the Modular Wetland unit for proper stormwater flow into the system through the throat, pipe or grate opening. A standard drawing of the throat and gutter detail is available in the following section; however the plans and contract documents supersede all standard drawings. Several variations of the standard design are available. Effective bypass for the Modular Wetland System is essential for correct operation (i.e. bypass to an overflow at lower elevation).

## Installation Procedure

A set of lifting hooks, shackles, knuckles and eye bolts are provided by Modular Wetlands with the first delivery of every project.

The contractor **MUST** provide all rigging And lifting apparatus, such as all cables and chains or straps.



It is the contractor's responsibility to provide suitable lifting equipment to off-load the Modular Wetland unit.

Modular Wetland units are designed to be off-loaded using the contractor's spreader bar.



### 1. Apply Butyl Tape Seal

Apply butyl tape seal along the top of the box section. Butyl tape seal is provided with every unit.

Modular Wetland installed protective throat board and installed silt fabric must be left in place to protect the unit from construction sediment.



## 2. Unload and Set Box

Unload the Modular Wetland unit  
the prepared hole with appropriate sub-grade.\*

\* Compacted sub-grade with a minimum  
of six inches of gravel base which must match  
the final grade of curb line the area of the unit.



## 3. Set Top On Box

Set the top slab on the box.

The Contractor is responsible for providing  
adequate and complete site/inlet protection  
when the Modular Wetland is installed prior  
to final site stabilization (full landscaping,  
grass cover, final paving, and street sweeping  
completed).



## 4. Connect Outfall Pipe

The correct outlet will be marked on the  
Modular Wetland.

Invert of outlet pipe **MUST** be even  
with the floor of the system.



## **5. Install Curb & Gutter**

It is the responsibility of the Contractor to provide curb and gutter and transition to the Modular Wetland for proper flow into the system through a 5" - 7" throat opening. A standard drawing of the throat and gutter detail in the following section. CONTRACTOR RESPONSIBLE FOR GROUTING IN ANY VISIBLE LIFTING POINTS.



## **6. Activation**

Activation is performed **ONLY** by Modular Wetland personnel.

Activation can occur once the project site is fully stabilized (full landscaping, grass cover, final paving and street sweeping completed) and there is a 5" - 7" throat opening.

Call 760-433-7640 to schedule your activation.



## **NOTE: WetlandMedia Installation**

For Larger models (MWS-L-4-13 and above) the system will be delivered without WetlandMedia pre-installed to minimize pick weight and prevent contamination of the media during construction. For these models the WetlandMedia will be delivered in bulk or in super sacks. It will be responsibility of the contractor to fill the system with the WetlandMedia during the installation process. Installation of the WetlandMedia can be done after the unit is fully installed to avoid contamination. See following pages for details.

# WetlandMedia Install (if applicable)



## 1. Fill WetlandMedia

Position super sack of WetlandMedia over wetland chamber. Bottom of sack should not be more than 2' above top of system. Open sack and fill evenly\*.

\* One to several hundred cubic yards of WetlandMedia will be required based upon the model number and size of the system. For large scale jobs WetlandMedia will be delivered in bulk and will require a bobcat or similar to fill the system. All equipment is the responsibility of the contractor.



## 2. Install Plant Propagation Layer

Fill WetlandMedia up to 9" below the top of the wetland chamber. Level out the WetlandMedia as shown. Ensure that the level does not vary more than one inch or plant growth will be affected.



## 3. Install Plant Propagation Layer

Utilize plant propagation blocks provided by the manufacturer. Each block is approximately 40" by 6" by 3" thick. Blocks shall be placed side by side and end to end and cover the entire length and width of the wetland chamber unless specified.



#### **4. Finish Filling WetlandMedia**

After plant propagation blocks are installed repeat step 1 and fill the system to the top of the wetland chamber as shown. WetlandMedia must be filled within 2" of the top of the unit.



#### **5. Planting**

After system is filled with WetlandMedia planting of vegetation can begin. Utilizing 1 gallon plants dig down until The plant propagation blocks are reached. Remove plant and it's root ball from the container. Set the bottom of the root ball on the tops of the blocks. Fill hole back in with WetlandMedia. After planting a thorough watering of the plants is necessary. The plant propagation blocks must be saturated to provide a water source for the plants during the establishment phase. It is recommended that hand watering is done three times a week for the first two months. Hand water can be supplemented with drip or spray irrigation after the second week. Please call the manufacturer for more details on plants, planting arrangement and irrigation options.

**NOTE: planting is required on all units, including units delivered with WetlandMedia pre-installed.**



## Curb and Gutter Details



**Modular Wetland System, Inc.**

**P. 760.433-7640**

**F. 760-433-3176**

**E. [Info@modularwetlands.com](mailto:Info@modularwetlands.com)**

**[www.modularwetlands.com](http://www.modularwetlands.com)**

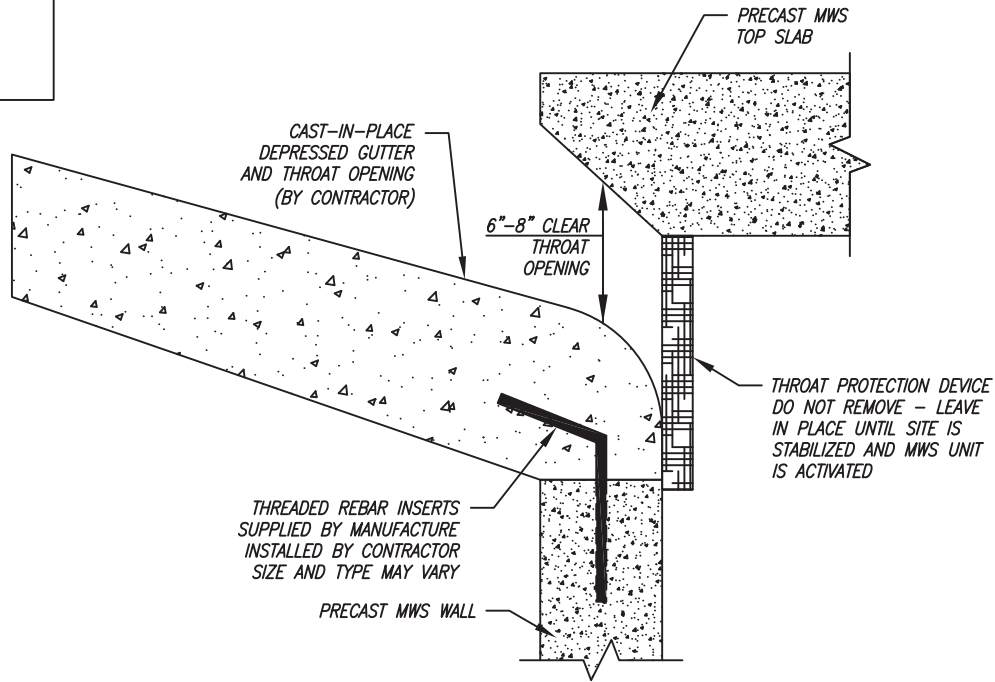

SECTION VIEW  
STANDARD MODULAR WETLAND CURB OPENING

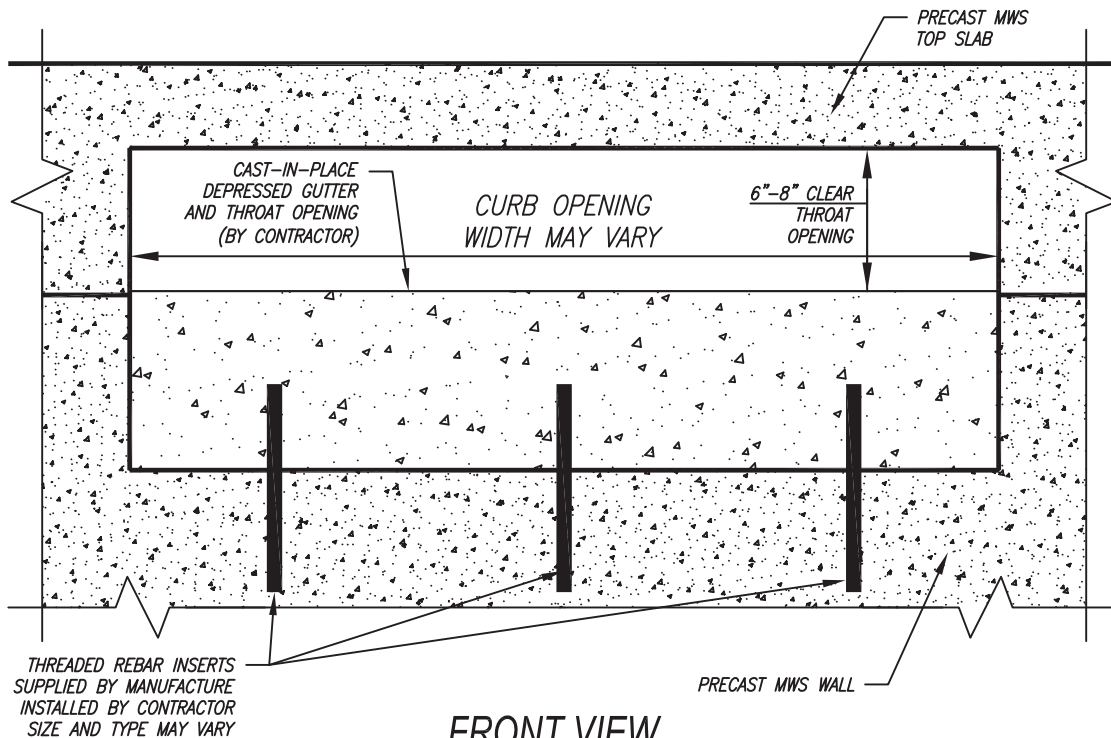

FRONT VIEW  
STANDARD MODULAR WETLAND CURB OPENING

MODULAR WETLAND SYSTEMS INC.  
P.O. BOX 869  
OCEANSIDE, CA 92049  
www.ModularWetlands.com

	NAME	DATE
DRAWN	John	5/3/13
EDITED		

TITLE: MWS LINEAR 2.0  
CURB INLET DETAILS

PROPRIETARY AND CONFIDENTIAL  
THE INFORMATION CONTAINED IN THIS DRAWING IS THE SOLE PROPERTY OF MODULAR WETLAND SYSTEMS INC. ANY REPRODUCTION IN PART OR AS A WHOLE WITHOUT THE WRITTEN PERMISSION OF MODULAR WETLAND SYSTEMS INC. IS PROHIBITED.

COMMENTS:

SIZE	DWG. NO.	REV
SCALE	NTS	UNITS = INCHES
		SHEET 1 OF 1

## Weights and Lifting Details



**Modular Wetland System, Inc.**

**P. 760.433-7640**

**F. 760-433-3176**

**E. [Info@modularwetlands.com](mailto:Info@modularwetlands.com)**

**[www.modularwetlands.com](http://www.modularwetlands.com)**

## MWS-L 2.0 Max Pick Weights

Model #	Size (O.D)	Size (I.D)	Unit Weight (lbs)	Media Weight (lbs)	Total Weight (lbs)
MWS-L-4-4	5' x 5'	4' x 4'	7500.0	1447.1	8947.1
MWS-L-4-6 MWS-L-4-6.5	5' x 7' 5' x 7.5'	4' x 6' 4' x 6.5'	11,000 11,500	1619.2	12,619.2 13,119.2
MWS-L-4-8	5' x 9'	8' x 4'	12500	3570	16070
MWS-L-4-13	5' x 14'	13' x 4'	21200	5306	26506
MWS-L-4-15	5' x 16'	15' x 4'	23700	7236	30936
MWS-L-4-17	5' x 18'	17' x 4'	26500	9165	35665
MWS-L-4-19	5' x 20'	19' x 4'	28300	11095	39395
MWS-L-4-21	5' x 22'	21' x 4'	30000	13024	43024

Max Pick Weight if Shipped  
Without Media Installed

Max Pick Weight if  
Shipped With Media  
Installed

Note: All weights listed hereon are standard max pick weights, actual pick weights may vary based upon state and local regulations and variation in concrete and rebar standards. For project specific pick weights contact the manufacturer prior to shipping of the unit(s). It is the contractor's responsibility to off-load the unit with an adequate size crane. Units are shipped with WetlandMEDIA in superbags and installed by contractor.

When Available see project contract terms, if lifting points are on the inside of the unit due to custom designs or installations requiring points to be on the inside the media will be shipped in bags and the contractor will be responsible to install after the unit is installed. For example, units placed against a wall.

For Questions or Comments Please Call 760-433-7640 or email: [info@modularwetlands.com](mailto:info@modularwetlands.com)



## Connection Details



**Modular Wetland System, Inc.**

**P. 760.433-7640**

**F. 760-433-3176**

**E. [Info@modularwetlands.com](mailto:Info@modularwetlands.com)**

**[www.modularwetlands.com](http://www.modularwetlands.com)**

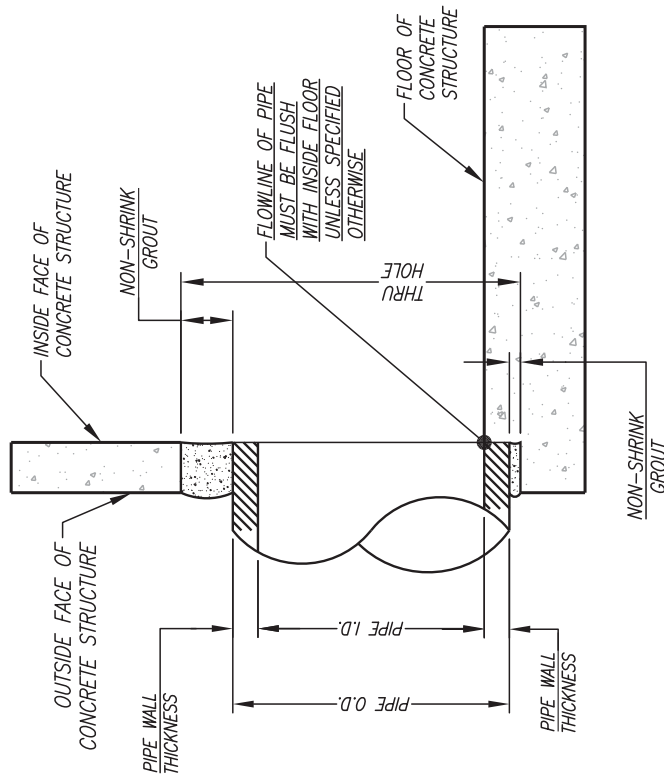

## ELEVATION VIEW

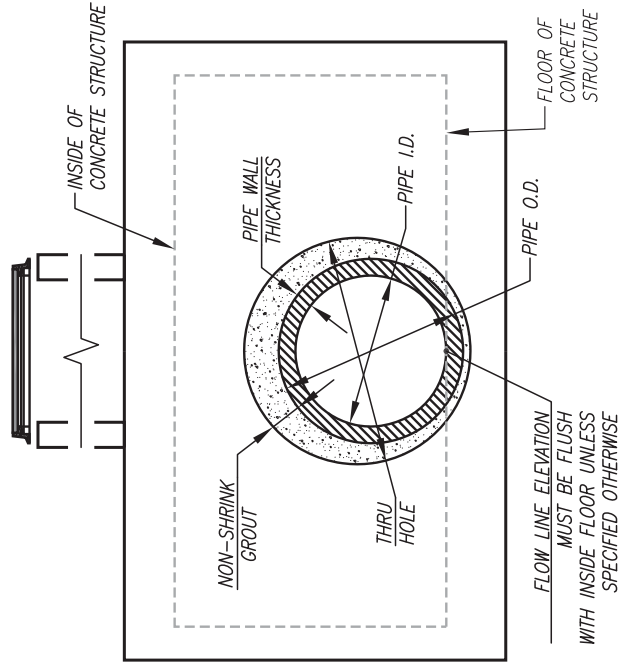

## END VIEW

### INSTALLATION NOTES

1. ALL CONNECTION PIPES SUPPLIED AND INSTALLED BY CONTRACTOR. MODULAR WETLAND UNIT WILL BE DELIVERED WITH A THRU HOLE AND ITS THE CONTRACTORS RESPONSIBILITY TO SUPPLY PIPE, AND ALL LABOR AND MATERIAL TO CONNECT PIPE AND SEAL UNIT WATER TIGHT INCLUDING BUT NOT LIMITED TO GROUT, CONCRETE LUG, REBAR, PLUG, ANCHORS, COUPLER, FITTINGS AND/OR ALL SUPPORT AND CONNECTING HARDWARE.
2. ALL CONNECTIONS ARE TO BE FLUSH WITH THE INSIDE SURFACE OF THE CONCRETE STRUCTURE. (CAN NOT INTRUDE BEYOND FLUSH) ALL PIPE FLOWLINES SHALL BE FLUSH WITH INSIDE FLOOR UNLESS SPECIFIED OTHERWISE.
3. ALL GROUT AND/OR CONCRETE SHALL BE NON-SHRINK AND MEET OR EXCEED LOCAL PIPE CONNECTION STANDARDS.
4. REFER TO AGENCY SPECIFICATIONS WHERE APPLICABLE.

THE PRODUCT DESCRIBED MAY BE PROTECTED BY ONE OR MORE OF THE FOLLOWING US PATENTS: 7,425,262; 7,470,862; 7,674,378; 8,303,816. RELATED FOREIGN PATENTS OR OTHER PATENTS PENDING

PROPRIETARY AND CONFIDENTIAL:

THE INFORMATION CONTAINED IN THIS DRAWING IS THE SOLE PROPERTY OF MODULAR WETLANDS SYSTEMS. ANY REPRODUCTION IN PART OR AS A WHOLE WITHOUT THE WRITTEN PERMISSION OF MODULAR WETLANDS SYSTEMS IS PROHIBITED.

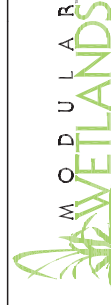

PIPE CONNECTION  
STANDARD DETAIL

# MWS Linear 2.0 HGL Sizing Calculations



MWS MODEL SIZE	WETLAND PERMITTER LENGTH	LOADING RATE GPM/SF	HGL HEIGHT																																	
			SHALLOW MODELS																													STANDARD HEIGHT MODEL	HIGH CAPACITY MODELS			
			1.4	1.5	1.6	1.7	1.8	1.9	2.0	2.1	2.2	2.3	2.4	2.5	2.6	2.7	2.8	2.9	3.0	3.1	3.2	3.3	3.4	3.5	3.6	3.65	3.70	3.75	3.80	3.85	3.90		3.95			
MWS-L-4-4	6.70	1.0	0.022	0.023	0.025	0.026	0.028	0.029	0.031	0.032	0.034	0.035	0.037	0.038	0.040	0.042	0.043	0.045	0.046	0.048	0.049	0.051	0.052	0.054	0.055	0.056	0.057	0.058	0.058	0.059	0.060	0.061				
MWS-L-4-6	9.10	1.0	0.029	0.031	0.033	0.036	0.038	0.040	0.042	0.044	0.046	0.048	0.050	0.052	0.054	0.056	0.058	0.061	0.063	0.065	0.067	0.069	0.071	0.073	0.075	0.076	0.077	0.078	0.079	0.080	0.081	0.082				
MWS-L-4-8	14.80	1.0	0.048	0.051	0.054	0.058	0.061	0.065	0.068	0.071	0.075	0.078	0.082	0.085	0.088	0.092	0.095	0.099	0.102	0.105	0.109	0.112	0.115	0.119	0.122	0.124	0.126	0.127	0.129	0.131	0.132	0.134				
MWS-L-4-13	18.40	1.0	0.059	0.063	0.068	0.072	0.076	0.080	0.084	0.089	0.093	0.097	0.101	0.106	0.110	0.114	0.118	0.122	0.127	0.131	0.135	0.139	0.144	0.148	0.152	0.154	0.156	0.158	0.160	0.163	0.165	0.167				
MWS-L-4-15	22.40	1.0	0.072	0.077	0.082	0.087	0.093	0.098	0.103	0.108	0.113	0.118	0.123	0.129	0.134	0.139	0.144	0.149	0.154	0.159	0.165	0.170	0.175	0.180	0.185	0.188	0.190	0.193	0.195	0.198	0.200	0.203				
MWS-L-4-17	26.40	1.0	0.085	0.091	0.097	0.103	0.109	0.115	0.121	0.127	0.133	0.139	0.145	0.151	0.158	0.164	0.170	0.176	0.182	0.188	0.194	0.200	0.206	0.212	0.218	0.221	0.224	0.227	0.230	0.233	0.236	0.239				
MWS-L-4-19	30.40	1.0	0.098	0.105	0.112	0.119	0.126	0.133	0.140	0.147	0.153	0.160	0.167	0.174	0.181	0.188	0.195	0.202	0.209	0.216	0.223	0.230	0.237	0.244	0.251	0.255	0.258	0.262	0.265	0.269	0.272	0.276				
MWS-L-4-21	34.40	1.0	0.111	0.118	0.126	0.134	0.142	0.150	0.158	0.166	0.174	0.182	0.189	0.197	0.205	0.213	0.221	0.229	0.237	0.245	0.253	0.261	0.268	0.276	0.284	0.288	0.292	0.296	0.300	0.304	0.308	0.312				
MWS-L-8-12	44.40	1.0	0.143	0.153	0.163	0.173	0.183	0.194	0.204	0.214	0.224	0.234	0.245	0.255	0.265	0.275	0.285	0.296	0.306	0.316	0.326	0.336	0.346	0.357	0.367	0.372	0.377	0.382	0.387	0.392	0.397	0.402				
MWS-L-8-16	59.20	1.0	0.190	0.204	0.217	0.231	0.245	0.258	0.272	0.285	0.299	0.312	0.326	0.340	0.353	0.367	0.380	0.394	0.408	0.421	0.435	0.448	0.462	0.476	0.489	0.496	0.503	0.509	0.516	0.523	0.530	0.537				

## Maintenance Guidelines for Modular Wetland System - Linear

### Maintenance Summary

- Remove Trash from Screening Device – average maintenance interval is 6 to 12 months.
  - *(5 minute average service time).*
- Remove Sediment from Separation Chamber – average maintenance interval is 12 to 24 months.
  - *(10 minute average service time).*
- Replace Cartridge Filter Media – average maintenance interval 12 to 24 months.
  - *(10-15 minute per cartridge average service time).*
- Replace Drain Down Filter Media – average maintenance interval is 12 to 24 months.
  - *(5 minute average service time).*
- Trim Vegetation – average maintenance interval is 6 to 12 months.
  - *(Service time varies).*

### System Diagram

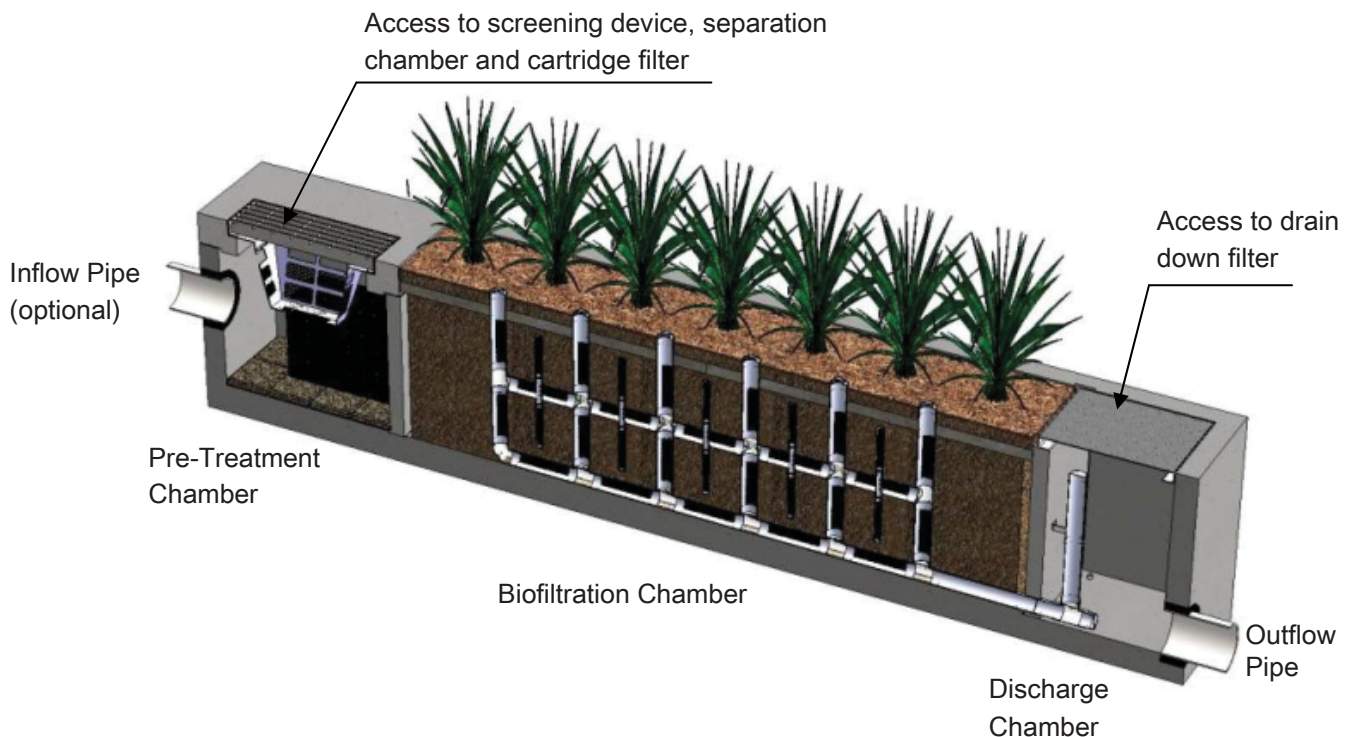

# Maintenance Procedures

## Screening Device

1. Remove grate or manhole cover to gain access to the screening device in the Pre-Treatment Chamber. Vault type units do not have screening device. Maintenance can be performed without entry.
2. Remove all pollutants collected by the screening device. Removal can be done manually or with the use of a vacuum truck. The hose of the vacuum truck will not damage the screening device.
3. Screening device can easily be removed from the Pre-Treatment Chamber to gain access to separation chamber and media filters below. Replace grate or manhole cover when completed.

## Separation Chamber

1. Perform maintenance procedures of screening device listed above before maintaining the separation chamber.
2. With a pressure washer spray down pollutants accumulated on walls and cartridge filters.
3. Vacuum out Separation Chamber and remove all accumulated pollutants. Replace screening device, grate or manhole cover when completed.

## Cartridge Filters

1. Perform maintenance procedures on screening device and separation chamber before maintaining cartridge filters.
2. Enter separation chamber.
3. Unscrew the two bolts holding the lid on each cartridge filter and remove lid.
4. Remove each of 4 to 8 media cages holding the media in place.
5. Spray down the cartridge filter to remove any accumulated pollutants.
6. Vacuum out old media and accumulated pollutants.
7. Reinstall media cages and fill with new media from manufacturer or outside supplier. Manufacturer will provide specification of media and sources to purchase.
8. Replace the lid and tighten down bolts. Replace screening device, grate or manhole cover when completed.

## Drain Down Filter

1. Remove hatch or manhole cover over discharge chamber and enter chamber.
2. Unlock and lift drain down filter housing and remove old media block. Replace with new media block. Lower drain down filter housing and lock into place.
3. Exit chamber and replace hatch or manhole cover.



## Maintenance Notes

1. Following maintenance and/or inspection, it is recommended the maintenance operator prepare a maintenance/inspection record. The record should include any maintenance activities performed, amount and description of debris collected, and condition of the system and its various filter mechanisms.
2. The owner should keep maintenance/inspection record(s) for a minimum of five years from the date of maintenance. These records should be made available to the governing municipality for inspection upon request at any time.
3. Transport all debris, trash, organics and sediments to approved facility for disposal in accordance with local and state requirements.
4. Entry into chambers may require confined space training based on state and local regulations.
5. No fertilizer shall be used in the Biofiltration Chamber.
6. Irrigation should be provided as recommended by manufacturer and/or landscape architect. Amount of irrigation required is dependent on plant species. Some plants may require irrigation.

## Maintenance Procedure Illustration

### Screening Device

The screening device is located directly under the manhole or grate over the Pre-Treatment Chamber. It's mounted directly underneath for easy access and cleaning. Device can be cleaned by hand or with a vacuum truck.



### Separation Chamber

The separation chamber is located directly beneath the screening device. It can be quickly cleaned using a vacuum truck or by hand. A pressure washer is useful to assist in the cleaning process.



### Cartridge Filters

The cartridge filters are located in the Pre-Treatment chamber connected to the wall adjacent to the biofiltration chamber. The cartridges have removable tops to access the individual media filters. Once the cartridge is open media can be easily removed and replaced by hand or a vacuum truck.



### Drain Down Filter

The drain down filter is located in the Discharge Chamber. The drain filter unlocks from the wall mount and hinges up. Remove filter block and replace with new block.



### Trim Vegetation

Vegetation should be maintained in the same manner as surrounding vegetation and trimmed as needed. No fertilizer shall be used on the plants. Irrigation per the recommendation of the manufacturer and or landscape architect. Different types of vegetation requires different amounts of irrigation.





## Inspection Form



**Modular Wetland System, Inc.**

**P. 760.433-7640**

**F. 760-433-3176**

**E. [Info@modularwetlands.com](mailto:Info@modularwetlands.com)**

**[www.modularwetlands.com](http://www.modularwetlands.com)**



# Inspection Report Modular Wetlands System



Project Name \_\_\_\_\_

Project Address \_\_\_\_\_ (city) (Zip Code)

Owner / Management Company \_\_\_\_\_

Contact \_\_\_\_\_

Phone ( ) -

Inspector Name \_\_\_\_\_

Date \_\_\_\_ / \_\_\_\_ / \_\_\_\_

Time \_\_\_\_\_ AM / PM

Type of Inspection  Routine  Follow Up  Complaint

Storm

Storm Event in Last 72-hours?  No  Yes

Weather Condition \_\_\_\_\_

Additional Notes \_\_\_\_\_

For Office Use Only

---

(Reviewed By) \_\_\_\_\_

---

(Date) \_\_\_\_\_  
Office personnel to complete section to the left.

### Inspection Checklist

Modular Wetland System Type (Curb, Grate or UG Vault): \_\_\_\_\_ Size (22', 14' or etc.): \_\_\_\_\_

Structural Integrity:	Yes	No	Comments
Damage to pre-treatment access cover (manhole cover/grate) or cannot be opened using normal lifting pressure?			
Damage to discharge chamber access cover (manhole cover/grate) or cannot be opened using normal lifting pressure?			
Does the MWS unit show signs of structural deterioration (cracks in the wall, damage to frame)?			
Is the inlet/outlet pipe or drain down pipe damaged or otherwise not functioning properly?			
<b>Working Condition:</b>			
Is there evidence of illicit discharge or excessive oil, grease, or other automobile fluids entering and clogging the unit?			
Is there standing water in inappropriate areas after a dry period?			
Is the filter insert (if applicable) at capacity and/or is there an accumulation of debris/trash on the shelf system?			
Does the depth of sediment/trash/debris suggest a blockage of the inflow pipe, bypass or cartridge filter? If yes, specify which one in the comments section. Note depth of accumulation in in pre-treatment chamber.			Depth:
Does the cartridge filter media need replacement in pre-treatment chamber and/or discharge chamber?			Chamber:
Any signs of improper functioning in the discharge chamber? Note issues in comments section.			
<b>Other Inspection Items:</b>			
Is there an accumulation of sediment/trash/debris in the wetland media (if applicable)?			
Is it evident that the plants are alive and healthy (if applicable)? Please note Plant Information below.			
Is there a septic or foul odor coming from inside the system?			

Waste:	Yes	No
Sediment / Silt / Clay		
Trash / Bags / Bottles		
Green Waste / Leaves / Foliage		

Recommended Maintenance	
No Cleaning Needed	
Schedule Maintenance as Planned	
Needs Immediate Maintenance	

Plant Information	
Damage to Plants	
Plant Replacement	
Plant Trimming	

Additional Notes: \_\_\_\_\_

## Maintenance Report



**Modular Wetland System, Inc.**

**P. 760.433-7640**

**F. 760-433-3176**

**E. [Info@modularwetlands.com](mailto:Info@modularwetlands.com)**

**[www.modularwetlands.com](http://www.modularwetlands.com)**



# Cleaning and Maintenance Report Modular Wetlands System



Project Name \_\_\_\_\_

Project Address \_\_\_\_\_

(city) (Zip Code)

Owner / Management Company \_\_\_\_\_

Contact \_\_\_\_\_

Phone ( ) -

Inspector Name \_\_\_\_\_

Date \_\_\_\_ / \_\_\_\_ / \_\_\_\_ Time \_\_\_\_ AM / PM

Type of Inspection  Routine  Follow Up  Complaint

Storm Storm Event in Last 72-hours?  No  Yes

Weather Condition \_\_\_\_\_

Additional Notes \_\_\_\_\_

For Office Use Only

---

(Reviewed By)

---

(Date)  
Office personnel to complete section to the left.

Site Map #	GPS Coordinates of Insert	Manufacturer / Description / Sizing	Trash Accumulation	Foliage Accumulation	Sediment Accumulation	Total Debris Accumulation	Condition of Media 25/50/75/100 (will be changed @ 75%)	Operational Per Manufactures' Specifications (If not, why?)
	Lat: Long:	MWS Catch Basins						
		MWS Sedimentation Basin						
		Media Filter Condition						
		Plant Condition						
		Drain Down Media Condition						
		Discharge Chamber Condition						
		Drain Down Pipe Condition						
		Inlet and Outlet Pipe Condition						

Comments:

---



---



## Section [ \_\_\_\_\_ ] Modular Subsurface Flow Wetland System

### **PART 1 – GENERAL**

#### 01.01.00 Purpose

The purpose of this specification is to establish generally acceptable criteria for Modular Subsurface Flow Wetland Systems used for biofiltration of stormwater runoff including dry weather flows and other contaminated water sources. It is intended to serve as a guide to producers, distributors, architects, engineers, contractors, plumbers, installers, inspectors, agencies and users; to promote understanding regarding materials, manufacture and installation; and to provide for identification of devices complying with this specification.

#### 01.02.00 Description

Modular Subsurface Flow Wetland Systems (MSFWS) are used for filtration of stormwater runoff including dry weather flows. The MSFWS is a pre-engineered biofiltration system composed of a pretreatment chamber containing filtration cartridges, a horizontal flow biofiltration chamber with a peripheral void area and a centralized and vertically extending underdrain, the biofiltration chamber containing a sorptive media mix which does not contain any organic material and a layer of plant establishment media, and a discharge chamber containing an orifice control structure. Treated water flows horizontally in series through the pretreatment chamber cartridges, biofiltration chamber and orifice control structure.

#### 01.03.00 Manufacturer

The manufacturer of the MSFWS shall be one that is regularly engaged in the engineering design and production of systems developed for the treatment of stormwater runoff for at least (10) years, and which have a history of successful production, acceptable to the engineer of work. In accordance with the drawings, the MSFWS(s) shall be a filter device Manufactured by Bio Clean Environmental Services, Inc., or Modular Wetland Systems, Inc., or assigned distributors or licensees. Bio Clean Environmental Services Inc., and Modular Wetland Systems, Inc., can be reached at:

Corporate Headquarters:  
Bio Clean Environmental Service, Inc.  
2972 San Luis Rey Road  
Oceanside, CA 92058  
Phone: (760) 433-7640  
Fax: (760) 433-3176  
[www.biocleanenvironmental.net](http://www.biocleanenvironmental.net)

Corporate Headquarters:  
Modular Wetland Systems, Inc.  
P.O. Box 869  
Oceanside, CA 92049  
Phone: (760) 433-7650  
[www.modularwetlands.net](http://www.modularwetlands.net)



01.04.00 Submittals

- 01.04.01 Shop drawings are to be submitted with each order to the contractor and consulting engineer.
- 01.04.02 Shop drawings are to detail the MSFWS and all components required and the sequence for installation, including:
  - System configuration with primary dimensions
  - Interior components
  - Any accessory equipment called out on shop drawings
- 01.04.03 Inspection and maintenance documentation submitted upon request.

01.05.00 Work Included

- 01.05.01 Specification requirements for installation of MSFWS.
- 01.05.02 Manufacturer to supply components of the MSFWS(s):
  - Pretreatment chamber components (pre-assembled)
  - Concrete Structure(s)
  - Biofiltration chamber components (pre-assembled)
  - Flow control discharge structure (pre-assembled)

01.06.00 Reference Standards

ASTM C 29	Standard Test Method for Unit Weight and Voids in Aggregate
ASTM C 88	C 88 Standard Test Method for Soundness of Aggregates by Use of Sodium Sulfate or Magnesium Sulfate
ASTM C131	C 131 Standard Test Method for Resistance to Degradation of Small-Size Coarse Aggregates by Abrasion and Impact in the Los Angeles Machine
ASTM C 136	C 136 Standard Test Method for Sieve Analysis of Fine and Coarse Aggregates
ASTM C 330	C 330 Standard Specification for Lightweight Aggregate for Structural Concrete
ASTM D 698	Test Method for Laboratory Compaction Characteristics of Soil Using Standard Effort (12,400 ft.-lbf/ft <sup>3</sup> (600 kN-m/m <sup>3</sup> ))
ASTM D 1621	10 Standard Test Method for Compressive Properties Of Rigid Cellular Plastics
ASTM D 1777	ASTM D1777 - 96(2007) Standard Test Method for Thickness of Textile Materials
ASTM D 4716	Standard Test Method for Determining the (In-plane) Flow Rate per Unit Width and Hydraulic Transmissivity of a Geosynthetic Using a Constant Head
AASHTO T 99-01	Standard Method of Test for Moisture-Density Relations of Soils Using a 2.5-kg (5.5-lb) Rammer and a 305-mm (12-in) Drop
AASHTO T 104	Standard Method of Test for Soundness of Aggregate by Use of Sodium Sulfate or Magnesium Sulfate
AASHTO T 260	Standard Method of Test for Sampling and Testing for Chloride Ion in Concrete and Concrete Raw Materials.
AASHTO T 288	Standard Method of Test for Determining Minimum Laboratory Soil Resistivity
AASHTO T 289	Standard Method of Test for Determining ph of Soil for Use in Corrosion Testing
AASHTO T 291	Standard Method of Test for Determining Water Soluble Chloride Ion Content in Soil
AASHTO T 290	T 290 Standard Method of Test for Determining Water Soluble Sulfate Ion Content in Soil



## **PART 2 – COMPONENTS**

The Modular Subsurface Flow Wetland Systems (MSFWS) and all of its components shall be self-contained within a concrete structure constructed of concrete with a minimum 28 day compressive strength of 5,000 psi, with reinforcing per ASTM A 615, Grade 60, and supports and H2O loading as indicated by AASHTO. Each Chamber shall have appropriate access hatches for easy maintenance and sized to allow removal of all internal components without disassembly. All water transfer system components shall conform with the following;

- Filter netting shall be 100% Polyester with a number 16 sieve size, and strength tested per ASTM D 3787.
- Drainage cells shall be manufactured of lightweight injection-molded plastic and have a minimum compressive strength test of 6,000 psi and a void area along the surface making contact with the filter media of 75% or greater. The cells shall be at least 2" in thickness and allow water to freely flow in all four directions.

### **02.01.00 Pretreatment Chamber Components**

02.01.01 Filter Cartridges shall operate at a loading rate not to exceed 3 gallons per minute per square foot surface area.

02.01.02 Drain Down System shall include a pervious floor that allows water to drain into the underdrain pipe that is connected to the discharge chamber.

### **02.02.00 Biofiltration Chamber Components**

02.02.01 Media shall consist of ceramic material produced by expanding and vitrifying select material in a rotary kiln. Media must be produced to meet the requirements of ASTM C330, ASTM C331, and AASHTO M195. Aggregates must have a minimum 24-hour water absorption of 10.5% mass. Media shall not contain any organic material. Flow through media shall be horizontal from the outer perimeter of the chamber toward the centralized and vertically extending underdrain. The retention time in the media shall be at least 3 minutes. Downward flow filters are not acceptable alternatives. The thickness of the media shall be at least 19" from influent end to effluent end. The loading rate on the media shall not exceed 1.1 gallons per minute per square foot surface area. Media must be contained within structure that spaces the surface of the media at least 2" from all vertically extending walls of the concrete structure.

02.02.02 Planting shall be native, drought tolerant species recommend by manufacturer and/or landscape architect.

02.02.03 Plant Support Media shall be made of a 3" thick moisture retention cell that is inert and contains no chemicals or fertilizers, is not made of organic material and has an internal void percentage of 80%.

### **02.03.00 Discharge Chamber**

The discharge device shall house a flow control orifice plate that restricts flows greater than designed treatment flow rate. All piping components shall be made of a high-density polyethylene. The discharge chamber shall also contain a drain down filter if specified on the drawing.



## **PART 3 – PERFORMANCE**

### **03.01.00 General**

- 03.01.01 Function - The MSFWS has no moving internal components and functions based on gravity flow, unless otherwise specified. The MSFWS is composed of a pretreatment chamber, a biofiltration chamber and a discharge chamber. The pretreatment device houses cartridge media filters, which consist of filter media housed in a perforated enclosure. The untreated runoff flows into the system via subsurface piping and or surface inlet. Water entering the system is forced through the filter cartridge enclosures by gravity flow. Then the flow contacts the filter media. The flow through the media is horizontal toward the center of each individual media filter. In the center of the media shall be a round slotted PVC pipe of no greater than 1.5” in diameter. The slotted PVC pipe shall extend downward into the water transfer cavity of the cartridge. The slotted PVC pipe shall be threaded on the bottom to connect to the water transfer cavity. After pollutants have been removed by the filter media the water discharges the pretreatment chamber and flows into the water transfer system and is conveyed to the biofiltration chamber. Once runoff has been filtered by the biofiltration chamber it is collected by the vertical underdrain and conveyed to a discharge chamber equipped with a flow control orifice plate. Finally the treated flow exits the system.
- 03.01.02 Pollutants - The MSFWS will remove and retain debris, sediments, TSS, dissolved and particulate metals and nutrients including nitrogen and phosphorus species, bacteria, BOD, oxygen demanding substances, organic compounds and hydrocarbons entering the filter during frequent storm events and continuous dry weather flows.
- 03.01.03 Treatment Flow Rate and Bypass - The MSFWS operates in-line. The MSFWS will treat 100% of the required water quality treatment flow based on a minimum filtration capacities listed in section 03.02.00. The size of the system must match those provided on the drawing to ensure proper performance and hydraulic residence time.

#### Minimum Treatment Capabilities

- System must be capable of treating flows to the specified treatment flow rate on the drawings. The flow rate shall be controlled by an orifice plate.

## **PART 4 - EXECUTION**

### **04.01.00 General**

The installation of the MSFWS shall conform to all applicable national, state, state highway, municipal and local specifications.

### **04.02.00 Installation**

The Contractor shall furnish all labor, equipment, materials and incidentals required to install the (MSFWS) device(s) and appurtenances in accordance with the drawings and these specifications.



- 04.02.01 Grading and Excavation site shall be properly surveyed by a registered professional surveyor, and clearly marked with excavation limits and elevations. After site is marked it is the responsibility of the contractor to contact local utility companies and/or DigAlert to check for underground utilities. All grading permits shall be approved by governing agencies before commencement of grading and excavation. Soil conditions shall be tested in accordance with the governing agencies requirements. All earth removed shall be transported, disposed, stored, and handled per governing agencies standards. It is the responsibility of the contractor to install and maintain proper erosion control measures during grading and excavation operations.
- 04.02.02 Compaction – All soil shall be compacted per registered professional soils engineer’s recommendations prior to installation of MSFWS components.
- 04.02.03 Backfill shall be placed according to a registered professional soils engineer’s recommendations, and with a minimum of 6” of gravel under all concrete structures.
- 04.02.04 Concrete Structures – After backfill has been inspected by the governing agency and approved the concrete structures shall be lifted and placed in proper position per plans.
- 04.02.05 Subsurface Flow Wetland Media shall be carefully loaded into area so not to damage the Wetland Liner or Water Transfer Systems. The entire wetland area shall be filled to a level 9 inches below finished surface.
- 04.02.06 Planting layer shall be installed per manufacturer’s drawings and consist of a minimum 3” grow enhancement media that ensures greater than 95% plant survival rate, and 6” of wetland media. Planting shall consist of native plants recommended by manufacturer and/or landscape architect. Planting shall be drip irrigated for at least the first 3 months to insure long term plant growth. No chemical herbicides, pesticides, or fertilizers shall be used in the planting or care and maintenance of the planted area.

#### 04.03.00 Shipping, Storage and Handling

- 04.03.01 Shipping – MSFWS shall be shipped to the contractor’s address or job site, and is the responsibility of the contractor to offload the unit(s) and place in the exact site of installation.
- 04.03.02 Storage and Handling– The contractor shall exercise care in the storage and handling of the MSFWS and all components prior to and during installation. Any repair or replacement costs associated with events occurring after delivery is accepted and unloading has commenced shall be born by the contractor. The MSFWS(s) and all components shall always be stored indoors and transported inside the original shipping container until the unit(s) are ready to be installed. The MSFWS shall always be handled with care and lifted according to OSHA and NIOSA lifting recommendations and/or contractor’s workplace safety professional recommendations.

#### 04.04.00 Maintenance and Inspection

- 04.04.01 Inspection – After installation, the contractor shall demonstrate that the MSFWS has been properly installed at the correct location(s), elevations, and with appropriate components. All components associated with the MSFWS and its installation shall be subject to inspection by the engineer at the place of installation. In addition, the contractor shall demonstrate that the MSFWS has been installed per the manufacturer’s specifications and recommendations. All



- components shall be inspected by a qualified person once a year and results of inspection shall be kept in an inspection log.
- 04.04.02 Maintenance – The manufacturer recommends cleaning and debris removal maintenance of once a year and replacement of the Cartridge Filters as needed. The maintenance shall be performed by someone qualified. A Maintenance Manual is available upon request from the manufacturer. The manual has detailed information regarding the maintenance of the MSFWS. A Maintenance/Inspection record shall be kept by the maintenance operator. The record shall include any maintenance activities performed, amount and description of debris collected, and the condition of the filter.
- 04.04.03 Material Disposal - All debris, trash, organics, and sediments captured by the MSFWS shall be transported and disposed of at an approved facility for disposal in accordance with local and state requirements. Please refer to state and local regulations for the proper disposal of toxic and non-toxic material.

## **PART 5 – QUALITY ASSURANCE**

### **05.01.00 Warranty**

The Manufacturer shall guarantee the MSFWS against all manufacturing defects in materials and workmanship for a period of (5) years from the date of delivery to the \_\_\_\_\_. The manufacturer shall be notified of repair or replacement issues in writing within the warranty period. The MSFWS is limited to recommended application for which it was designed.

### **05.02.00 Performance Certification**

The MSFWS manufacturer shall submit to the Engineer of Record a “Manufacturer’s Performance Certificate” certifying the MSFWS is capable of achieving the specified removal efficiency for suspended solids, phosphorous and dissolved metals.

SITE SPECIFIC DATA			
PROJECT NUMBER	602989		
PROJECT NAME	DANA POINT HARBOR REHABILITATION		
PROJECT LOCATION	DANA POINT, CA		
STRUCTURE ID	BMP-1		
TREATMENT REQUIRED			
VOLUME BASED (CF)	FLOW BASED (CFS)		
N/A	0.100		
TREATMENT HGL AVAILABLE (FT)	N/K		
PEAK BYPASS REQUIRED (CFS) - IF APPLICABLE	DVERT		
PIPE DATA	I.E.	MATERIAL	DIAMETER
INLET PIPE 1	15.88	HDPE	6"
OUTLET PIPE	13.71	HDPE	8"
	PRETREATMENT	BIOFILTRATION	DISCHARGE
RIM ELEVATION	18.21	18.21	18.21
SURFACE LOAD	H-20	N/A	H-20
FRAME & COVER	36" X 36"	OPEN PLANTER	N/A
WETLANDMEDIA VOLUME (CY)	2.24		
ORIFICE SIZE (DIA. INCHES)	ø1.48"		
NOTES: PRELIMINARY NOT FOR CONSTRUCTION. DVERT INV-OUT OF CATCH BASIN SET AT 16.16 TO BYPASS FLOWS AT 16.83. DVERT LENGTH = 6'.			

### INSTALLATION NOTES

- CONTRACTOR TO PROVIDE ALL LABOR, EQUIPMENT, MATERIALS AND INCIDENTALS REQUIRED TO OFFLOAD AND INSTALL THE SYSTEM AND APPURTENANCES IN ACCORDANCE WITH THIS DRAWING AND THE MANUFACTURERS' SPECIFICATIONS, UNLESS OTHERWISE STATED IN MANUFACTURER'S CONTRACT.
- UNIT MUST BE INSTALLED ON LEVEL BASE. MANUFACTURER RECOMMENDS A MINIMUM 6" LEVEL ROCK BASE UNLESS SPECIFIED BY THE PROJECT ENGINEER. CONTRACTOR IS RESPONSIBLE FOR VERIFYING PROJECT ENGINEER'S RECOMMENDED BASE SPECIFICATIONS.
- CONTRACTOR TO SUPPLY AND INSTALL ALL EXTERNAL CONNECTING PIPES. ALL PIPES MUST BE FLUSH WITH INSIDE SURFACE OF CONCRETE (PIPES CANNOT INTRUDE BEYOND FLUSH). INVERT OF OUTFLOW PIPE MUST BE FLUSH WITH DISCHARGE CHAMBER FLOOR. ALL PIPES SHALL BE SEALED WATERTIGHT PER MANUFACTURER'S STANDARD CONNECTION DETAIL.
- CONTRACTOR RESPONSIBLE FOR INSTALLATION OF ALL PIPES, RISERS, MANHOLES, AND HATCHES. CONTRACTOR TO GROUT ALL MANHOLES AND HATCHES TO MATCH FINISHED SURFACE UNLESS SPECIFIED OTHERWISE.
- VEGETATION SUPPLIED AND INSTALLED BY OTHERS. ALL UNITS WITH VEGETATION MUST HAVE DRIP OR SPRAY IRRIGATION SUPPLIED AND INSTALLED BY OTHERS.
- CONTRACTOR RESPONSIBLE FOR CONTACTING BIO CLEAN FOR ACTIVATION OF UNIT. MANUFACTURER'S WARRANTY IS VOID WITHOUT PROPER ACTIVATION BY A BIO CLEAN REPRESENTATIVE.

### GENERAL NOTES

- MANUFACTURER TO PROVIDE ALL MATERIALS UNLESS OTHERWISE NOTED.
- ALL DIMENSIONS, ELEVATIONS, SPECIFICATIONS AND CAPACITIES ARE SUBJECT TO CHANGE. FOR PROJECT SPECIFIC DRAWINGS DETAILING EXACT DIMENSIONS, WEIGHTS AND ACCESSORIES PLEASE CONTACT BIO CLEAN.

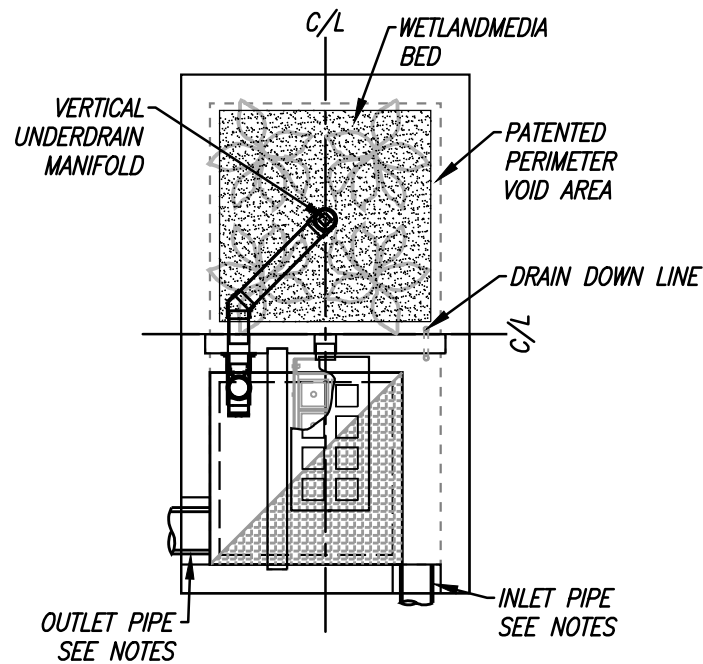

**PLAN VIEW**

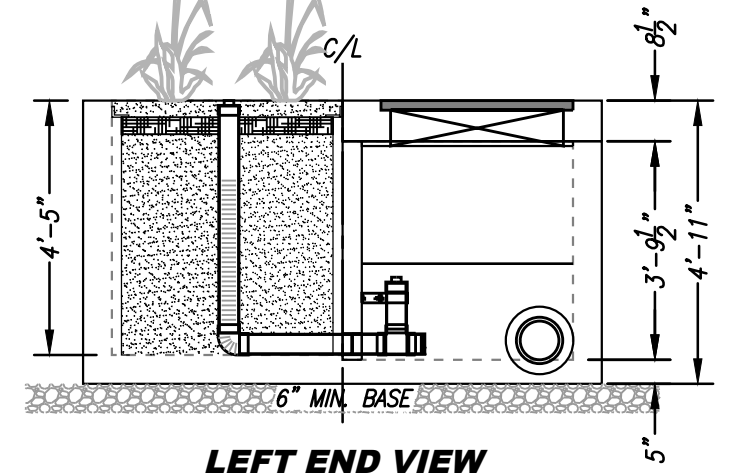

**LEFT END VIEW**

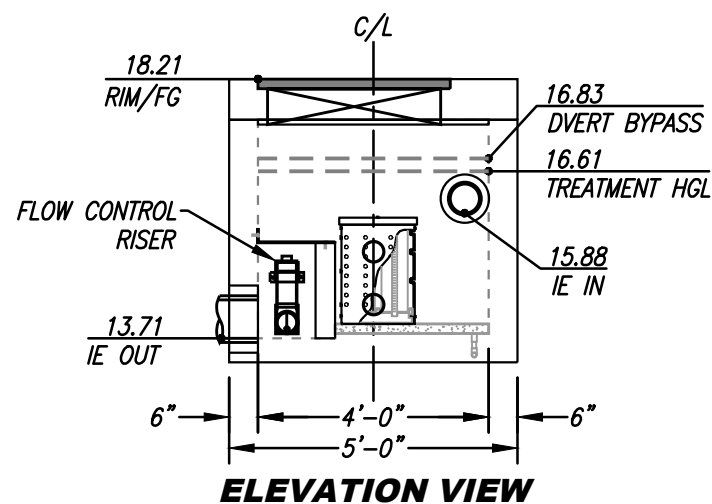

**ELEVATION VIEW**

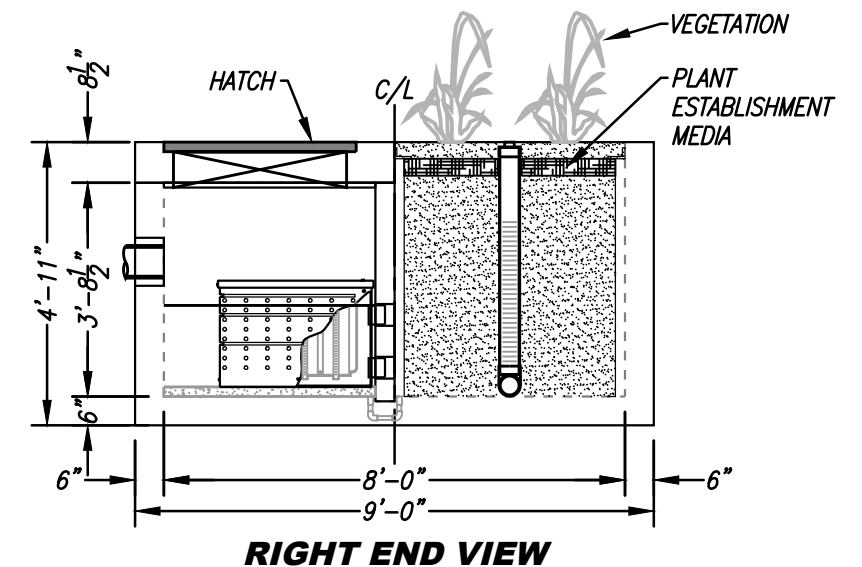

**RIGHT END VIEW**

TREATMENT FLOW (CFS)	0.100
MAXIMUM TREATMENT CAPACITY (CFS)	0.099
OPERATING HEAD (FT)	2.9
PRETREATMENT LOADING RATE (GPM/SF)	1.8
WETLAND MEDIA LOADING RATE (GPM/SF)	1.0

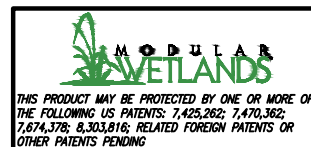

PROPRIETARY AND CONFIDENTIAL:  
THE INFORMATION CONTAINED IN THIS DOCUMENT IS THE SOLE PROPERTY OF FORTERRA AND ITS COMPANIES. THIS DOCUMENT, NOR ANY PART THEREOF, MAY BE USED, REPRODUCED OR MODIFIED IN ANY MANNER WITHOUT THE WRITTEN CONSENT OF FORTERRA.



**MWS-L-4-8-4'-5"-V**  
**STORMWATER BIOFILTRATION SYSTEM**  
**STANDARD DETAIL**

SITE SPECIFIC DATA			
PROJECT NUMBER	9931		
PROJECT NAME	DANA POINT HARBOR REVITALIZATION - COMMERCIAL CORE AREA		
PROJECT LOCATION	DANA POINT, CA		
STRUCTURE ID	BMP 2		
TREATMENT REQUIRED			
VOLUME BASED (CF)	FLOW BASED (CFS)		
N/A	0.202		
TREATMENT HGL AVAILABLE (FT)	N/K		
PEAK BYPASS REQUIRED (CFS) - IF APPLICABLE	DVERT		
PIPE DATA	I.E.	MATERIAL	DIAMETER
INLET PIPE 1	16.42	HDPE	8"
OUTLET PIPE	14.48	HDPE	8"
	PRETREATMENT	BIOFILTRATION	DISCHARGE
RIM ELEVATION	19.31	19.31	19.31
SURFACE LOAD	H-20	N/A	H-20
FRAME & COVER	ø30"	OPEN PLANTER	ø24"
WETLAND MEDIA VOLUME (CY)	7.49		
ORIFICE SIZE (DIA. INCHES)	ø2.11"		
NOTES: PRELIMINARY NOT FOR CONSTRUCTION. DVERT INV-OUT OF CATCH BASIN SET AT 16.75 TO BYPASS FLOWS AT 17.42. DVERT LENGTH = 4'.			

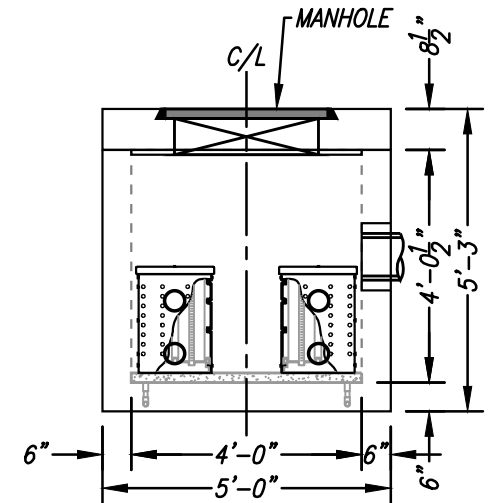
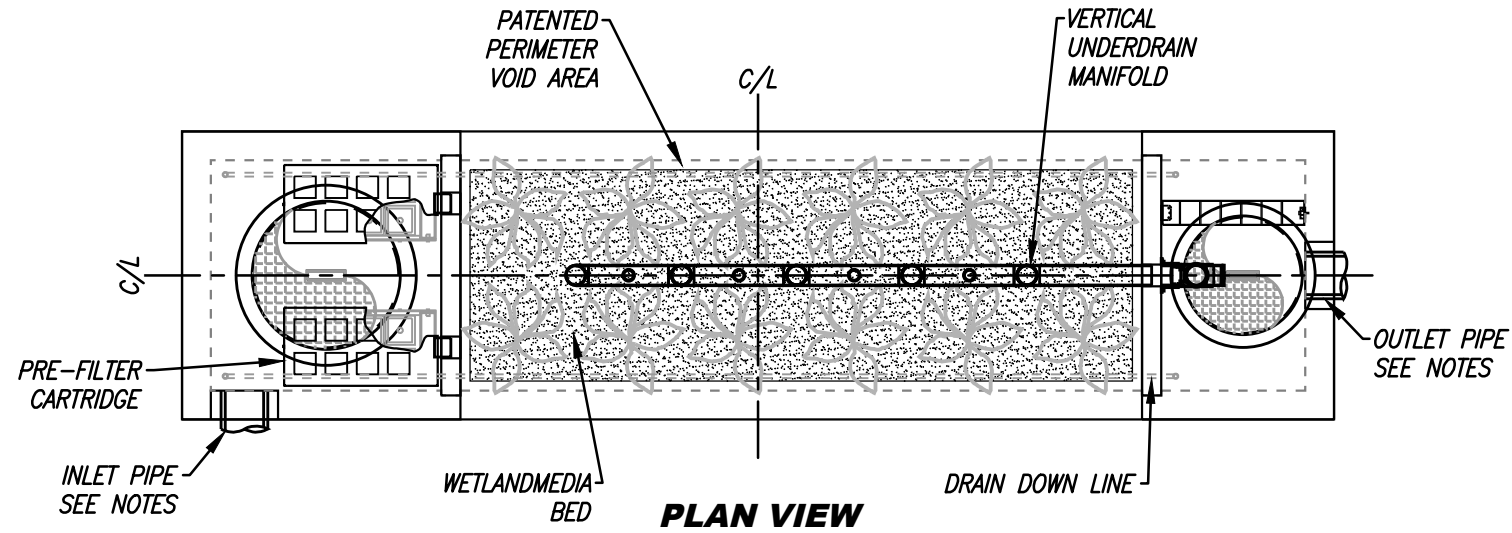

**LEFT END VIEW**

**INSTALLATION NOTES**

1. CONTRACTOR TO PROVIDE ALL LABOR, EQUIPMENT, MATERIALS AND INCIDENTALS REQUIRED TO OFFLOAD AND INSTALL THE SYSTEM AND APPURTENANCES IN ACCORDANCE WITH THIS DRAWING AND THE MANUFACTURERS' SPECIFICATIONS, UNLESS OTHERWISE STATED IN MANUFACTURER'S CONTRACT.
2. UNIT MUST BE INSTALLED ON LEVEL BASE. MANUFACTURER RECOMMENDS A MINIMUM 6" LEVEL ROCK BASE UNLESS SPECIFIED BY THE PROJECT ENGINEER. CONTRACTOR IS RESPONSIBLE FOR VERIFYING PROJECT ENGINEER'S RECOMMENDED BASE SPECIFICATIONS.
4. CONTRACTOR TO SUPPLY AND INSTALL ALL EXTERNAL CONNECTING PIPES. ALL PIPES MUST BE FLUSH WITH INSIDE SURFACE OF CONCRETE (PIPES CANNOT INTRUDE BEYOND FLUSH). INVERT OF OUTFLOW PIPE MUST BE FLUSH WITH DISCHARGE CHAMBER FLOOR. ALL PIPES SHALL BE SEALED WATERTIGHT PER MANUFACTURER'S STANDARD CONNECTION DETAIL.
5. CONTRACTOR RESPONSIBLE FOR INSTALLATION OF ALL PIPES, RISERS, MANHOLES, AND HATCHES. CONTRACTOR TO GROUT ALL MANHOLES AND HATCHES TO MATCH FINISHED SURFACE UNLESS SPECIFIED OTHERWISE.
6. VEGETATION SUPPLIED AND INSTALLED BY OTHERS. ALL UNITS WITH VEGETATION MUST HAVE DRIP OR SPRAY IRRIGATION SUPPLIED AND INSTALLED BY OTHERS.
7. CONTRACTOR RESPONSIBLE FOR CONTACTING BIO CLEAN FOR ACTIVATION OF UNIT. MANUFACTURER'S WARRANTY IS VOID WITHOUT PROPER ACTIVATION BY A BIO CLEAN REPRESENTATIVE.

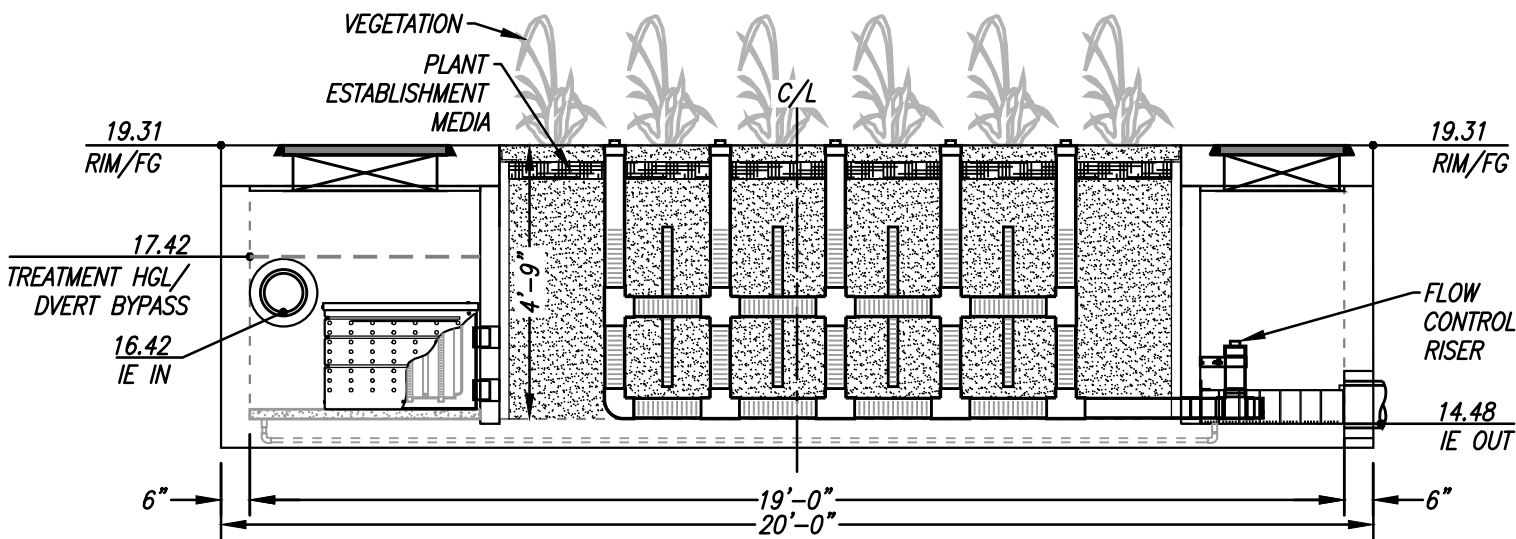

**ELEVATION VIEW**

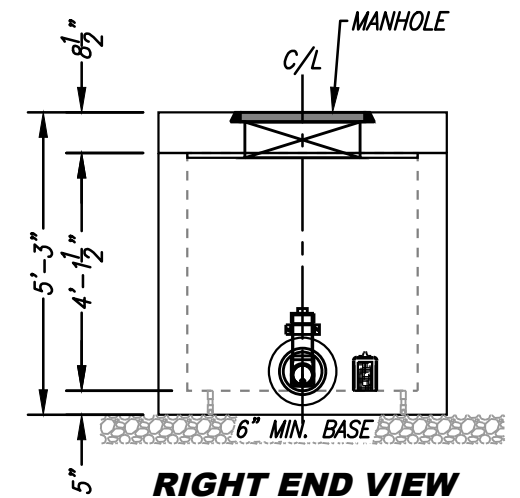

**RIGHT END VIEW**

**GENERAL NOTES**

1. MANUFACTURER TO PROVIDE ALL MATERIALS UNLESS OTHERWISE NOTED.
2. ALL DIMENSIONS, ELEVATIONS, SPECIFICATIONS AND CAPACITIES ARE SUBJECT TO CHANGE. FOR PROJECT SPECIFIC DRAWINGS DETAILING EXACT DIMENSIONS, WEIGHTS AND ACCESSORIES PLEASE CONTACT BIO CLEAN.

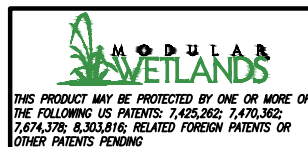

PROPRIETARY AND CONFIDENTIAL:  
THE INFORMATION CONTAINED IN THIS DOCUMENT IS THE SOLE PROPERTY OF FORTERRA AND ITS COMPANIES. THIS DOCUMENT, NOR ANY PART THEREOF, MAY BE USED, REPRODUCED OR MODIFIED IN ANY MANNER WITHOUT THE WRITTEN CONSENT OF FORTERRA.



TREATMENT FLOW (CFS)	0.202
MAXIMUM TREATMENT CAPACITY (CFS)	0.202
OPERATING HEAD (FT)	2.9
PRETREATMENT LOADING RATE (GPM/SF)	1.8
WETLAND MEDIA LOADING RATE (GPM/SF)	1.0

**MWS-L-4-19-4'-9"-V**  
**STORMWATER BIOFILTRATION SYSTEM**  
**STANDARD DETAIL**



SITE SPECIFIC DATA			
PROJECT NUMBER	602989		
PROJECT NAME	DANA POINT HARBOR REVITALIZATION - COMMERCIAL CORE AREA		
PROJECT LOCATION	DANA POINT, CA		
STRUCTURE ID	BMP 4		
TREATMENT REQUIRED			
VOLUME BASED (CF)	FLOW BASED (CFS)		
N/A	0.457		
TREATMENT HGL AVAILABLE (FT)	N/K		
PEAK BYPASS REQUIRED (CFS) - IF APPLICABLE	DVERT		
PIPE DATA	I.E.	MATERIAL	DIAMETER
INLET PIPE 1	12.95	HDPE	8"
INLET PIPE 2	12.95	HDPE	8"
OUTLET PIPE	11.08	HDPE	8"
	PRETREATMENT	BIOFILTRATION	DISCHARGE
RIM ELEVATION	16.50	16.50	16.50
SURFACE LOAD	PEDESTRIAN	N/A	PEDESTRIAN
FRAME & COVER	2EA $\phi$ 30"	OPEN PLANTER	$\phi$ 30"
WETLAND MEDIA VOLUME (CY)	10.82		
ORIFICE SIZE (DIA. INCHES)	$\phi$ 3.06"		
NOTES: PRELIMINARY NOT FOR CONSTRUCTION. DVERT INV-OUT OF CATCH BASINS MUST BE SET AT 13.89 TO BYPASS FLOWS AT 14.55. DVERT LENGTH = 8' (TWO CATCH BASINS).			

**INSTALLATION NOTES**

1. CONTRACTOR TO PROVIDE ALL LABOR, EQUIPMENT, MATERIALS AND INCIDENTALS REQUIRED TO OFFLOAD AND INSTALL THE SYSTEM AND APPURTENANCES IN ACCORDANCE WITH THIS DRAWING AND THE MANUFACTURER'S SPECIFICATIONS, UNLESS OTHERWISE STATED IN MANUFACTURER'S CONTRACT.
2. UNIT MUST BE INSTALLED ON LEVEL BASE. MANUFACTURER RECOMMENDS A MINIMUM 6" LEVEL ROCK BASE UNLESS SPECIFIED BY THE PROJECT ENGINEER. CONTRACTOR IS RESPONSIBLE FOR VERIFYING PROJECT ENGINEER'S RECOMMENDED BASE SPECIFICATIONS.
4. CONTRACTOR TO SUPPLY AND INSTALL ALL EXTERNAL CONNECTING PIPES. ALL PIPES MUST BE FLUSH WITH INSIDE SURFACE OF CONCRETE (PIPES CANNOT INTRUDE BEYOND FLUSH). INVERT OF OUTFLOW PIPE MUST BE FLUSH WITH DISCHARGE CHAMBER FLOOR. ALL PIPES SHALL BE SEALED WATERTIGHT PER MANUFACTURER'S STANDARD CONNECTION DETAIL.
5. CONTRACTOR RESPONSIBLE FOR INSTALLATION OF ALL PIPES, RISERS, MANHOLES, AND HATCHES. CONTRACTOR TO GROUT ALL MANHOLES AND HATCHES TO MATCH FINISHED SURFACE UNLESS SPECIFIED OTHERWISE.
6. VEGETATION SUPPLIED AND INSTALLED BY OTHERS. ALL UNITS WITH VEGETATION MUST HAVE DRIP OR SPRAY IRRIGATION SUPPLIED AND INSTALLED BY OTHERS.
7. CONTRACTOR RESPONSIBLE FOR CONTACTING BIO CLEAN FOR ACTIVATION OF UNIT. MANUFACTURER'S WARRANTY IS VOID WITHOUT PROPER ACTIVATION BY A BIO CLEAN REPRESENTATIVE.

**GENERAL NOTES**

1. MANUFACTURER TO PROVIDE ALL MATERIALS UNLESS OTHERWISE NOTED.
2. ALL DIMENSIONS, ELEVATIONS, SPECIFICATIONS AND CAPACITIES ARE SUBJECT TO CHANGE. FOR PROJECT SPECIFIC DRAWINGS DETAILING EXACT DIMENSIONS, WEIGHTS AND ACCESSORIES PLEASE CONTACT BIO CLEAN.

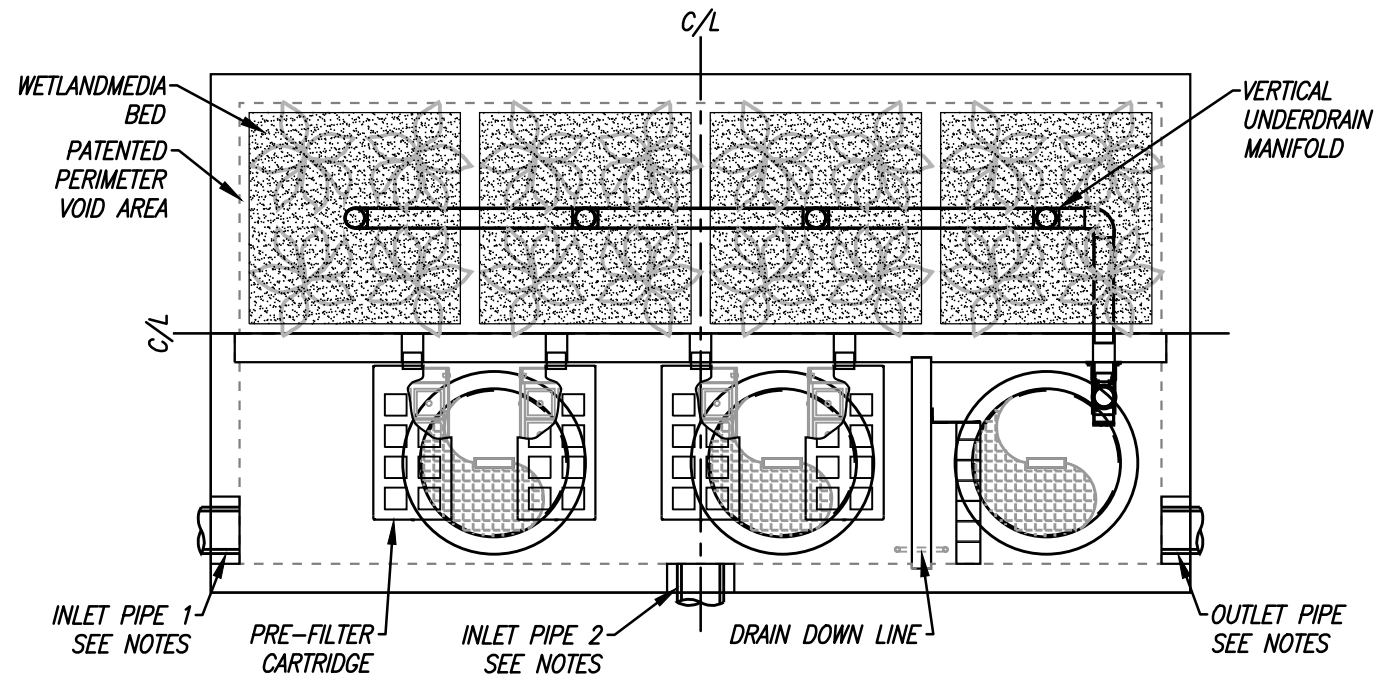

**PLAN VIEW**

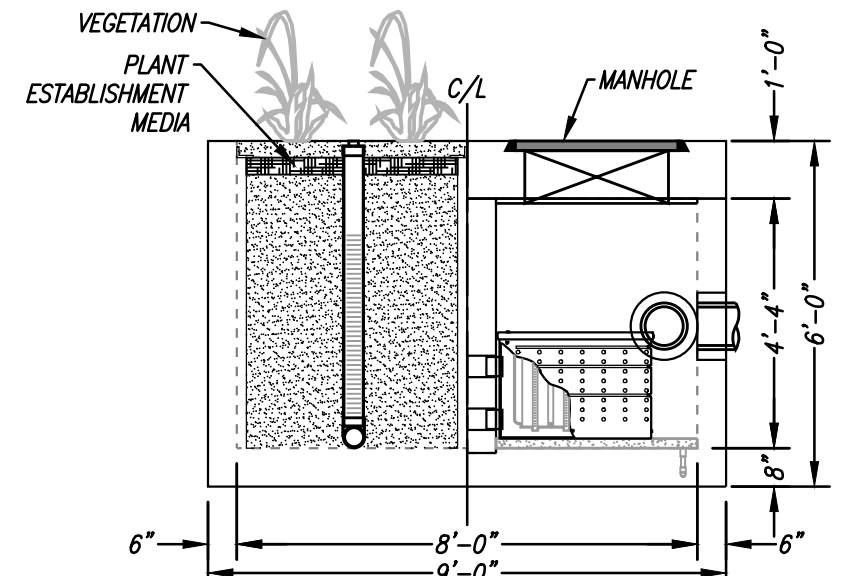

**LEFT END VIEW**

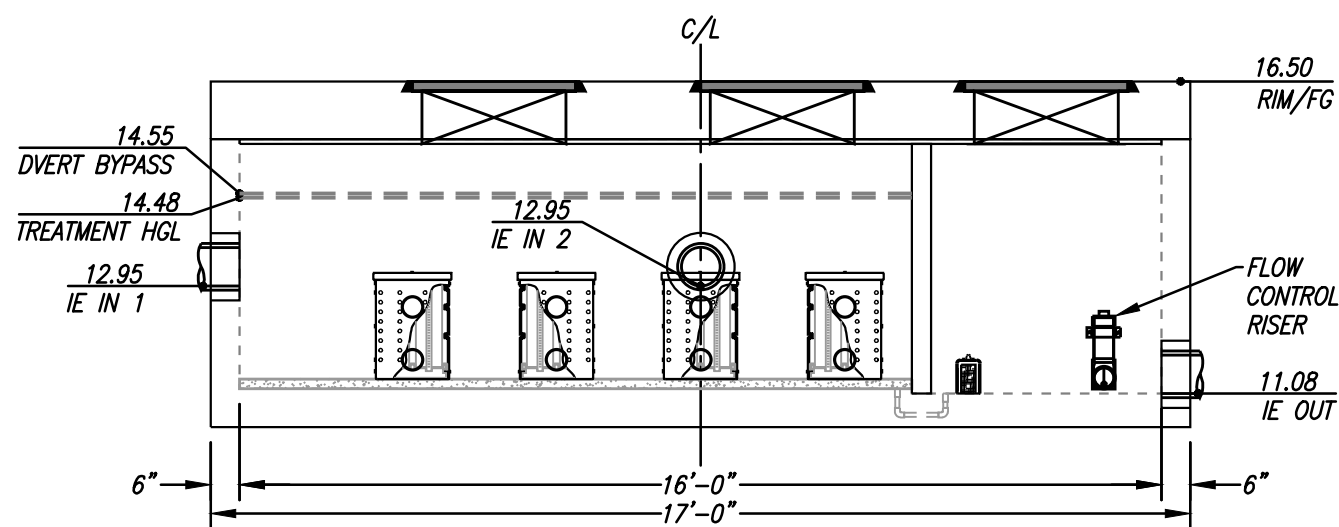

**ELEVATION VIEW**

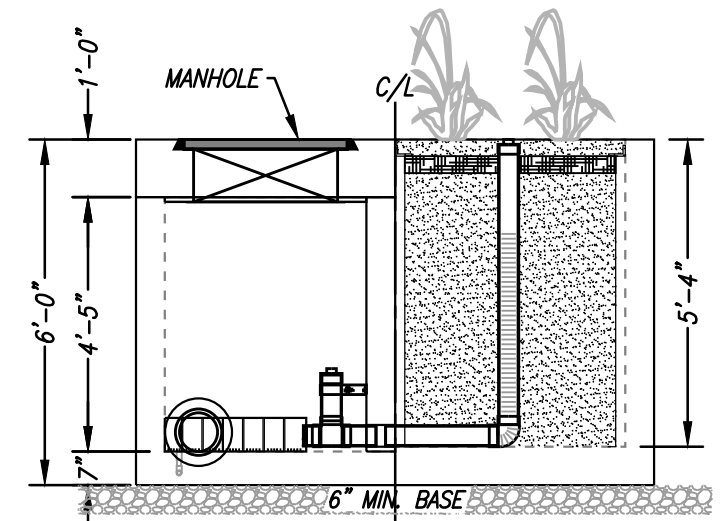

**RIGHT END VIEW**

TREATMENT FLOW (CFS)	0.457
MAXIMUM TREATMENT CAPACITY (CFS)	0.462
OPERATING HEAD (FT)	3.4
PRETREATMENT LOADING RATE (GPM/SF)	2.0
WETLAND MEDIA LOADING RATE (GPM/SF)	1.0

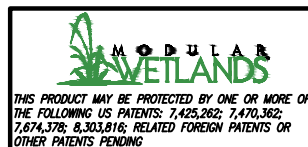

PROPRIETARY AND CONFIDENTIAL:  
 THE INFORMATION CONTAINED IN THIS DOCUMENT IS THE SOLE PROPERTY OF FORTERRA AND ITS COMPANIES. THIS DOCUMENT, NOR ANY PART THEREOF, MAY BE USED, REPRODUCED OR MODIFIED IN ANY MANNER WITHOUT THE WRITTEN CONSENT OF FORTERRA.



**MWS-L-8-16-5'-4"-V**  
**STORMWATER BIOFILTRATION SYSTEM**  
**STANDARD DETAIL**

SITE SPECIFIC DATA			
PROJECT NUMBER	602989		
PROJECT NAME	DANA POINT HARBOR REVITALIZATION - COMMERCIAL CORE AREA		
PROJECT LOCATION	DANA POINT, CA		
STRUCTURE ID	BMP 5		
TREATMENT REQUIRED			
VOLUME BASED (CF)	FLOW BASED (CFS)		
N/A	0.069		
TREATMENT HGL AVAILABLE (FT)	N/K		
PEAK BYPASS REQUIRED (CFS) - IF APPLICABLE	FLOW BY		
PIPE DATA	I.E.	MATERIAL	DIAMETER
INLET PIPE 1	N/A	N/A	N/A
OUTLET PIPE	10.81	HDPE	10"
	PRETREATMENT	BIOFILTRATION	DISCHARGE
RIM ELEVATION	14.89	14.89	14.89
SURFACE LOAD	H-20	N/A	H-20
FRAME & COVER	24" X 42"	OPEN PLANTER	N/A
WETLAND MEDIA VOLUME (CY)	1.48		
ORIFICE SIZE (DIA. INCHES)	Ø1.20"		
NOTES: PRELIMINARY NOT FOR CONSTRUCTION.			

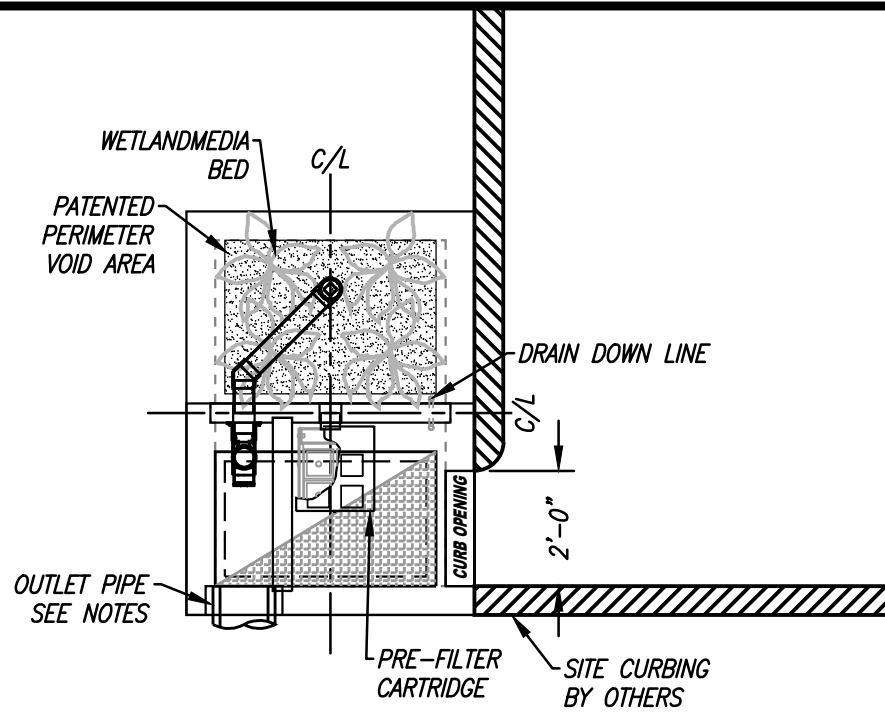

**PLAN VIEW**

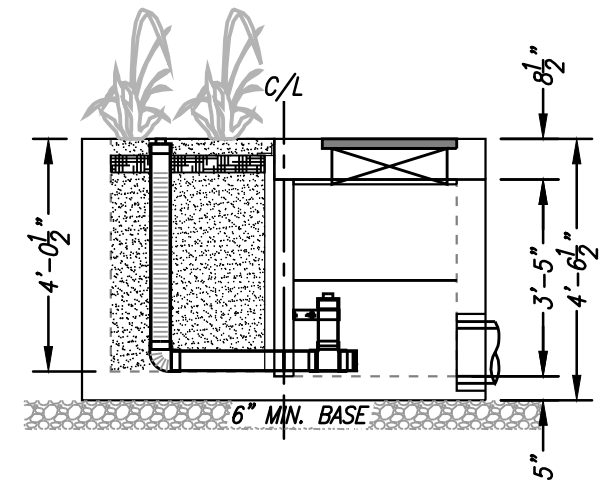

**LEFT END VIEW**

**INSTALLATION NOTES**

1. CONTRACTOR TO PROVIDE ALL LABOR, EQUIPMENT, MATERIALS AND INCIDENTALS REQUIRED TO OFFLOAD AND INSTALL THE SYSTEM AND APPURTENANCES IN ACCORDANCE WITH THIS DRAWING AND THE MANUFACTURERS' SPECIFICATIONS, UNLESS OTHERWISE STATED IN MANUFACTURER'S CONTRACT.
2. UNIT MUST BE INSTALLED ON LEVEL BASE. MANUFACTURER RECOMMENDS A MINIMUM 6" LEVEL ROCK BASE UNLESS SPECIFIED BY THE PROJECT ENGINEER. CONTRACTOR IS RESPONSIBLE FOR VERIFYING PROJECT ENGINEER'S RECOMMENDED BASE SPECIFICATIONS.
4. CONTRACTOR TO SUPPLY AND INSTALL ALL EXTERNAL CONNECTING PIPES. ALL PIPES MUST BE FLUSH WITH INSIDE SURFACE OF CONCRETE (PIPES CANNOT INTRUDE BEYOND FLUSH). INVERT OF OUTFLOW PIPE MUST BE FLUSH WITH DISCHARGE CHAMBER FLOOR. ALL PIPES SHALL BE SEALED WATERTIGHT PER MANUFACTURER'S STANDARD CONNECTION DETAIL.
5. CONTRACTOR RESPONSIBLE FOR INSTALLATION OF ALL PIPES, RISERS, MANHOLES, AND HATCHES. CONTRACTOR TO GROUT ALL MANHOLES AND HATCHES TO MATCH FINISHED SURFACE UNLESS SPECIFIED OTHERWISE.
6. VEGETATION SUPPLIED AND INSTALLED BY OTHERS. ALL UNITS WITH VEGETATION MUST HAVE DRIP OR SPRAY IRRIGATION SUPPLIED AND INSTALLED BY OTHERS.
7. CONTRACTOR RESPONSIBLE FOR CONTACTING BIO CLEAN FOR ACTIVATION OF UNIT. MANUFACTURER'S WARRANTY IS VOID WITHOUT PROPER ACTIVATION BY A BIO CLEAN REPRESENTATIVE.

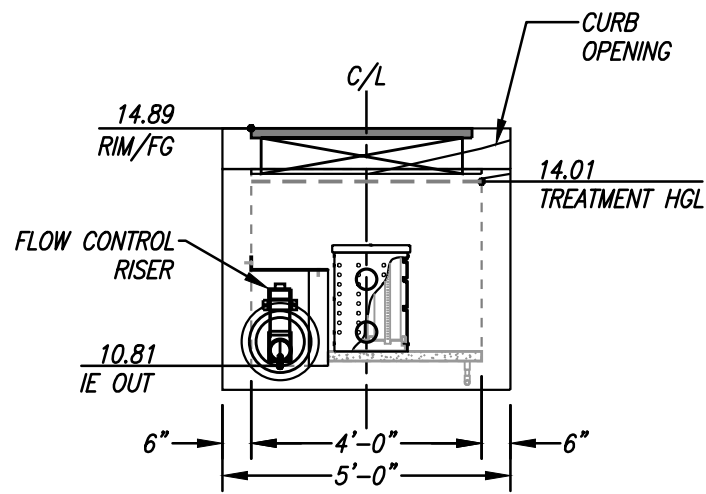

**ELEVATION VIEW**

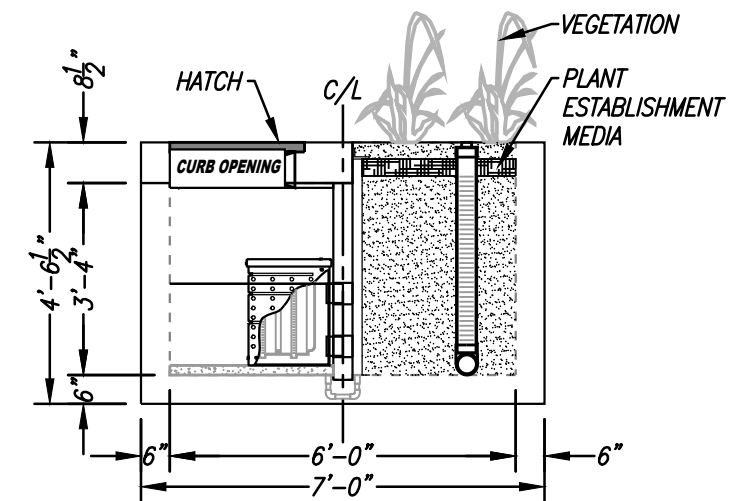

**RIGHT END VIEW**

TREATMENT FLOW (CFS)	0.069
MAXIMUM TREATMENT CAPACITY (CFS)	0.069
OPERATING HEAD (FT)	3.2
PRETREATMENT LOADING RATE (GPM/SF)	2.4
WETLAND MEDIA LOADING RATE (GPM/SF)	1.0

**GENERAL NOTES**

1. MANUFACTURER TO PROVIDE ALL MATERIALS UNLESS OTHERWISE NOTED.
2. ALL DIMENSIONS, ELEVATIONS, SPECIFICATIONS AND CAPACITIES ARE SUBJECT TO CHANGE. FOR PROJECT SPECIFIC DRAWINGS DETAILING EXACT DIMENSIONS, WEIGHTS AND ACCESSORIES PLEASE CONTACT BIO CLEAN.

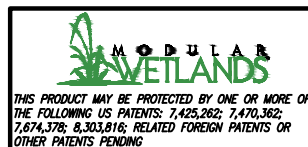

PROPRIETARY AND CONFIDENTIAL:  
THE INFORMATION CONTAINED IN THIS DOCUMENT IS THE SOLE PROPERTY OF FORTERRA AND ITS COMPANIES. THIS DOCUMENT, NOR ANY PART THEREOF, MAY BE USED, REPRODUCED OR MODIFIED IN ANY MANNER WITH OUT THE WRITTEN CONSENT OF FORTERRA.



**MWS-L-4-6-4'-0\"/>**

SITE SPECIFIC DATA			
PROJECT NUMBER	602989		
PROJECT NAME	DANA POINT HARBOR REVITALIZATION - COMMERCIAL CORE AREA		
PROJECT LOCATION	DANA POINT, CA		
STRUCTURE ID	BMP 6		
TREATMENT REQUIRED			
VOLUME BASED (CF)	FLOW BASED (CFS)		
N/A	0.239		
TREATMENT HGL AVAILABLE (FT)	N/K		
PEAK BYPASS REQUIRED (CFS) - IF APPLICABLE	DVERT		
PIPE DATA	I.E.	MATERIAL	DIAMETER
INLET PIPE 1	13.08	HDPE	8"
OUTLET PIPE	10.25	HDPE	8"
	PRETREATMENT	BIOFILTRATION	DISCHARGE
RIM ELEVATION	16.00	16.00	16.00
SURFACE LOAD	H-20	N/A	H-20
FRAME & COVER	ø30"	OPEN PLANTER	ø24"
WETLAND MEDIA VOLUME (CY)	7.38		
ORIFICE SIZE (DIA. INCHES)	ø2.13"		
NOTES: PRELIMINARY NOT FOR CONSTRUCTION. DVERT INV-OUT OF CATCH BASINS MUST BE SET AT 13.54 SO PEAK FLOWS BYPASS AT 14.21. DVERT LENGTH = 8' (TWO CATCH BASINS).			

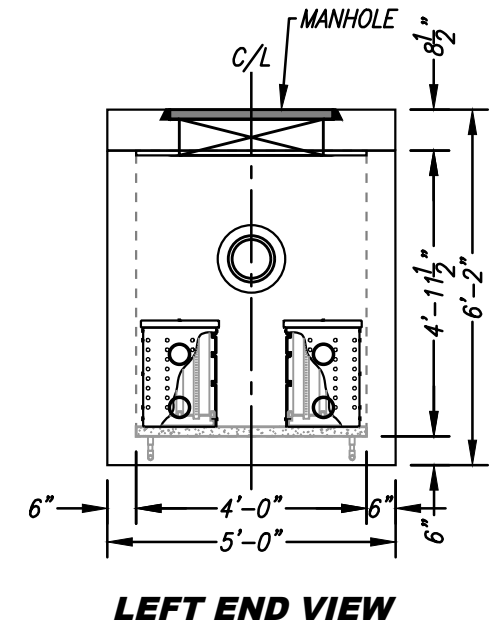
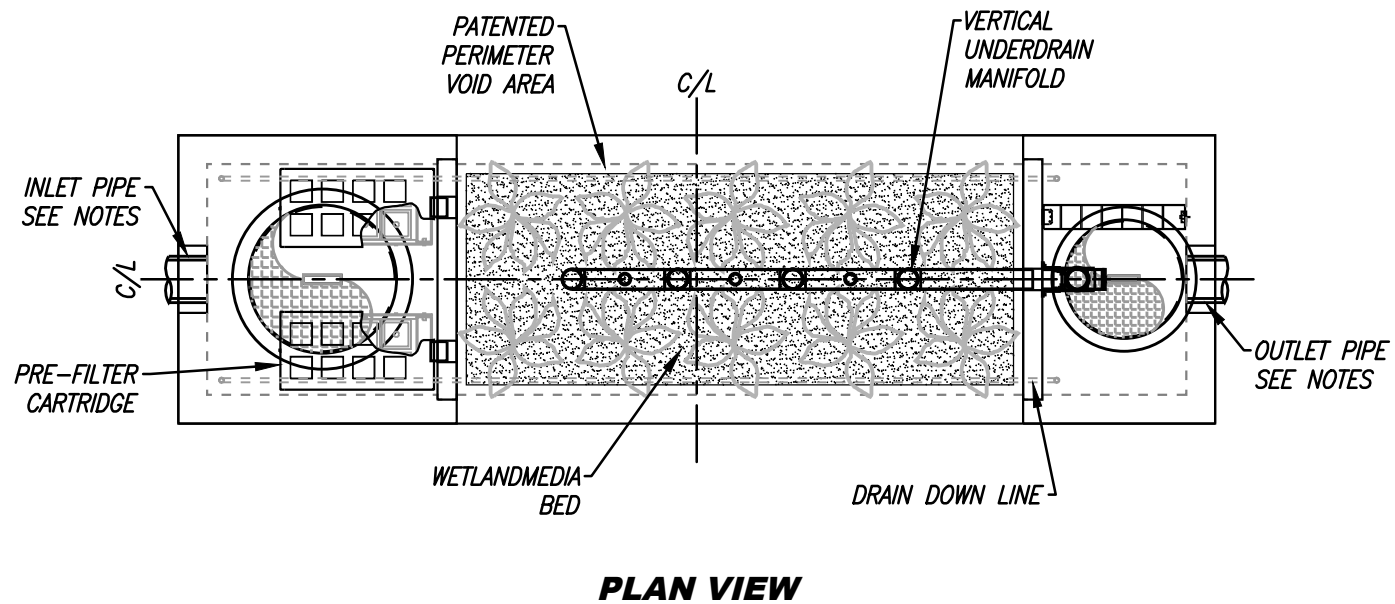

### INSTALLATION NOTES

1. CONTRACTOR TO PROVIDE ALL LABOR, EQUIPMENT, MATERIALS AND INCIDENTALS REQUIRED TO OFFLOAD AND INSTALL THE SYSTEM AND APPURTENANCES IN ACCORDANCE WITH THIS DRAWING AND THE MANUFACTURER'S SPECIFICATIONS, UNLESS OTHERWISE STATED IN MANUFACTURER'S CONTRACT.
2. UNIT MUST BE INSTALLED ON LEVEL BASE. MANUFACTURER RECOMMENDS A MINIMUM 6" LEVEL ROCK BASE UNLESS SPECIFIED BY THE PROJECT ENGINEER. CONTRACTOR IS RESPONSIBLE FOR VERIFYING PROJECT ENGINEER'S RECOMMENDED BASE SPECIFICATIONS.
4. CONTRACTOR TO SUPPLY AND INSTALL ALL EXTERNAL CONNECTING PIPES. ALL PIPES MUST BE FLUSH WITH INSIDE SURFACE OF CONCRETE (PIPES CANNOT INTRUDE BEYOND FLUSH). INVERT OF OUTFLOW PIPE MUST BE FLUSH WITH DISCHARGE CHAMBER FLOOR. ALL PIPES SHALL BE SEALED WATERTIGHT PER MANUFACTURER'S STANDARD CONNECTION DETAIL.
5. CONTRACTOR RESPONSIBLE FOR INSTALLATION OF ALL PIPES, RISERS, MANHOLES, AND HATCHES. CONTRACTOR TO GROUT ALL MANHOLES AND HATCHES TO MATCH FINISHED SURFACE UNLESS SPECIFIED OTHERWISE.
6. VEGETATION SUPPLIED AND INSTALLED BY OTHERS. ALL UNITS WITH VEGETATION MUST HAVE DRIP OR SPRAY IRRIGATION SUPPLIED AND INSTALLED BY OTHERS.
7. CONTRACTOR RESPONSIBLE FOR CONTACTING BIO CLEAN FOR ACTIVATION OF UNIT. MANUFACTURER'S WARRANTY IS VOID WITHOUT PROPER ACTIVATION BY A BIO CLEAN REPRESENTATIVE.

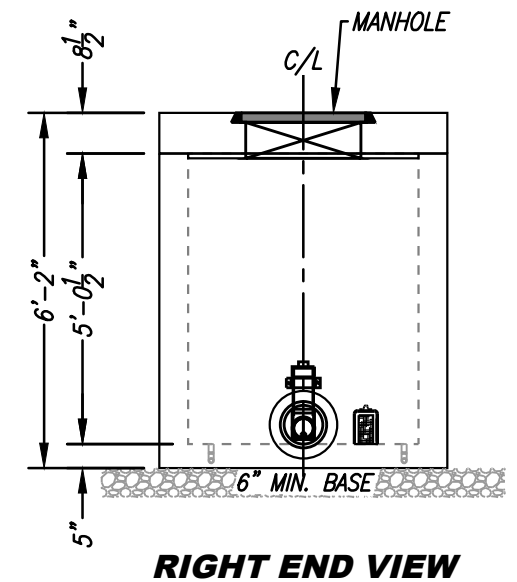
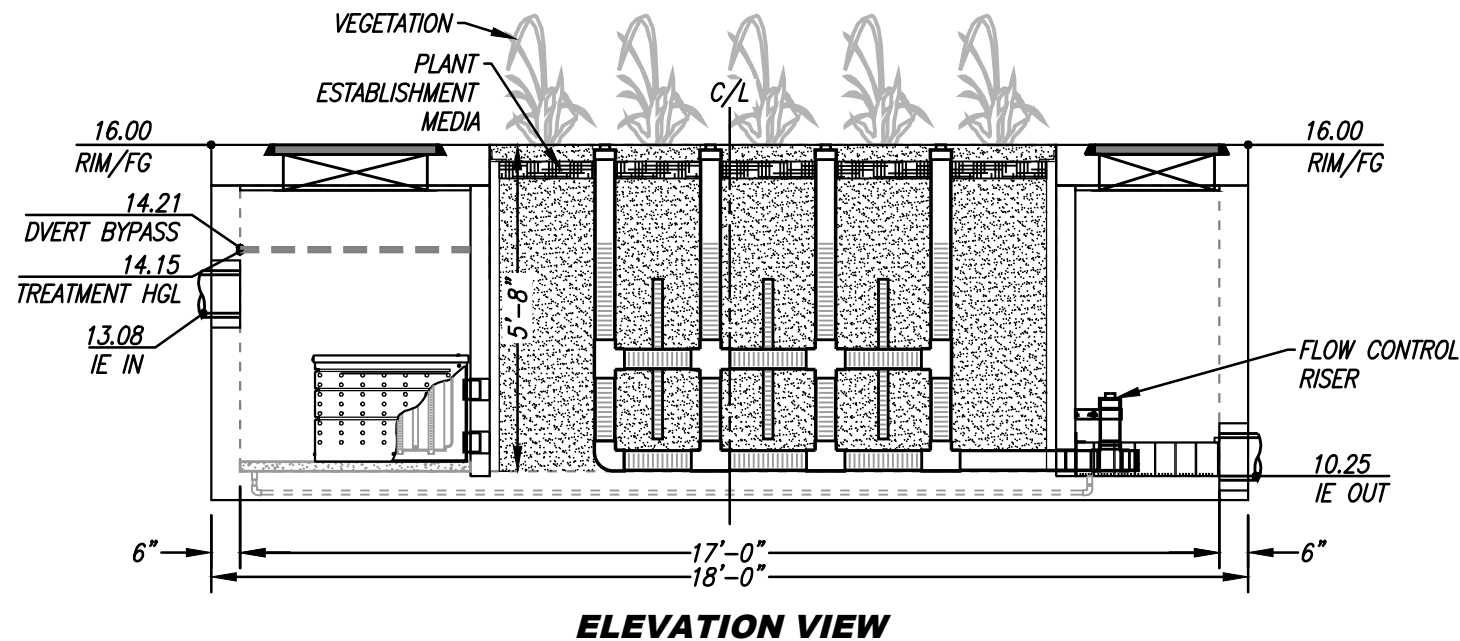

### GENERAL NOTES

1. MANUFACTURER TO PROVIDE ALL MATERIALS UNLESS OTHERWISE NOTED.
2. ALL DIMENSIONS, ELEVATIONS, SPECIFICATIONS AND CAPACITIES ARE SUBJECT TO CHANGE. FOR PROJECT SPECIFIC DRAWINGS DETAILING EXACT DIMENSIONS, WEIGHTS AND ACCESSORIES PLEASE CONTACT BIO CLEAN.

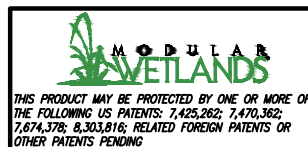

PROPRIETARY AND CONFIDENTIAL:  
THE INFORMATION CONTAINED IN THIS DOCUMENT IS THE SOLE PROPERTY OF FORTERRA AND ITS COMPANIES. THIS DOCUMENT, IN OR ANY PART THEREOF, MAY BE USED, REPRODUCED OR MODIFIED IN ANY MANNER WITHOUT THE WRITTEN CONSENT OF FORTERRA.



TREATMENT FLOW (CFS)	0.239
MAXIMUM TREATMENT CAPACITY (CFS)	0.239
OPERATING HEAD (FT)	3.9
PRETREATMENT LOADING RATE (GPM/SF)	2.1
WETLAND MEDIA LOADING RATE (GPM/SF)	1.0

**MWS-L-4-17-5'-8"-V-HC**  
**STORMWATER BIOFILTRATION SYSTEM**  
**STANDARD DETAIL**









SITE SPECIFIC DATA			
PROJECT NUMBER	9931		
PROJECT NAME	DANA POINT HARBOR REVITALIZATION - COMMERCIAL CORE AREA		
PROJECT LOCATION	DANA POINT, CA		
STRUCTURE ID	BMP 11		
TREATMENT REQUIRED			
VOLUME BASED (CF)	FLOW BASED (CFS)		
N/A	0.177		
TREATMENT HGL AVAILABLE (FT)	N/K		
PEAK BYPASS REQUIRED (CFS) - IF APPLICABLE	DVERT		
PIPE DATA	I.E.	MATERIAL	DIAMETER
BYPASS PIPE	9.05	HDPE	10"
OUTLET PIPE	7.64	HDPE	10"
	PRETREATMENT	BIOFILTRATION	DISCHARGE
RIM ELEVATION	11.97	11.97	11.97
SURFACE LOAD	H-20	N/A	H-20
FRAME & COVER	ø30"	OPEN PLANTER	ø24"
WETLAND MEDIA VOLUME (CY)	5.20		
ORIFICE SIZE (DIA. INCHES)	ø1.97"		
NOTES: PRELIMINARY NOT FOR CONSTRUCTION. DVERT INV-OUT OF CATCH BASIN MUST BE SET AT 9.93 TO BYPASS PEAK FLOWS AT 10.59. DVERT LENGTH = 6'.			

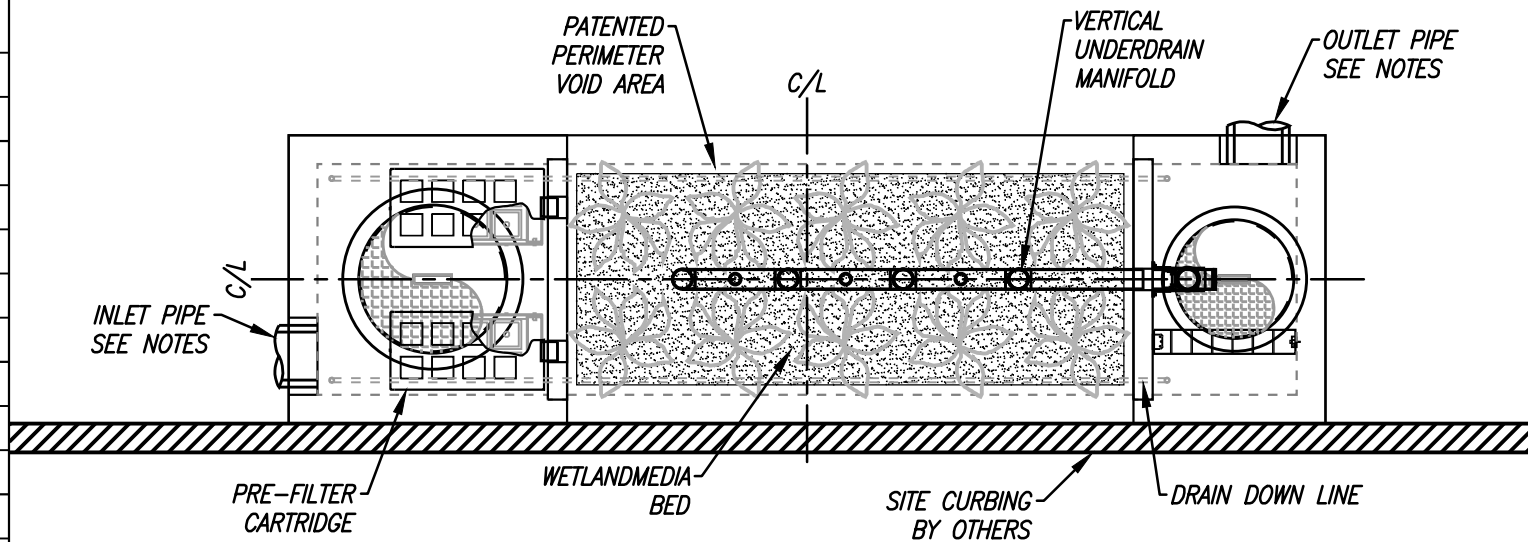

**PLAN VIEW**

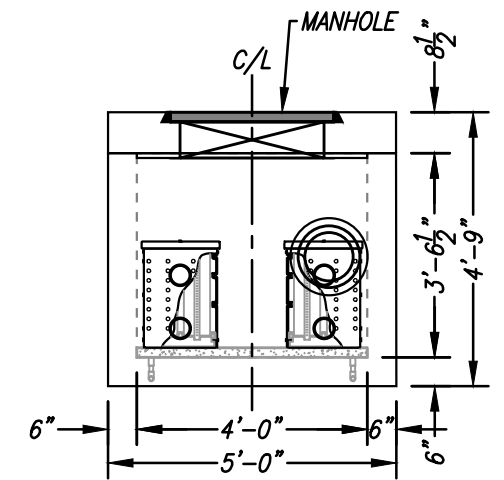

**LEFT END VIEW**

**INSTALLATION NOTES**

1. CONTRACTOR TO PROVIDE ALL LABOR, EQUIPMENT, MATERIALS AND INCIDENTALS REQUIRED TO OFFLOAD AND INSTALL THE SYSTEM AND APPURTENANCES IN ACCORDANCE WITH THIS DRAWING AND THE MANUFACTURERS' SPECIFICATIONS, UNLESS OTHERWISE STATED IN MANUFACTURER'S CONTRACT.
2. UNIT MUST BE INSTALLED ON LEVEL BASE. MANUFACTURER RECOMMENDS A MINIMUM 6" LEVEL ROCK BASE UNLESS SPECIFIED BY THE PROJECT ENGINEER. CONTRACTOR IS RESPONSIBLE FOR VERIFYING PROJECT ENGINEER'S RECOMMENDED BASE SPECIFICATIONS.
4. CONTRACTOR TO SUPPLY AND INSTALL ALL EXTERNAL CONNECTING PIPES. ALL PIPES MUST BE FLUSH WITH INSIDE SURFACE OF CONCRETE (PIPES CANNOT INTRUDE BEYOND FLUSH). INVERT OF OUTFLOW PIPE MUST BE FLUSH WITH DISCHARGE CHAMBER FLOOR. ALL PIPES SHALL BE SEALED WATERTIGHT PER MANUFACTURER'S STANDARD CONNECTION DETAIL.
5. CONTRACTOR RESPONSIBLE FOR INSTALLATION OF ALL PIPES, RISERS, MANHOLES, AND HATCHES. CONTRACTOR TO GROUT ALL MANHOLES AND HATCHES TO MATCH FINISHED SURFACE UNLESS SPECIFIED OTHERWISE.
6. VEGETATION SUPPLIED AND INSTALLED BY OTHERS. ALL UNITS WITH VEGETATION MUST HAVE DRIP OR SPRAY IRRIGATION SUPPLIED AND INSTALLED BY OTHERS.
7. CONTRACTOR RESPONSIBLE FOR CONTACTING BIO CLEAN FOR ACTIVATION OF UNIT. MANUFACTURER'S WARRANTY IS VOID WITHOUT PROPER ACTIVATION BY A BIO CLEAN REPRESENTATIVE.

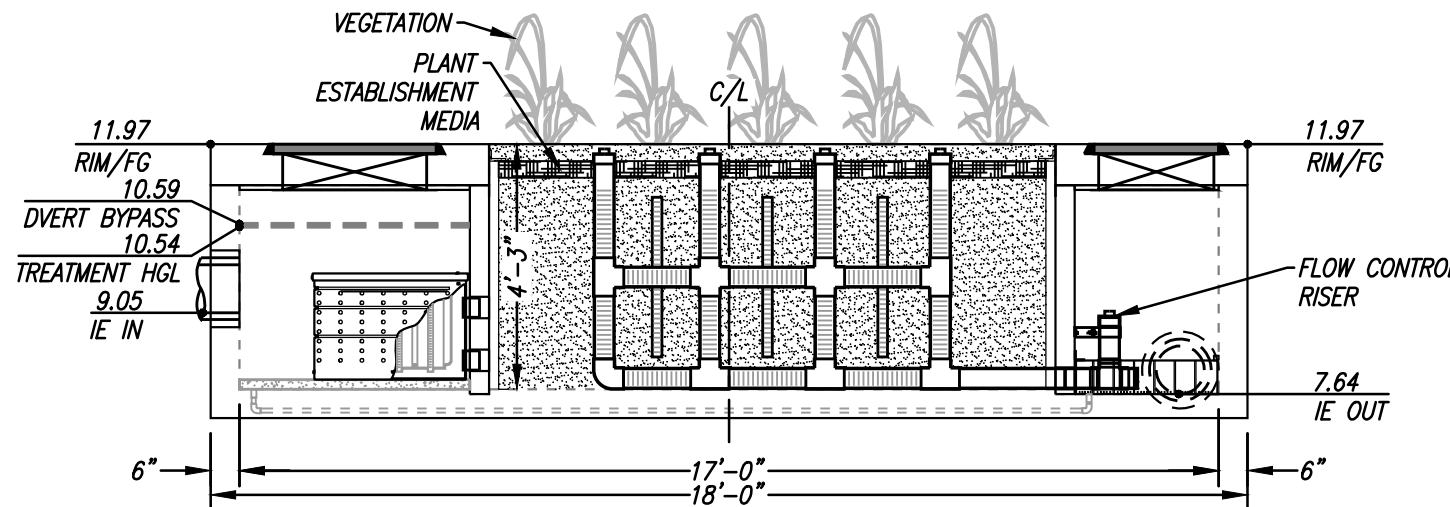

**ELEVATION VIEW**

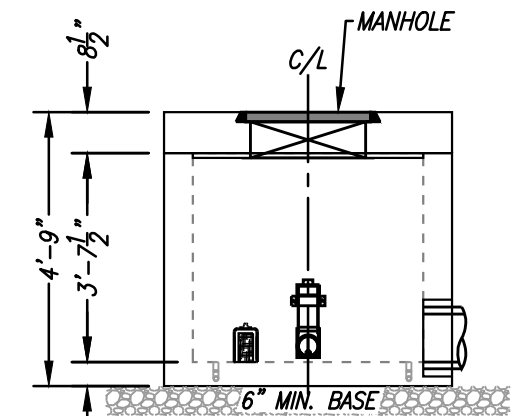

**RIGHT END VIEW**

**GENERAL NOTES**

1. MANUFACTURER TO PROVIDE ALL MATERIALS UNLESS OTHERWISE NOTED.
2. ALL DIMENSIONS, ELEVATIONS, SPECIFICATIONS AND CAPACITIES ARE SUBJECT TO CHANGE. FOR PROJECT SPECIFIC DRAWINGS DETAILING EXACT DIMENSIONS, WEIGHTS AND ACCESSORIES PLEASE CONTACT BIO CLEAN.

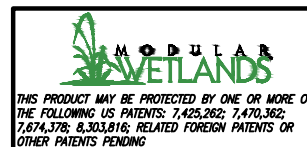

PROPRIETARY AND CONFIDENTIAL:  
THE INFORMATION CONTAINED IN THIS DOCUMENT IS THE SOLE PROPERTY OF FORTERRA AND ITS COMPANIES. THIS DOCUMENT, IN OR ANY PART THEREOF, MAY BE USED, REPRODUCED OR MODIFIED IN ANY MANNER WITH OUT THE WRITTEN CONSENT OF FORTERRA.



TREATMENT FLOW (CFS)	0.177
MAXIMUM TREATMENT CAPACITY (CFS)	0.177
OPERATING HEAD (FT)	2.9
PRETREATMENT LOADING RATE (GPM/SF)	1.6
WETLAND MEDIA LOADING RATE (GPM/SF)	1.0

**MWS-L-4-17-4'-3"-V**  
**STORMWATER BIOFILTRATION SYSTEM**  
**STANDARD DETAIL**



SITE SPECIFIC DATA			
PROJECT NUMBER	9931		
PROJECT NAME	DANA POINT HARBOR REVITALIZATION - COMMERCIAL CORE AREA		
PROJECT LOCATION	DANA POINT, CA		
STRUCTURE ID	BMP 16		
TREATMENT REQUIRED			
VOLUME BASED (CF)	FLOW BASED (CFS)		
N/A	0.129		
TREATMENT HGL AVAILABLE (FT)	N/K		
PEAK BYPASS REQUIRED (CFS) - IF APPLICABLE	0.98		
PIPE DATA	I.E.	MATERIAL	DIAMETER
INLET PIPE 1	10.63	HDPE	8"
OUTLET PIPE	9.88	HDPE	12"
	PRETREATMENT	BIOFILTRATION	DISCHARGE
RIM ELEVATION	14.38	14.38	14.38
SURFACE LOAD	PEDESTRIAN	N/A	PEDESTRIAN
FRAME & COVER	30" X 48"	OPEN PLANTER	N/A
WETLAND MEDIA VOLUME (CY)	3.45		
ORIFICE SIZE (DIA. INCHES)	Ø1.67"		
NOTES: PRELIMINARY NOT FOR CONSTRUCTION.			

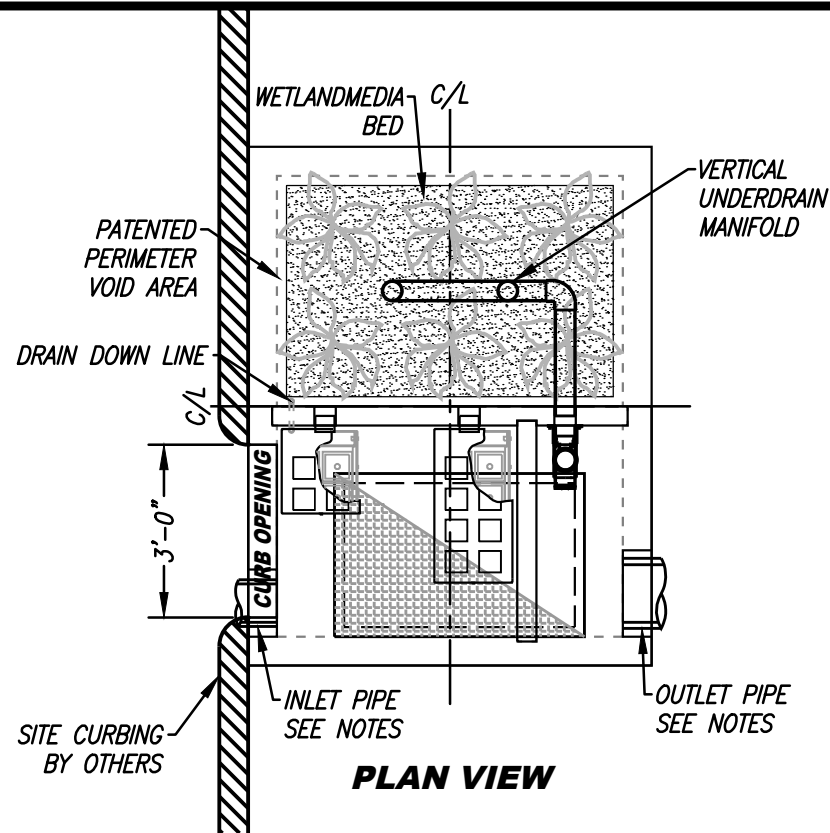

**PLAN VIEW**

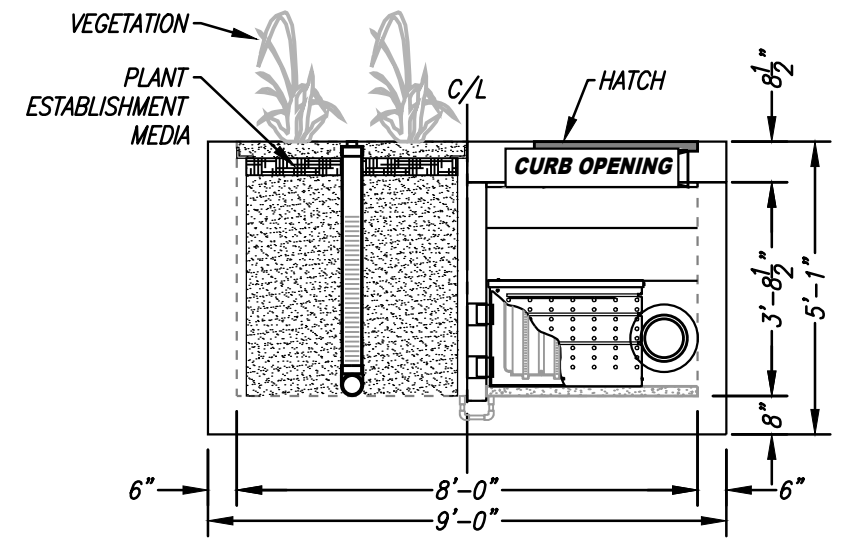

**LEFT END VIEW**

**LOW INFLOW PIPE DISCLOSURE:**

IT IS RECOMMENDED THAT A SUFFICIENT VARIATION IN ELEVATION BETWEEN THE INLET AND OUTLET BE PROVIDED TO ALLOW FOR ACCUMULATION OF SEDIMENT IN THE PRE-TREATMENT CHAMBER. FAILURE TO DO SO MAY RESULT IN BLOCKAGE AT INFLOW POINT(S) WHICH MAY CAUSE UPSTREAM FLOODING.

**INSTALLATION NOTES**

- CONTRACTOR TO PROVIDE ALL LABOR, EQUIPMENT, MATERIALS AND INCIDENTALS REQUIRED TO OFFLOAD AND INSTALL THE SYSTEM AND APPURTENANCES IN ACCORDANCE WITH THIS DRAWING AND THE MANUFACTURERS' SPECIFICATIONS, UNLESS OTHERWISE STATED IN MANUFACTURER'S CONTRACT.
- UNIT MUST BE INSTALLED ON LEVEL BASE. MANUFACTURER RECOMMENDS A MINIMUM 6" LEVEL ROCK BASE UNLESS SPECIFIED BY THE PROJECT ENGINEER. CONTRACTOR IS RESPONSIBLE FOR VERIFYING PROJECT ENGINEER'S RECOMMENDED BASE SPECIFICATIONS.
- CONTRACTOR TO SUPPLY AND INSTALL ALL EXTERNAL CONNECTING PIPES. ALL PIPES MUST BE FLUSH WITH INSIDE SURFACE OF CONCRETE (PIPES CANNOT INTRUDE BEYOND FLUSH). INVERT OF OUTFLOW PIPE MUST BE FLUSH WITH DISCHARGE CHAMBER FLOOR. ALL PIPES SHALL BE SEALED WATERTIGHT PER MANUFACTURER'S STANDARD CONNECTION DETAIL.
- CONTRACTOR RESPONSIBLE FOR INSTALLATION OF ALL PIPES, RISERS, MANHOLES, AND HATCHES. CONTRACTOR TO GROUT ALL MANHOLES AND HATCHES TO MATCH FINISHED SURFACE UNLESS SPECIFIED OTHERWISE.
- VEGETATION SUPPLIED AND INSTALLED BY OTHERS. ALL UNITS WITH VEGETATION MUST HAVE DRIP OR SPRAY IRRIGATION SUPPLIED AND INSTALLED BY OTHERS.
- CONTRACTOR RESPONSIBLE FOR CONTACTING BIO CLEAN FOR ACTIVATION OF UNIT. MANUFACTURER'S WARRANTY IS VOID WITHOUT PROPER ACTIVATION BY A BIO CLEAN REPRESENTATIVE.

**GENERAL NOTES**

- MANUFACTURER TO PROVIDE ALL MATERIALS UNLESS OTHERWISE NOTED.
- ALL DIMENSIONS, ELEVATIONS, SPECIFICATIONS AND CAPACITIES ARE SUBJECT TO CHANGE. FOR PROJECT SPECIFIC DRAWINGS DETAILING EXACT DIMENSIONS, WEIGHTS AND ACCESSORIES PLEASE CONTACT BIO CLEAN.

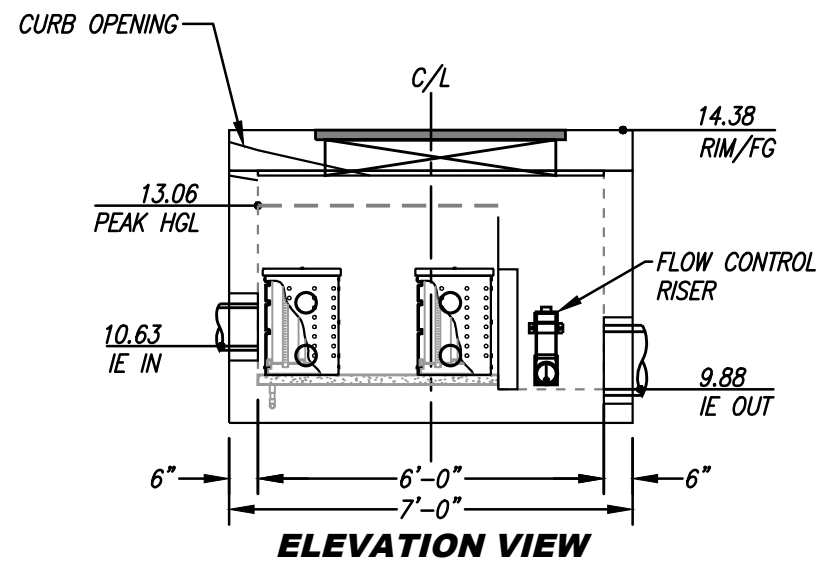

**ELEVATION VIEW**

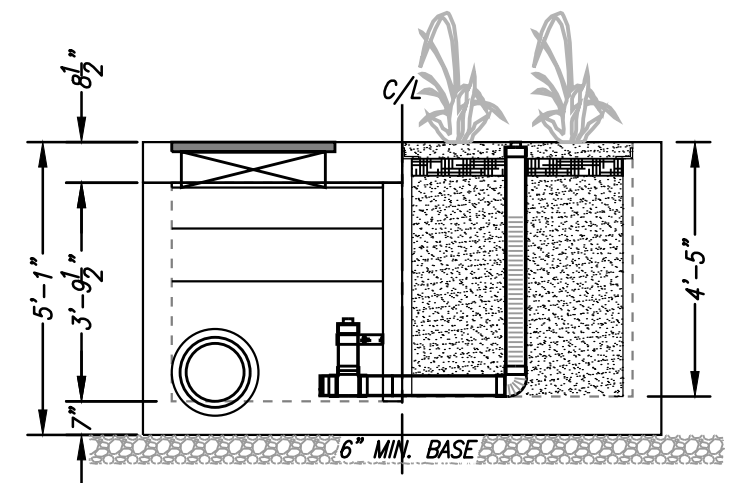

**RIGHT END VIEW**

**INTERNAL BYPASS DISCLOSURE:**

THE DESIGN AND CAPACITY OF THE PEAK CONVEYANCE METHOD TO BE REVIEWED AND APPROVED BY THE ENGINEER OF RECORD. HGL(S) AT PEAK FLOW SHALL BE ASSESSED TO ENSURE NO UPSTREAM FLOODING. PEAK HGL AND BYPASS CAPACITY SHOWN ON DRAWING ARE USED FOR GUIDANCE ONLY.

TREATMENT FLOW (CFS)	0.129
MAXIMUM TREATMENT CAPACITY (CFS)	0.129
OPERATING HEAD (FT)	3.0
PRETREATMENT LOADING RATE (GPM/SF)	1.5
WETLAND MEDIA LOADING RATE (GPM/SF)	1.0

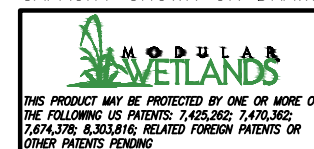

PROPRIETARY AND CONFIDENTIAL:  
THE INFORMATION CONTAINED IN THIS DOCUMENT IS THE SOLE PROPERTY OF FORTERRA AND ITS COMPANIES. THIS DOCUMENT, IN OR ANY PART THEREOF, MAY BE USED, REPRODUCED OR MODIFIED IN ANY MANNER WITH OUT THE WRITTEN CONSENT OF FORTERRA.



**MWS-L-6-8-4'-5''-C**  
**STORMWATER BIOFILTRATION SYSTEM**  
**STANDARD DETAIL**



# **Attachment G: Geotechnical Information**



## Memorandum

**To:** Mr. Bryon Ward  
President

**Date:** February 22, 2021

**Company:** Dana Point Harbor Partners, LLC  
c/o Burnham-Ward Properties

**GMU Project:** 17-206-02

**From:** Nadim Sunna, MS, PE, GE, Senior Engineer  
Gregory P. Silver, MS, PE, GE, President / Principal Geotechnical Engineer

**Subject:** **Preliminary Site Improvements Geotechnical Design Recommendations** –  
Dana Point Harbor Revitalization, Commercial Component, City of Dana Point

### RECOMMENDATIONS

- **Corrective Grading**

- Buildings 1, 6-12 Pads (Existing Grade Treatment)
  - The subgrade within the proposed building pad envelope locations should be excavated to a depth of 2 feet below the existing grade prior to raising of the grade. The excavation should extend laterally a minimum of 2 feet outside the edge of the building envelope.
  - The bottom of the over-excavation should then be scarified to a depth of at least 6 inches, moisture conditioned to least 2% above optimum moisture content, and recompacted to at least 92% relative compaction.
  - Following the approval of the over-excavation bottom by a representative of GMU, the onsite material may be used as fill material to achieve the planned subgrade elevation.
  - The fill material should then be placed in 6- to- 8-inch-thick lifts, moisture conditioned to at least 2% above optimum moisture content, and compacted to achieve 92% relative compaction.
- Buildings 1, 6-12 Pads (Load Transfer Platform)
  - The Load Transfer Platform (LTP) consisting of soil-cement mixture should be placed over the properly recompacted subgrade.
  - The minimum thickness of the LTP should be 3 feet and should extend to the edge of the building envelope.
  - A mix design should be performed to evaluate the required amount of cement for the section to achieve a 28-day unconfined compressive strength of 200 psi.

## MEMORANDUM

Mr. Bryon Ward, **DANA POINT HARBOR PARTNERS, LLC**, c/o Burnham-Ward Properties

*Preliminary Site Improvements Geotechnical Design Recommendations -*

*Dana Point Harbor Revitalization: Commercial Component*

- Based on the soil types encountered during our subsurface investigation, we anticipate that 6 percent cement can be used for budgeting purposes.
- Final mix design and cement content should be provided by the contractor prior to performing the work and should be reviewed by GMU.
- The cement should be dry mixed using a pulverizer. Homogenous mixing of the cement is crucial and requires proper equipment to achieve.
- Following dry mixing, perform a second mixing process with the introduction of water to hydrate the cement, if additional moisture is needed. The moisture content of the mixture must be approximately 1 to 3 percent above optimum moisture content. From the time initial application of water occurs, the material should be fully mixed (dry and wet) and compacted within 2.5 hours or less.
- Compaction of the final mixed/treated subgrade section should be performed using a large sheepsfoot compactor. The cement-treated section should be compacted to at least 92 percent of the maximum dry density as determined by ASTM D 1557.
- The surface of the treated material is wetted at least three times daily (possibly more depending on weather) to maintain and moist surface condition and promote hydration of the cement.
- For at least 24 hours, heavy traffic on the surface after completion of compaction should be minimized to the maximum extent possible and heavy construction equipment traffic should be completely avoided to prevent breakdown of the treated material prior to the curing process being completed. After 24 hours, the surface can be proof-rolled and checked for yielding under heavy rubber-tire vehicle loads (such as a fully-loaded water truck). If the surface indicates signs of yielding or instability, an additional 24 hours of cure time should be implemented while again minimizing heavy traffic loading.
- Vehicular Pavement
  - The subgrade within the proposed vehicular pavement areas should be excavated to a depth of 2 feet below the existing grade prior to raising of the grade.

## MEMORANDUM

Mr. Bryon Ward, **DANA POINT HARBOR PARTNERS, LLC**, c/o Burnham-Ward Properties

*Preliminary Site Improvements Geotechnical Design Recommendations -*

*Dana Point Harbor Revitalization: Commercial Component*

- The bottom of the over-excavation should then be scarified to a depth of at least 6 inches, moisture conditioned to least 2% above optimum moisture content, and recompacted to at least 92% relative compaction.
  - Following the approval of the over-excavation bottom by a representative of GMU, the onsite material may be used as fill material to achieve the planned subgrade elevation.
  - The fill material should then be placed in 6- to 8-inch-thick lifts, moisture conditioned to at least 2% above optimum moisture content, and compacted to achieve 92% relative compaction.
- Flatwork/Hardscape/Pedestrian Pavers
- The subgrade within the proposed flatwork/hardscape/pedestrian paver areas should be excavated to a depth of 1 foot below the existing grade prior to raising of the grade.
  - The bottom of the over-excavation should then be scarified to a depth of at least 6 inches, moisture conditioned to least 2% above optimum moisture content, and recompacted to at least 92% relative compaction.
  - Following the approval of the over-excavation bottom by a representative of GMU, the onsite material may be used as fill material to achieve the planned subgrade elevation.
  - The fill material should then be placed in 6- to 8-inch-thick lifts, moisture conditioned to at least 2% above optimum moisture content, and compacted to achieve 92% relative compaction.
- Appurtenant Structures / Site Retaining Walls
- The appurtenant structures / site retaining walls should be over-excavated to a depth of at least 24 inches below the bottom of the foundations.
  - The bottom of the over-excavation should then be scarified to a depth of at least 6 inches, moisture conditioned to least 2% above optimum moisture content, and recompacted to at least 92% relative compaction.
  - Following the approval of the over-excavation bottom by a representative of GMU, the onsite material may be used as fill material to achieve the planned foundation bottom elevation.
  - The fill material should be placed in 6- to 8-inch-thick lifts, moisture conditioned to 2% above optimum moisture content, and compacted to achieve 92% relative compaction.

## MEMORANDUM

Mr. Bryon Ward, **DANA POINT HARBOR PARTNERS, LLC**, c/o Burnham-Ward Properties

*Preliminary Site Improvements Geotechnical Design Recommendations -*

*Dana Point Harbor Revitalization: Commercial Component*

- **Volume Change**

- In order to aid in planning for the anticipated grading, we estimate that the change in volume of on-site disturbed surficial fills that are excavated and placed as new compacted fill at an average relative compaction of 92% will result in volume losses ranging from approximately 5 to 10%. For rough planning purposes only, an average volume loss of 7.5% may be assumed.

- **Dewatering**

- Groundwater is not anticipated to be encountered during corrective grading. Consequently, dewatering is not anticipated.
- Groundwater should be anticipated during installation of deeper utilities. Groundwater should be pumped from utility trenches prior to placement of slurry.
- Final evaluation as to the need for dewatering should be made by the contractor immediately prior to grading.

- **Utility Trench Design and Backfill Considerations**

- Utility Backfill (Above Groundwater)

- Pipe bedding should extend at least 6 inches below the pipes to at least 12 inches above the crown of the pipes.
- Pile bedding should consist of either clean sand with an SE of at least 30, or crushed rock.
  - If crushed rock is used, it should consist of 3/4 inch crushed rock.
  - If crushed rock is used, it should be capped with filter fabric (Mirafi 140N or equivalent) to prevent migration of fines into the rock.
- Trench backfill zone may consist of the onsite soil, moisture conditioned to 2% above optimum moisture content and compacted to achieve 92% relative compaction.
  - Jetting is not permitted.
  - No broken rock or broken concrete greater than 6 inches in diameter should be utilized in the trench backfill.

- Utility Backfill (Below Groundwater)

- Utilities that are planned below the groundwater elevation should be backfilled with 2 sack sand-cement slurry to at least 6 inches above the encountered groundwater.
- Backfill zone above the groundwater may consist of onsite soil or 2 sack slurry.

**MEMORANDUM**

Mr. Bryon Ward, **DANA POINT HARBOR PARTNERS, LLC**, c/o Burnham-Ward Properties

*Preliminary Site Improvements Geotechnical Design Recommendations -*

*Dana Point Harbor Revitalization: Commercial Component*

- If onsite soil is used, it should be placed after the slurry has been allowed to sit and cure for a minimum of 8 hours.
- Onsite soil should be moisture conditioned to 2% above optimum moisture content and compacted to at least 92% relative compaction.

- **Pavement Design Recommendations**

- Asphalt Concrete

- Based on an R-value of 10, we have developed the following pavement structural sections:

Location	R-Value	Traffic Index	Asphalt Concrete (in.)	Aggregate Base (in.)
Car Parking Stalls	10	4.0	4.0	4.0
Drive Aisles	10	5.5	4.0	9.5

- Crushed miscellaneous base (CMB) or crushed aggregate base (CAB) materials meeting the minimum County of Orange requirements.
      - Asphalt concrete (AC) materials of a type meeting the minimum County of Orange requirements.
      - The subgrade soils should be moisture conditioned to a minimum 2% above the optimum moisture content to a depth of at least 6 inches and compacted to at least 92% relative compaction (per ASTM 1557).
      - The CMB or CAB and AC should be compacted to at least 95% relative compaction (per ASTM 1557).

- Portland Cement Concrete

- Driveways, vehicular drives, and appurtenant concrete paving, such as trash receptacle bays, will require Portland cement concrete (PCC) pavement.
    - Assuming a T.I. of 6 to 7, a design section of 8 inches of PCC over 6 inches AB should be adequate.
    - PCC vehicular pavement should be designed in accordance with the County of Orange standards.

- **Recycled AC Material**

- The use of stockpiled in-place recycled AC and crushed miscellaneous base (CMB) for new engineered fill subgrade, and CMB outside building and landscaped areas and under new asphalt concrete pavement and hardscape is acceptable from a geotechnical standpoint.

**MEMORANDUM**

Mr. Bryon Ward, **DANA POINT HARBOR PARTNERS, LLC, c/o Burnham-Ward Properties**

*Preliminary Site Improvements Geotechnical Design Recommendations -*

*Dana Point Harbor Revitalization: Commercial Component*

- The recycled AC will require GMU to conduct conformance laboratory testing on representative samples of the pulverized recycled asphalt pavement to confirm that the samples meet the 2019 Greenbook Section 200-2.4 standards for Crushed Miscellaneous Base (CMB).
- GMU recommends that this recycled CMB may be used as engineered fill for exterior subgrade structural support of new asphalt concrete and hardscape improvements outside of the building envelopes.
- The recycled concrete pavement is not to be used as compacted fill for support under any of the building areas or in the planters on the subject site.

• **Flatwork Design Recommendations**

<b>Description</b>	<b>Subgrade Preparation <sup>(1)</sup></b>	<b>Minimum Concrete Thickness</b>	<b>Reinforcement <sup>(2)</sup></b>	<b>Expansion Joint Spacing <sup>(3)</sup> (Minimum)</b>	<b>Concrete <sup>(4)</sup></b>
Concrete Paving (Sidewalk) <sup>(5)</sup>	1) 2% over optimum to 8-inches at 92% relative compaction 2) *4-inches of CAB or CMB compacted to a minimum of 95% relative compaction	4-inches	No. 3 bars @ 18" o.c. and dowel into existing flatwork, doorways and, curbs using No. 3 bars @ 18"o.c	6-foot x 6-foot using 9-inch speed dowels with No. 3 bars @ 18" o.c.	Type II/V 3,250 psi min.
Concrete Paving (Patio) <sup>(5)</sup>	1) 2% over optimum to 8-inches at 92% relative compaction 2) *4-inches of CAB or CMB compacted to a minimum of 95% relative compaction	5-inches	No. 3 bars @ 18" o.c. and dowel into existing flatwork, doorways, and curbs existing paving using No. 3 bars @ 18"o.c	10-foot x 10-foot using 9-inch speed dowels with No. 3 bars @ 18" o.c.	Type II/V 3,250 psi min.
Concrete Interlocking Pavers underlain by 1" of sand (non-vehicular) <sup>(6)</sup>	1) 2% over optimum to 8-inches at 92% relative compaction; 2) 4-inches of CAB or CMB compacted to a minimum of 95% relative compaction or concrete sub slab may be used in lieu of base section (see adjacent column).	4-inch concrete sub slab if 4-inch CMB base section not used	1) Slab – No. 3 bars @ 18" o.c. and dowel into existing flatwork, doorways and, curbs using No. 3 bars @ 18"o.c; 2) where adjacent to structures, curbs, etc. and at cold joints - use dowels: No. 3 @ 18" o.c	10-foot x 10-foot using 9-inch speed dowels with No. 3 bars @ 18" o.c.	Type II/V 3,250 psi min.

**MEMORANDUM**

Mr. Bryon Ward, **DANA POINT HARBOR PARTNERS, LLC**, c/o Burnham-Ward Properties  
*Preliminary Site Improvements Geotechnical Design Recommendations -  
 Dana Point Harbor Revitalization: Commercial Component*

Concrete Interlocking Pavers underlain by 1" of sand (vehicular) <sup>(6)</sup> <sup>(7)</sup>	1) 2% over optimum to 8-inches at 92% relative compaction; 2) 12 inches of CAB or CMB compacted to a minimum of 95% relative compaction over Mirafi 600X or equivalent fabric or concrete sub slab may be used in lieu of base/fabric section (see adjacent column)	6-inch concrete sub slab if 12-inch CMB base section not used	1) Slab – No. 3 bars @ 18" o.c. and dowel into existing flatwork, doorways and, curbs using No. 3 bars @ 18" o.c.; 2) where adjacent to curbs and at cold joints - use dowels: No. 3 bars @ 18" o.c.	10-foot x 10-foot using 9-inch speed dowels with No. 3 bars @ 18" o.c.	Type II/V 3,250 pi min.
--	---	---	--	--	----------------------------

**\*Recommended 4" of AB/CMB under pedestrian concrete pavement to be confirmed by project design team. As alternate to AB/CMB, cement treated spoils may be used under pedestrian flatwork areas.**

- (1) *The moisture content and compaction of the subgrade must be verified by the geotechnical consultant prior to base placement.*
- (2) *Reinforcement to be placed in the middle of the recommended concrete section.*
- (3) *Control Joints: Suggested spacing of sidewalk areas at 6-foot square and patio areas at 10-foot square.*
- (4) *Final concrete mix design to be supplied by others.*
- (5) *Where new trees or large shrubs are to be located in close proximity of new concrete flatwork, rigid moisture/root barriers should be placed around the perimeter of the flatwork to least 2 feet deep in order to offer protection to the adjacent flatwork against potential root and moisture damage. Existing mature trees near flatwork areas should also incorporate a rigid moisture/root barrier placed to at least 2 feet below the top of the flatwork.*
- (6) *The minimum thickness of pavers should be 2 3/8" for pedestrian application and 3 1/8" for vehicular application, and should be installed per minimum manufacturer's recommendations, including min. 1" sand bedding. It is highly recommended that if vehicular pavers are to be constructed, they should maintain an aspect ratio of 3 to 1 or less (where the length of the paver is 3 times the thickness of the paver or less) in order to minimize edge cracking.*
- (7) *Concrete bands adjacent to the vehicular interlocking pavers should consist of a design section of 8 inches of PCC over at least 6 inches of AB or equivalent, moisture conditioned to at least optimum moisture, and compacted to at least 95% relative compaction.*

**General Note:** *Minor deviations to the above recommendations may be required at the discretion of the soils engineer or his representative.*

• **Root Barriers**

- *Where new trees or large shrubs are to be located in close proximity to new concrete flatwork, rigid moisture/root barriers should be placed around the perimeter of the flatwork to at least 12 inches in depth in order to offer protection to the adjacent flatwork against potential root and moisture damage.*
- *Flatwork areas with existing mature trees should also incorporate a rigid moisture/root barrier placed at least 2 feet in depth below the top of the flatwork.*